

MINI

*D.H. Carpenter
171. Regent Gae
North Shields
N/S. 546903*

**SALOON, COUNTRYMAN and TRAVELLER
CLUBMAN, ESTATE and 1275 GT
VAN, PICK-UP and MOKE
COOPER and COOPER 'S'**

WORKSHOP MANUAL

Part No. AKD 4935 (6th Edition)



British Leyland (Austin-Morris) Limited
Service division, Cowley, Oxford, England

INTRODUCTION

DESCRIPTION

This Manual is intended to assist the skilled mechanic in carrying out repairs and replacements in a minimum time.

The information at the front of the book includes general data, tightening torque figures and engine tuning data. Recommended lubricants and Service tools are featured at the end of the Manual.

References to left- or right-hand side in this Manual are made when viewing the car from the rear.

MANUAL ARRANGEMENT

The Manual is divided into Sections, and each Section carries a reference letter that identifies the Section with an assembly or a major component.

Each Section is prefixed with a contents page and is sub-divided numerically. The pages and illustrations are numbered consecutively within each Section and the Section title and letter are shown at the top of each page.

Sections having the suffix 'a' contain supplementary information dealing with the Mini fitted with Automatic transmission.

Sections having the suffix 'b' contain supplementary information applicable to the Mini range, i.e. 850, 1000, Clubman, 1275 GT, and the Cooper 'S' Mk. III. These vehicles have **NEGATIVE** earth electrical systems.

REPAIRS AND REPLACEMENTS

When service parts are required it is essential that only genuine British Leyland (Austin-Morris) or Unipart replacements are used.

Attention is particularly drawn to the following points concerning repairs and the fitting of replacement parts and accessories:

Safety features embodied in the car may be impaired if other than genuine parts are fitted.

In certain territories, legislation prohibits the fitting of parts not to the vehicle manufacturer's specification.

Torque wrench setting figures given in the Manual must be strictly adhered to.

Locking devices, where specified, must be fitted. If the efficiency of a locking device is impaired during removal it must be renewed.

Owners purchasing accessories while travelling abroad should ensure that the accessory and its fitted location on the car conform to mandatory requirements existing in their country of origin.

The car warranty may be invalidated by the fitting of other than genuine British Leyland parts.

All British Leyland (Austin-Morris) or Unipart replacements have the full backing of the factory warranty.

British Leyland Distributors and Dealers are obliged to supply only genuine service parts.



© British Leyland (Austin-Morris) Limited, 1971

All rights reserved. No part of this publication may be reproduced, stored in a retrieval system or transmitted, in any form, electronic, mechanical, photocopying, recording or other means without prior written permission of British Leyland (Austin-Morris) Limited Service Division.

INTRODUCTION

SPECIFICATION

Purchasers are advised that the specification details set out in this Manual apply to a range of vehicles and not to any particular vehicle. For the specification of any particular vehicle purchasers should consult their Distributor or Dealer.

The manufacturers reserve the right to vary their specifications with or without notice, and at such times and in such manner as they think fit. Major as well as minor changes may be involved in accordance with the manufacturer's policy of constant product improvement.

Whilst every effort is made to ensure the accuracy of the particulars contained in this Manual, neither the manufacturer nor the Distributor or Dealer, by whom this Manual is supplied, shall in any circumstances be held liable for any inaccuracy or the consequences thereof.

IMPORTANT



On cars fitted with exhaust emission control equipment (Exhaust Port Air Injection) service operations and adjustments showing this symbol must be followed by an exhaust emission check.

Servicing and adjusting engine emission control equipment must be carried out in accordance with the instructions given in **Workshop Manual Supplement AKD 4957**.

Self-locking Nuts

Deformed thread stiffnuts must not be re-used where the lacquer coating (SMT65) is affected in any way, and they must not be degreased in any circumstances. New cuts must always be used if their clamping torque has been lowered.

IMPORTANT. Insert-type stiffnuts must be used on the front suspension tie rods and front end to frame fixings. Deformed thread stiffnuts must not be used in these positions even if originally fitted. New insert-type stiffnuts must always be used on drive shafts.

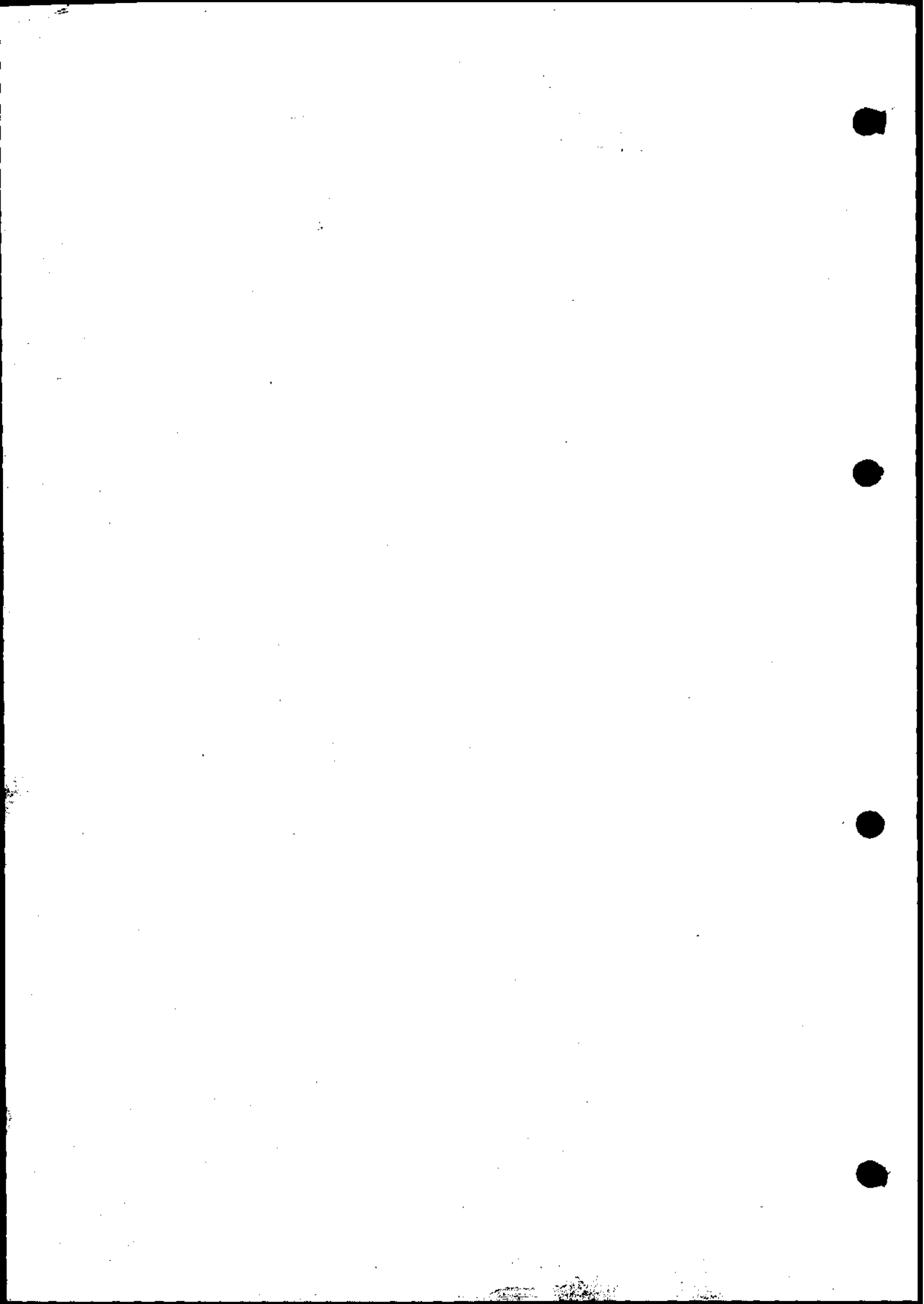

CONTENTS

| | <i>Pages</i> |
|--------------------------------|-------------------|
| Introduction | 2 |
| Data Contents | 4 |
| General Data | General Data 1-33 |
| Tuning Data | Tuning Data 1-10 |
| <i>Sections</i> | |
| Engine | A, Aa |
| Ignition | B, Ba |
| Cooling System | C |
| Fuel System | D, Da, Db |
| Clutch | E |
| Transmission | F, Fa |
| Drive Shafts | G |
| Rear Suspension | H |
| Steering | J |
| Front Suspension | K |
| Hydraulic Dampers | L |
| Braking System | M, Mb |
| Electrical | N, Nb |
| Body | R, Rb |
| Service Tools | S |
| Recommended Lubricants | End of Manual |

DATA CONTENTS

General Data

| | |
|--|----------|
| Mini Mk. I and II (848 c.c.) and Mk. II (998 c.c.) | GD.1-9 |
| Mini-Cooper (997 c.c. and 998 c.c.) | GD.10-13 |
| Mini-Cooper 'S' Mk. I (970 c.c., 1071 c.c., and 1275 c.c.) and Mk. II and III (1275 c.c.) .. | GD.14-18 |
| Mini Automatic (848 c.c. and 998 c.c.) | GD.19-20 |
| Mini 850/1000 Saloon, Van, and Pick-up | GD.21-23 |
| Mini Clubman and Estate | GD.24-26 |
| Mini 1275 GT | GD.27-33 |

Tuning Data

| | |
|---|-------------------|
| Mini Mk. I (848 c.c.) | Tuning Data TD.1 |
| Mini Mk. II (998 c.c.) | Tuning Data TD.2 |
| Mini Automatic (848 c.c.) | Tuning Data TD.3 |
| Mini Automatic (998 c.c.) | Tuning Data TD.4 |
| Mini-Cooper (997 c.c.) | Tuning Data TD.5 |
| Mini-Cooper (998 c.c.) | Tuning Data TD.6 |
| Mini-Cooper 'S' (970 c.c. and 1071 c.c.) | Tuning Data TD.7 |
| Mini-Cooper 'S' Mk. I, II and III (1275 c.c.) | Tuning Data TD.8 |
| Mini Clubman | Tuning Data TD.9 |
| Mini 1275 GT | Tuning Data TD.10 |

GENERAL DATA

MINI MK. I & II (848 c.c.) & MK. II (998 c.c.)

| | (848 c.c.) | (998 c.c.) |
|-----------------------------|---|--|
| ENGINE | | |
| Type | 8MB. | 99H. |
| Number of cylinders | 4. | 4. |
| Bore | 2.478 in. (62.94 mm.). | 2.543 in. (64.588 mm.). |
| Stroke | 2.687 in. (68.26 mm.). | 3.00 in. (76.2 mm.). |
| Capacity | 51.7 cu. in. (848 c.c.). | 60.96 cu. in. (998 c.c.). |
| Firing order | 1, 3, 4, 2. | 1, 3, 4, 2. |
| Valve operation | Overhead by push-rod. | Overhead by push-rod. |
| B.M.E.P. | 128 lb./sq. in. (9 kg./cm. ²) at 2,900 r.p.m. | 130 lb./sq. in. (9.14 kg./cm. ²) at 2,700 r.p.m. |
| Torque | 44 lb. ft. (6.08 kg. m.) at 2,900 r.p.m. | 52 lb. ft. (7.28 kg. m.) at 2,700 r.p.m. |
| Oversize bores: 1st | +0.010 in. (.254 mm.). | +0.010 in. (.254 mm.). |
| 2nd | +0.020 in. (.508 mm.). | +0.020 in. (.508 mm.). |

CRANKSHAFT

| | |
|---|--|
| Main journal diameter | 1.7505 to 1.751 in. (44.46 to 44.47 mm.). |
| Minimum regrind diameter | 1.7105 in. (43.45 mm.). |
| Crankpin journal diameter | 1.6254 to 1.6259 in. (41.28 to 41.29 mm.). |
| Crankpin minimum regrind diameter | 1.5854 in. (40.27 mm.). |

Main bearings

| | |
|---------------------------|---|
| Number and type | 3 shell type. |
| Material | Steel-backed white metal. Steel-backed copper-lead; thin wall. |
| Running clearance | .0005 to .002 in. (.013 to .051 mm.). .001 to .0027 in. (.025 to .069 mm.). |
| Length | 1.187 in. (30.16 mm.). |
| End-clearance | .0002 to .003 in. (.051 to .076 mm.). |
| End-thrust | Taken on centre main bearing. |

CONNECTING RODS

| | |
|--------------------------------|------------------------|
| Length between centres | 5.75 in. (14.605 cm.). |
|--------------------------------|------------------------|

Big-end bearings

| | |
|---------------------------------------|---------------------------------------|
| Bearing side-clearance | .008 to .012 in. (.203 to .305 mm.). |
| Bearing diametrical clearance | .001 to .0025 in. (.025 to .063 mm.). |
| Bearing length | .875 in. (22.22 mm.). |

PISTONS

| | |
|-------------------------------------|--|
| Type | Split skirt. Solid skirt. |
| Clearances: Bottom of skirt | .0006 to .0012 in. (.015 to .030 mm.). .0005 to .0011 in. (.013 to .028 mm.). |
| Top of skirt | .0026 to .0032 in. (.066 to .081 mm.). |
| Oversizes | +0.010 in., +0.020 in., +0.030 in., +0.040 in. +0.010 in., +0.020 in. (.254 mm., .508 mm., .762 mm., 1.016 mm.). (.254 mm., .508 mm.). |

PISTON RINGS

| | | |
|-----------------------------|--|--|
| Compression: Plain | Top ring. | Top ring, chrome-faced. |
| Tapered | Second and third rings. | Second and third rings. |
| Width | .069 to .070 in. (1.75 to 1.78 mm.). | .0620 to .0625 in. (1.574 to 1.588 mm.). |
| Thickness | .095 to .101 in. (2.41 to 2.56 mm.). | .106 to .112 in. (2.692 to 2.835 mm.). |
| Fitted gap | .007 to .012 in. (.178 to .305 mm.). | |
| Clearance in groove | .0015 to .0035 in. (.038 to .089 mm.). | |

GENERAL DATA

MINI MK. I & II (848 c.c.) & MK. II (998 c.c.)—continued

| | (848 c.c.) | (988 c.c.) |
|-----------------------------|------------|--|
| Oil control type | | Slotted scraper. |
| Width | | .124 to .125 in. (3.15 to 3.175 mm.). |
| Thickness | | .095 to .101 in. (2.41 to 2.56 mm.). |
| Fitted gap | | .007 to .012 in. (.178 to .305 mm.). |
| Clearance in groove | | .0015 to .0035 in. (.038 to .089 mm.). |

GUIDGEON PIN

| | | |
|--------------------------|------------------------|---------------------------------------|
| Type | Clamped in little-end. | Fully floating, with circlip location |
| Fit in piston | Hand push-fit. | Hand push-fit. |
| Diameter (outer) | | .624 in. (15.86 mm.). |

VALVES AND VALVE GEAR

Valves

| | |
|--|--|
| Seat angle: Inlet | 45°. |
| Exhaust | 45°. |
| Head diameter: Inlet | 1.093 to 1.098 in. (27.76 to 27.89 mm.). |
| Exhaust | 1.000 to 1.005 in. (25.40 to 25.53 mm.). |
| Stem diameter: Inlet | .2793 to .2798 in. (7.096 to 7.109 mm.). |
| Exhaust | .2788 to .2793 in. (7.081 to 7.096 mm.). |
| Valve lift | .285 in. (7.24 mm.). |
| Valve stem to guide clearance: Inlet | .0015 to .0025 in. (.038 to .064 mm.). |
| Exhaust | .002 to .003 in. (.051 to .076 mm.). |
| Valve rocker clearance: Running | .012 in. (.305 mm.) (cold). |
| Timing | .019 in. (.48 mm.). |
| Timing markings | Dimples on timing wheels, marks on flywheel. |
| Chain pitch and number of pitches | $\frac{3}{8}$ in. (9.525 mm.). 52. |
| Inlet valve: Opens | 5° B.T.D.C. |
| Closes | 45° A.B.D.C. |
| Exhaust valve: Opens | 40° B.B.D.C. |
| Closes | 10° A.T.D.C. |
| Valve rocker bush bore (reamed) | .5630 to .5635 in. (14.30 to 14.312 mm.). |

VALVE GUIDES

| | |
|--|--|
| Length: Inlet and exhaust | 1.687 in. (42.86 mm.). |
| Diameter: Outside: Inlet and exhaust | .469 in. (11.91 mm.). |
| Inside: Inlet and exhaust | .2813 to .2818 in. (7.145 to 7.257 mm.). |

VALVE SPRINGS

| | |
|---|------------------------|
| Free length: Inlet and exhaust | 1.625 in. (41.27 mm.). |
| Number of working coils | 4 $\frac{1}{2}$. |
| Pressure: Inlet and exhaust: Valve open | 70 lb. (31.8 kg.). |
| Valve closed | 37.5 lb. (17.027 kg.). |

TAPPETS

| | |
|------------------|-----------------------|
| Diameter | .812 in. (20.64 mm.). |
| Length | 1.5 in. (38.10 mm.). |

GENERAL DATA

MINI MK. I & II (848 c.c.) & MK. II (998 c.c.)—*continued*

| | (848 c.c.) | (998 c.c.) |
|---|------------|--|
| CAMSHAFT | | |
| Journal diameters: Front | | 1.6655 to 1.666 in. (42.304 to 42.316 mm.). |
| Centre | | 1.62275 to 1.62325 in. (41.218 to 41.231 mm.). |
| Rear | | 1.3725 to 1.3735 in. (34.862 to 34.887 mm.). |
| End-float | | .003 to .007 in. (.076 to .178 mm.). |
| Bearings: Type: Front | | White-metal-lined, steel-backed. |
| Centre and rear | | Plain (running in block). |
| Inside diameter (reamed in position) | | 1.667 to 1.6675 in. (42.342 to 32.355 mm.). |
| Clearance: Front | | .001 to .002 in. (.025 to .051 mm.). |
| Centre and rear | | .00125 to .00275 in. (.0317 to .0698 mm.). |
| Bearings: number and type | | 3. Steel-backed white metal. |
| Inside diameter (reamed in position): Front | | 1.667 to 1.6675 in. (42.342 to 42.355 mm.). |
| Centre | | 1.6245 in. (41.261 to 41.287 mm.). |
| Rear | | 1.3748 to 1.3755 in. (34.914 to 34.937 mm.). |
| Running clearance | | .001 to .002 in. (.025 to .051 mm.). |

ENGINE LUBRICATION SYSTEM

| | | |
|--|--|--|
| Oil pump | | |
| Type | | Concentric or Hobourn-Eaton. |
| Relief pressure valve opens | | 60 lb./sq. in. (4.2 kg./cm. ²). |
| Relief valve spring: Free length | | 2 $\frac{3}{8}$ in. (72.63 mm.). |
| Fitted length | | 2 $\frac{1}{2}$ in. (54.77 mm.). |
| Oil filter | | |
| Type | | Full-flow. |
| Capacity | | 1 pint (1.2 U.S. pints, .57 litre). |
| Oil pressure | | |
| Normal running | | 60 lb./sq. in. (4.22 kg./cm. ²). |
| Idling (minimum) | | 15 lb./sq. in. (1.05 kg./cm. ²). |

COOLING SYSTEM

| | | |
|----------------------------|--|--|
| Type | | Pressurized radiator, thermo-siphon, pump- and fan-assisted. |
| Pressure cap | | 13 lb./sq. in. (.91 kg./cm. ²). |
| Thermostat setting | | 82° C. (180° F.). |
| Cold climates | | 88° C. (188° F.). |
| Hot climates | | 74° C. (165° F.). |

FUEL SYSTEM

Carburettor refer to 'TUNING DATA'.

Fuel pump

Make and type: Early saloons S.U. electric. PD.
 Later vehicles S.U. electric. SP.

S.U. electric. SP and AUF 201 type.

GENERAL DATA

MINI MK. I & II (848 c.c.) & MK. II (998 c.c.)— *continued*

| | (848 c.c.) | (998 c.c.) |
|------------------------------------|------------|---|
| Delivery rate: PD type | | 45 pints/hr. (25.5 litres/hr.). |
| SP and AUF 201 type | | 56 pints/hr. (32 litres/hr.). |
| Delivery pressure: PD type | | 2 to 3 lb./sq. in. (.14 to .21 kg./cm. ²). |
| SP and AUF 201 type | | 2½ to 3 lb./sq. in. (.17 to .21 kg./cm. ²). |

CLUTCH

BMC single dry plate

| | |
|--------------------------|---------------------|
| Diameter | 7½ in. (180.9 mm.). |
| Facing material | Wound yarn. |
| Pressure springs | 6. |
| Colour | Red spot. |
| Damper springs | Nil. |

Diaphragm-spring clutch

| | |
|------------------------------|--|
| Make | Borg and Beck. |
| Diameter | 7½ in. (180.9 mm.). |
| Facing material | Wound yarn. |
| Damper springs | Nil. |
| Diaphragm-spring colour code | Brown. Light green. |

TRANSMISSION

Gearbox

| | |
|----------------------------------|----------------------------------|
| Number of forward speeds | 4. |
| Synchromesh | Second, third, and fourth gears. |
| Ratios: Top | 1.0 : 1. |
| Third | 1.412 : 1. |
| Second | 2.172 : 1. |
| First | 3.627 : 1. |
| Reverse | 3.627 : 1. |
| Overall ratios: Top | 3.765 : 1. |
| Third | 5.317 : 1. |
| Second | 8.176 : 1. |
| First | 13.657 : 1. |
| Reverse | 13.657 : 1. |

Final drive

| | |
|-------------------------|---|
| Type | Helical gears and differential. |
| Ratio: Saloon | 3.765 : 1 (17/64). 3.44 : 1 (18/62). |
| Van and Pick-up | 3.76 : 1 (17/64). |

Gearbox

| | (From Engine No. 8AM-WE-H101) | (From Engine Nos. 99H-159-H101 and 99H-251-H101) |
|--|-------------------------------|--|
| Number of forward speeds | 4. | 4. |
| Synchromesh | All forward gears. | All forward gears. |
| Ratios: Top | 1.00 : 1. | 1.00 : 1. |
| Third | 1.43 : 1. | 1.43 : 1. |
| Second | 2.21 : 1. | 2.21 : 1. |
| First | 3.52 : 1. | 3.52 : 1. |
| Reverse | 3.54 : 1. | 3.54 : 1. |
| Overall ratios: Top | 3.76 : 1. | 3.44 : 1. |
| Third | 5.40 : 1. | 4.93 : 1. |
| Second | 8.32 : 1. | 7.63 : 1. |
| First | 13.25 : 1. | 12.13 : 1. |
| Reverse | 13.30 : 1. | 12.19 : 1. |
| Road speed at 1,000 r.p.m. in top gear | 15.2 m.p.h. (24.3 km.p.h.). | 16.2 m.p.h. (25.75 km.p.h.). |

GENERAL DATA

MINI MK. I & II (848 c.c.) & MK. II (998 c.c.)—*continued*

DRIVE SHAFTS

| | |
|--------------------------------|------------------------------------|
| Type | Solid shaft, reverse spline. |
| Make and type of joint | Hardy Spicer, hemispherical joint. |

STEERING

| | | |
|---|-----------------------------|--|
| Type | Rack and pinion. | |
| Steering-wheel turns—lock to lock | 2½. | |
| Steering-wheel diameter | 15¾ in. (40 cm.). | |
| Camber angle | 1° positive to 3° positive. | } with vehicle in an unladen condition. |
| Castor angle | 3° | |
| King pin (swivel hub) inclination | 9° 30' | |
| Toe-out | ½ in. (1.6 mm.) | |
| Lock angle: outer wheel at 20°, inner wheel | 23° | |

FRONT SUSPENSION

| | |
|--|--|
| Early models, 1959–1964 | Rubber cone spring. |
| Later models | Hydrolastic displacers. |
| Fluid capacity | 4 pints (5 U.S. pints, 2.27 litres). |
| Fluid pressure: Early models (unladen) | 263 lb./sq. in. (18.49 kg./cm. ²). |
| Later models (unladen) | 282 lb./sq. in. (19.74 kg./cm. ²). |

(Car Nos. given in Section H.10)

REAR SUSPENSION

| | |
|---|--|
| Type | Rubber cone spring. |
| Toe-in | ½ in. (3.18 mm.). |
| Camber | 1° positive. |
| Radius arm bushes (reamed bore) | .8125 to .8130 in. (20.63 to 20.65 mm.). |

HYDRAULIC DAMPERS (Rubber suspension only)

| | |
|------------------------------|---------------------|
| Type: Front and rear | Tubular telescopic. |
|------------------------------|---------------------|

BRAKES (Up to Chassis Nos. 296256 and 638878)

| | |
|--|---|
| Lockheed hydraulic | Single-leading shoe. |
| Drum size | 7 in. (17.8 cm.) diameter. |
| Lining dimensions: Front or rear | 6.75 in. × 1.25 in. (17.14 cm. × 3.17 cm.). |
| Lining area: Front or rear | 33.75 sq. in. (217.7 cm. ²). |
| Lining material | Don 202. |
| Master cylinder bore diameter | ¾ in. (19.05 mm.). |

Wheel cylinders

| | |
|---------------------------------------|--------------------|
| Cylinder bore diameter: Front | ⅞ in. (20.64 mm.). |
| Rear | ⅝ in. (15.87 mm.). |

GENERAL DATA

MINI MK. I & II (848 c.c.) & MK. II (998 c.c.)—*continued*

BRAKES (From Chassis Nos. 296257 and 638879)

| | |
|---------------------------------------|---|
| Lockheed hydraulic | Two-leading-shoe. |
| Lining dimensions | 6.75 × 1.5 in. (17.4 × 3.8 cm.). |
| Lining area per wheel: Front | 20.5 sq. in. (132.3 cm. ²). |
| Rear | 17.1 sq. in. (110.3 cm. ²). |
| Swept area per wheel: Front | 33 sq. in. (213 cm. ²). |
| Rear | 27.5 sq. in. (177.4 cm. ²). |
| Master cylinder bore diameter | |
| Lining material | Don 202. |
| Wheel cylinders | |
| Cylinder bore diameter: Front | $\frac{15}{16}$ in. (23.81 mm.). |
| Rear | $\frac{3}{4}$ in. (19.05 mm.). |

WHEELS

| | |
|-------------------------------|-------------|
| Type: ventilated disc | 3.50B × 10. |
|-------------------------------|-------------|

TYRES

| | |
|------------------------------------|--|
| Size: | |
| Standard | 5.20—10 tubeless. |
| Radial ply | 145—10 tubeless. |
| Pressures: | |
| Standard—normal conditions | Front 24 lb./sq. in. (1.7 kg./cm. ²). |
| Rear | 22 lb./sq. in. (1.55 kg./cm. ²). |
| fully loaded | Front and rear 24 lb./sq. in. (1.7 kg./cm. ²). |
| Radial ply, all conditions | Front 28 lb./sq. in. (1.97 kg./cm. ²). |
| Rear | 26 lb./sq. in. (1.83 kg./cm. ²). |

ELECTRICAL EQUIPMENT

| | |
|---|-----------------------------------|
| System | 12-volt, positive earth. |
| Charging system | Compensated voltage control. |
| Battery | Lucas BLT7A, BLTZ7A, BT7A, BTZ7A. |
| Capacity: BLT7A, BLTZ7A | 34 amp.-hr. at 20-hr. rate. |
| BT7A, BTZ7A | 43 amp.-hr. at 20-hr. rate. |
| Starter motor | Lucas M35G. |
| Dynamo | Lucas C40. |
| Maximum output | 22 amps. at 2,250 r.p.m. |
| Cut-in speed | 1,450 r.p.m. at 13.5 volts. |
| Control box | Lucas RB106/2. |
| Cut-out: Cut-in voltage | 12.7 to 13.3. |
| Drop-off voltage | 8.5 to 11.0. |
| Reverse current | 5.0 amps. (max.). |
| Regulator (at 3,000 r.p.m. dynamo speed): | |
| Open-circuit setting at 20° C. (68° F.) | 16.0 to 16.6 volts. |
| For ambient temperatures other than 20° C. (68° F.) the following allowances should be made to the above setting: | |
| For every 10° C. (18° F.) above 20° C. (68° F.) subtract .1 volt. | |
| For every 10° C. (18° F.) below 20° C. (68° F.) add .1 volt. | |
| Alternator | Lucas 11AC (12 volts). |
| Maximum output | 43 amperes. |
| Rotor windings: Resistance | 3.8 ± .2 ohms at 20° C. (68° F.). |
| Current | 3.2 amps. at 12 volts. |

GENERAL DATA

MINI MK. I & II (848 c. c.) & MK. II (998 c. c.)—*continued*

| | |
|---|--------------------------------|
| Minimum brush length | $\frac{5}{8}$ in. (3.97 mm.). |
| Brush spring pressure: | |
| $\frac{3}{8}$ in. (19.84 mm.) compressed length | 4 to 5 oz. (113 to 142 gm.). |
| $\frac{1}{2}$ in. (10.32 mm.) compressed length | 7½ to 8½ oz. (212 to 241 gm.). |
| Control unit | |
| Type | Lucas 4TR. |
| Voltage setting at 3,000 alternator r.p.m. | 13.9 to 14.3 volts. |
| Circuit resistance (max.) | .1 ohm. |
| Field isolating relay | Lucas 6RA. |
| Warning light control | Lucas 3AW. |

GENERAL DIMENSIONS

| | | |
|--|--|------------------|
| Wheelbase: Saloon | 6 ft. 8 $\frac{1}{2}$ in. (2.036 m.). | |
| Van, Pick-up, Traveller, and Countryman | 7 ft. 0 $\frac{1}{2}$ in. (2.138 m.). | |
| Moke | 6 ft. 8 $\frac{1}{8}$ in. (2.036 m.). | |
| Overall length: Saloon | 10 ft. 0½ in. (3.05 m.). | |
| Van, Traveller, and Countryman | 10 ft. 9 $\frac{1}{8}$ in. (3.259 m.). | |
| Pick-up | 10 ft. 10½ in. (3.315 m.). | |
| Moke | 10 ft. 0 in. (3.04 m.). | |
| Overall width | 4 ft. 7½ in. (1.41 m.). | |
| Moke | 4 ft. 3½ in. (1.36 m.). | |
| Overall height: Saloon | 4 ft. 5 in. (1.35 m.). | |
| Van | 4 ft. 6½ in. (1.38 m.). | |
| Traveller, Countryman, and Pick-up | 4 ft. 5½ in. (1.36 m.). | |
| Moke | 4 ft. 8 in. (1.42 m.). | |
| Ground clearance | 6 $\frac{1}{2}$ in. (15.63 cm.). | |
| Moke | 6½ in. (16.2 cm.). | |
| Track: Front | 47 $\frac{7}{8}$ in. (1.205 m.). | |
| Rear | 45 $\frac{7}{8}$ in. (1.164 m.). | |
| Turning circle: Saloon | 31 ft. 7 in. (9.63 m.) | } Mk. I models. |
| Van, Pick-up, Traveller, and Countryman | 32 ft. 9 in. (9.893 m.) | |
| Moke | 31 ft. (9.4 m.) | |
| Turning circle: Saloon | 28 ft. 6 in. (8.55 m.) | } Mk. II models. |
| Van, Pick-up, Traveller, and Countryman | 29 ft. (8.84 m.) | |
| Kerbside weight: Saloon (Rubber suspension models) | 1,294 lb. (587 kg.). | |
| Saloon (Hydrolastic suspension models) | 1,398 lb. (634.5 kg.). | |
| Van | 1,334 lb. (605 kg.) approx. | |
| Traveller and Countryman | 1,456 lb. (660 kg.) approx. | |
| Pick-up | 1,328 lb. (603 kg.) approx. | |
| Moke | 1,240 lb. (562 kg.). | |
| Maximum permissible towing weight (suitable for 1 in 8 gradient in bottom gear): | | |
| Saloon and Moke | 8 cwt. (406.4 kg.). | |
| Van, Pick-up, Traveller, and Countryman | 6 cwt. (304.7 kg.). | |

WEIGHT OF COMPONENTS

| | |
|--|--------------------|
| Engine and transmission assembly | 333 lb. (151 kg.). |
|--|--------------------|

GENERAL DATA

MINI MK. I & II (848 c.c.) & MK. II (998 c.c.)—*continued*

CAPACITIES

| | |
|--|---|
| Transmission casing (including filter) | 8½ pints (10.2 U.S. pints, 4.83 litres). |
| Cooling system | 5½ pints (6.3 U.S. pints, 3 litres). |
| With heater | 6¼ pints (7.5 U.S. pints, 3.55 litres). |
| Fuel tank: Saloon | 5½ gallons (6.6 U.S. gallons, 25 litres). |
| Van and Pick-up | 6 gallons (7.2 U.S. gallons, 27.3 litres). |
| Traveller and Countryman: Early models .. | 6½ gallons (7.8 U.S. gallons, 29.6 litres). |
| Later models with underfloor tank | 6 gallons (7.2 U.S. gallons, 27.3 litres). |

TORQUE WRENCH SETTINGS

| Engine | <i>lb. ft.</i> | <i>kg. m.</i> |
|---|----------------|---------------|
| Connecting rod big-end bolts | 35 | 4.8 |
| Crankshaft pulley nut | 70 | 9.6 |
| Cylinder head stud nuts | 40 | 5.5 |
| Cylinder side cover | 2 | .28 |
| Second type—deep pressed cover | 5 | .7 |
| Clutch spring housing to pressure plate set screws .. | 16 | 2.2 |
| Driving strap to flywheel set screw | 16 | 2.2 |
| Flywheel centre-bolt | 110 to 115 | 15.2 to 15.9 |
| Flywheel housing bolts and stud nuts | 18 | 2.5 |
| Gudgeon pin clamp screws | 25 | 3.4 |
| Main bearing set screws | 60 | 8.3 |
| Manifold to cylinder head | 15 | 2.1 |
| Oil filter bowl | 10 to 15 | 1.4 to 2 |
| Oil pump | 9 | 1.2 |
| Rocker cover | 4 | .56 |
| Rocker shaft bracket nuts | 25 | 3.4 |
| Timing cover—¼ in. UNF. bolts | 6 | .8 |
| Timing cover—⅜ in. UNF. bolts | 14 | 1.9 |
| Water pump | 17 | 2.3 |
| Water outlet elbow | 8 | 1.1 |

Gearbox and transmission

| | | |
|--|----------|------------|
| First motion shaft nut | 150 | 20.7 |
| Third motion shaft nut | 150 | 20.7 |
| Transmission case to crankcase | 6 | .8 |
| Transmission drain plug | 40 to 50 | 5.5 to 6.9 |
| Transmission case studs—¾ in. dia. UNC. | 8 | 1.1 |
| Transmission case studs—⅝ in. dia. UNC. | 6 | .8 |
| Transmission case stud nuts—¾ in. UNF. | 25 | 3.4 |
| Transmission case stud nuts—⅝ in. UNF. | 18 | 2.5 |
| Bottom cover set screws—¼ in. dia. UNC. (change-speed tower) | 6 | .8 |

Final drive

| | | |
|--|----|--|
| Driven gear to differential cage | 60 | 8.3 |
| Driving flange to differential nut | 70 | 9.6 (and align to next split pin hole) |
| End cover bolts (differential housing) | 18 | 2.5 |

GENERAL DATA

MINI MK. I & II (848 c.c.) & MK. II (998 c.c.)—*continued*

TORQUE WRENCH SETTINGS

| Suspension and steering | <i>lb. ft.</i> | <i>kg. m.</i> |
|--|----------------|--------------------------|
| Front hub nut (drive shaft) | 60 | 8.3 |
| Front suspension upper arm pivot pin nut | 26 to 28 | 3.6 to 3.9 |
| Rear suspension stub axle nut | 60 | 8.3 (align to next slot) |
| Road wheel nuts | 42 | 5.8 |
| Steering-column/rack pinion clamp bolt | 8 to 9 | 1 to 1.2 |
| Steering lever to hub bolts | 35 | 4.8 |
| Steering lever ball joint nut | 20 to 24 | 2.8 to 3.3 |
| Steering knuckle ball pin bottom nut | 35 to 40 | 4.8 to 5.5 |
| Steering knuckle ball pin top nut | 35 to 40 | 4.8 to 5.5 |
| Steering knuckle ball pin retainer | 70 | 9.6 |
| Steering-wheel nut | 32 to 37 | 4.5 to 5.0 |

| Alternator (IIAC) | <i>lb. in.</i> | <i>kg. m.</i> |
|---------------------------------|----------------|---------------|
| Brush box fixing screws | 10 | .115 |
| Diode heat sink fixings | 25 | .288 |
| Through-bolts | 45 to 50 | .518 to .576 |

| Distributor | | <i>kg. m.</i> |
|--|----|---------------|
| Distributor clamp bolt: Fixed nut type | 50 | .576 |
| Fixed bolt type | 30 | .345 |

GENERAL DATA

MINI COOPER 997 c.c. & 998 c.c.

The following information is applicable to the Mini-Cooper and should be used in conjunction with the preceding specification for the Mini Mk. I and II (848 c.c.) and Mk. II (998 c.c.).

| | (997 c.c.) | (998 c.c.) |
|---|--|---|
| ENGINE | | |
| Type | 9F. | 9FA. |
| Number of cylinders | 4. | 4. |
| Bore | 2.458 in. (62.43 mm.). | 2.543 in. (64.588 mm.). |
| Stroke | 3.20 in. (81.28 mm.). | 3.00 in. (76.2 mm.). |
| Capacity | 60.87 cu. in. (997 c.c.). | 60.96 cu. in. (998 c.c.). |
| B.M.E.P.: High compression | 134 lb./sq. in. (9.42 kg./cm. ²) at 3,500 r.p.m. | 142 lb./sq. in. (10 kg./cm. ²) at 3,000 r.p.m. |
| Low compression | 129 lb./sq. in. (9.07 kg./cm. ²) at 3,500 r.p.m. | 135 lb./sq. in. (9.5 kg./cm. ²) at 3,000 r.p.m. |
| Torque: High compression | 54 lb. ft. (7.46 kg. m.) at 3,600 r.p.m. | 57 lb. ft. (7.881 kg. m.) at 3,000 r.p.m. |
| Low compression | 53 lb. ft. (7.32 kg. m.) at 3,500 r.p.m. | 56 lb. ft. (7.74 kg. m.) at 2,900 r.p.m. |
| CRANKSHAFT | | |
| Main bearings | | |
| Material | Steel-backed copper-lead or aluminium-tin; thin wall. | |
| Running clearance | .001 to .0027 in. (.025 to .069 mm.). | |
| Length | 1.0625 in. (26.99 mm.). | |
| CONNECTING RODS | | |
| Big-end bearings | | |
| Material | Steel-backed copper-lead or aluminium-tin; thin wall. | |
| Bearing length | .875 in. (22.22 mm.). | |
| PISTONS | | |
| Type | Solid skirt. | Solid skirt. |
| Clearance: | | |
| Bottom of skirt (pressure face) | .0016 to .0022 in. (.041 to .056 mm.). | .0005 to .0011 in. (.013 to .028 mm.). |
| Oversizes: 1st | +.010 in. (.254 mm.). | |
| 2nd | +.020 in. (.508 mm.). | |
| PISTON RINGS | | |
| Compression: Top | Plain, chrome-faced. | |
| Second and third | Tapered. | |
| Width | .0620 to .0625 in. (1.574 to 1.588 mm.). | |
| Thickness (all rings) | .106 to .112 in. (2.692 to 2.835 mm.). | |
| GUDGEON PIN | | |
| Type | Fully floating, with circlip location. | |
| Fit in piston | .0001 in. (.0025 mm.) tight to .00035 in. (.0089 mm.) slack. | |
| Fit in small end | .0002 in. (.005 mm.) slack, to size. | |
| Diameter | .6244 in. (15.86 mm.) to .6247 in. (15.867 mm.). | |

GENERAL DATA

MINI-COOPER (997 c.c. & 998 c.c.)—continued

| | (997 c.c.) | (998 c.c.) |
|--------------------------------|------------------------|------------------------|
| VALVES AND VALVE GEAR | | |
| Valves | | |
| Throat diameter: Inlet | ·098 in. (23·06 mm.). | 1·172 in. (29·77 mm.). |
| Exhaust | ·312 in. (7·92 mm.). | ·908 in. (23·06 mm.). |
| Head diameter: Inlet | 1·156 in. (29·4 mm.). | 1·219 in. (30·86 mm.). |
| Exhaust | 1·000 in. (25·40 mm.). | 1·00 in. (25·4 mm.). |
| Valve lift | 1·0312 in. (26·2 mm.). | ·312 in. (7·92 mm.). |
| Inlet valve: Opens | 16° B.T.D.C. | 5° B.T.D.C. |
| Closes | 56° A.B.D.C. | 45° A.B.D.C. |
| Exhaust valve: Opens | 51° B.B.D.C. | 51° B.B.D.C. |
| Closes | 21° A.T.D.C. | 21° A.T.D.C. |

* With ·019 in. (·48 mm.) valve rocker clearance (for checking purposes only).

VALVE SPRINGS

| | |
|---------------------------------------|------------------------|
| Free length: Inner | 1·672 in. (42·47 mm.). |
| Outer | 1·750 in. (44·45 mm.). |
| Pressure: Inner: Valve closed | 18 lb. (8·17 kg.). |
| Valve open | 30 lb. (13·6 kg.). |
| Outer: Valve closed | 55½ lb. (25·13 kg.). |
| Valve open | 88 lb. (39·9 kg.). |

CAMSHAFT

| | |
|---|--|
| Journal diameters: Front | 1·6655 to 1·666 in. (42·304 to 42·316 mm.). |
| Centre | 1·62275 to 1·62325 in. (41·218 to 41·231 mm.). |
| Rear | 1·3725 to 1·3735 in. (34·862 to 34·887 mm.). |
| End-float | ·003 to ·007 in. (·076 to ·178 mm.). |
| Bearings: Number and type | 3. Steel-backed white metal. |
| Inside diameter (reamed in position): Front | 1·667 to 1·6675 in. (42·342 to 42·355 mm.). |
| Centre | 1·6245 to 1·6255 in. (41·261 to 41·287 mm.). |
| Rear | 1·3748 to 1·3755 in. (34·914 to 34·937 mm.). |

ENGINE LUBRICATION SYSTEM

Oil pump

| | |
|--|--|
| Type | Concentric or Hobourn-Eaton. |
| Relief pressure valve operates | 70 lb./sq. in. (4·92 kg./cm. ²). |
| Relief valve spring: Free length | 2¾ in. (66·28 mm.). |
| Fitted length | 2½ in. (54·77 mm.). |

Oil pressure

| | |
|--------------------------|--|
| Normal running | 70 lb./sq. in. (4·92 kg./cm. ²). |
| Idling (minimum) | 15 lb./sq. in. (1·05 kg./cm. ²). |

FUEL SYSTEM

Carburettor refer to 'TUNING DATA'.

Fuel pump

| | |
|---------------------------|---|
| Make and type | S.U. electric. Type SP. |
| Delivery rate | 56 pts./hr. (67·2 U.S. pts./hr., 32 litres/hr.). |
| Delivery pressure | 2½ to 3 lb./sq. in. (·18 to ·21 kg./cm. ²). |

GENERAL DATA

MINI-COOPER (997 c.c. & 998 c.c.)—continued

AIR CLEANERS

| | |
|----------------------|-------------------|
| Type | Oil-wetted gauze. |
| Later models | Paper elements. |

IGNITION SYSTEM

| | |
|----------------|---------------------------|
| Coil | } Refer to 'TUNING DATA'. |
| Distributor | |
| Sparking plugs | |

CLUTCH

| | |
|--------------------------------------|-------------------------------|
| Pressure springs—colour | Black enamel with white spot. |
| Diaphragm spring colour code | Light green. |

GEARBOX

| | | |
|-----------------------------|-----------------|------------------------------|
| Ratios: Top | 1·0 : 1. | |
| Third | 1·357 : 1. | |
| Second | 1·916 : 1. | |
| First | 3·2 : 1. | |
| Reverse | 3·2 : 1. | |
| | <i>Standard</i> | <i>Available alternative</i> |
| Overall ratios: Top | 3·765 : 1. | 3·444 : 1. |
| Third | 5·11 : 1. | 4·674 : 1. |
| Second | 7·213 : 1. | 6·598 : 1. |
| First | 12·05 : 1. | 11·03 : 1. |
| Reverse | 12·05 : 1. | 11·03 : 1. |

DIFFERENTIAL

| | |
|---------------|--|
| Ratio | 3·765 : 1 standard. 3·444 : 1 optional (available as a Service item only). |
|---------------|--|

BRAKES

| | |
|-------------------------------|--|
| Brake fluid | Lockheed (Series 329). |
| Front | |
| Type | Disc. |
| Disc diameter | 7 in. (177·8 mm.). |
| Pad area (total) | 13·8 sq. in. (89 cm. ²). |
| Swept area (total) | 101 sq. in. (651·5 cm. ²). |
| Pad material | M78 (Red/green/red/green/red). |
| Minimum pad thickness | $\frac{1}{8}$ in. (1·6 mm.). |
| Rear | |
| Drum size | 7 in. (17·8 cm.) diameter. |
| Lining dimensions | 6·75 × 1·5 in. (17·4 × 3·8 cm.). |
| Lining area total | 40·5 sq. in. (261·29 cm. ²). |
| Lining material | Don 202. |

GENERAL DATA

MINI-COOPER (997 c.c. & 998 c.c.)—*continued*

GENERAL DIMENSIONS

| | |
|---|----------------------|
| Kerbside weight: Rubber suspension models | 1,400 lb. (635 kg.). |
| Hydrostatic suspension models | 1,433 lb. (650 kg.). |
| Maximum permissible towing weight (suitable for 1 in 8 gradient in bottom gear): | 8 cwt. (406.4 kg.). |

TORQUE WRENCH SETTINGS

| | <i>lb. ft.</i> | <i>kg. m.</i> |
|-----------------------------------|----------------|---------------|
| Calliper retaining bolts | 35 to 40 | 4.8 to 5.5 |
| Steering lever ball joint | 25 to 30 | 3.4 to 4.1 |

GENERAL DATA

MINI-COOPER 'S' MK. I (970 c.c., 1071 c.c. & 1275 c.c.) and COOPER 'S' MK. II & III (1275 c.c.)

The following information is applicable to the Mini-Cooper 'S' and should be used in conjunction with the preceding specifications. See Workshop Manual Supplement AKD 4957 for engine tuning data on cars fitted with exhaust emission control equipment (Exhaust Port Air Injection).

ENGINE

| | | |
|--|---------|---|
| Number of cylinders | | 4. |
| Bore (all models) | | 2.780 in. (70.6 mm.). |
| Stroke: 970 c.c. | | 2.4375 in. (61.91 mm.). |
| 1071 c.c. | | 2.687 in. (68.26 mm.). |
| 1275 c.c. | | 3.2 in. (81.33 mm.). |
| Cubic capacity: 970 c.c. | | 59.1 cu. in. (970 c.c.). |
| 1071 c.c. | | 63.35 cu. in. (1071 c.c.). |
| 1275 c.c. | | 77.9 cu. in. (1275 c.c.). |
| Capacity of combustion chamber (valves and sparking plug fitted) | | 1.306 cu. in. (21.4 c.c.). |
| B.M.F.P.: 970 c.c. | | 142 lb./sq. in. (9.98 kg./cm. ²) at 4,500 r.p.m. |
| 1071 c.c. | | 143 lb./sq. in. (10.05 kg./cm. ²) at 4,500 r.p.m. |
| 1275 c.c. | | 153 lb./sq. in. (10.76 kg./cm. ²) at 3,000 r.p.m. |
| Torque: 970 c.c. | | 57 lb. ft. (7.88 kg. m.) at 5,000 r.p.m. |
| 1071 c.c. | | 62 lb. ft. (8.58 kg. m.) at 4,500 r.p.m. |
| 1275 c.c. | | 79 lb. ft. (10.92 kg. m.) at 3,000 r.p.m. |

CRANKSHAFT

| | | |
|--------------------------|---------|--|
| Main journal diameter | | 2.0005 to 2.0010 in. (50.81 to 50.82 mm.). |
| Minimum regrind diameter | | 1.9805 to 1.9810 in. (50.30 to 50.31 mm.). |
| Main bearings | | |
| Material | | Steel-backed copper-lead; thin wall. |
| Length | | 1.000 in. (25.4 mm.). |
| Running clearance | | .001 to .0027 in. (.025 to .068 mm.). |

CONNECTING RODS

| | | |
|--------------------------|---------|--|
| Little-end bore diameter | | .8110 to .8115 in. (20.60 to 20.61 mm.). |
|--------------------------|---------|--|

PISTONS

| | | |
|--|---------|--|
| Type | | Solid skirt. |
| Clearance: Bottom of skirt (pressure face) | | .0019 to .0025 in. (.048 to .063 mm.). |
| Top of skirt | | .025 to .0283 in. (.63 to .72 mm.). |

PISTON RINGS

| | | |
|---------------------|---------|--|
| Compression: Plain | | Top ring. |
| Tapered | | Second and third ring. |
| Width | | .0459 to .0469 in. (1.16 to 1.19 mm.). |
| Thickness | | .116 to .122 in. (29.4 to 30.9 mm.). |
| Fitting gap | | .008 to .013 in. (.20 to .33 mm.). |
| Clearance in groove | | .0015 to .0035 in. (.04 to .09 mm.). |
| Oil control type | | |
| Width | | .1153 to .1563 in. (3.94 to 3.96 mm.). |
| Thickness | | .116 to .122 in. (29.4 to 30.9 mm.). |
| Fitted gap | | .008 to .013 in. (.20 to .33 mm.). |
| Clearance in groove | | .0015 to .0035 in. (.04 to .09 mm.). |

GENERAL DATA

MINI-COOPER 'S' MK. I (970 c.c., 1071 c.c., & 1275 c.c.), & COOPER 'S'
MK. II & III (1275 c.c.)—continued

GUDGEON PIN

| | |
|-------------------------------|---|
| Type | Pressed in connecting rod. |
| Fit in piston | Hand push-fit. |
| Diameter (outer) | .8123 to .8125 in. (20.63 to 20.64 mm.). |
| Fit in connecting rod | .0008 to .0015 in. (.020 to .038 mm.) interference. |

VALVES AND VALVE GEAR

Valves

| | |
|--|--|
| Head diameter: Inlet | 1.401 to 1.406 in. (35.58 to 35.71 mm.). |
| Exhaust | 1.214 to 1.219 in. (30.83 to 30.96 mm.). |
| Valve lift | .318 in. (8.08 mm.), nominal. |
| Stem diameter: Exhaust | .2788 to .2793 in. (7.08 to 7.09 mm.). |
| Inlet | .2793 to .2798 in. (7.09 to 7.11 mm.). |
| Valve rocker clearance: Standard | .012 in. (.30 mm.) cold. |
| Competition | .015 in. (.38 mm.) cold. |
| Timing | .021 in. (.53 mm.). |
| Inlet valve: Opens | 5° B.T.D.C. |
| Closes | 45° A.B.D.C. |
| Exhaust valve: Opens | 51° B.B.D.C. |
| Closes | 21° A.T.D.C. |

} with .021 in. (.53 mm.) valve
rocker clearance (for checking
purposes only).

VALVE SPRINGS

| | |
|--|------------------------|
| Free length: Inner | 1.705 in. (43.31 mm.). |
| Outer | 1.740 in. (44.19 mm.). |
| Number of working coils: Inner | 6½. |
| Outer | 4½. |
| Pressure: Inner: Valve closed | 26.6 lb. (12.065 kg.). |
| Valve open | 46 lb. (20.865 kg.). |
| Outer: Valve closed | 49.6 lb. (22.498 kg.). |
| Valve open | 94 lb. (42.638 kg.). |

CAMSHAFT

| | |
|--|---|
| Journal diameter: Rear | 1.37275 to 1.3735 in. (34.87 to 34.88 mm.). |
| Inside diameter (reamed in position): Rear | 1.3745 to 1.3750 in. (34.91 to 34.92 mm.). |
| Running clearance: Rear | .001 to .00225 in. (.025 to .057 mm.). |
| Bearing length: Rear | 6.5 ± .010 in. (19.45 ± .25 mm.). |

ENGINE LUBRICATION SYSTEM

| | |
|---------------------------------------|--|
| Oil pressure (normal running) | 60 lb./sq. in. (4.22 kg./cm. ²) at 70° C. (158° F.) oil temperature. |
|---------------------------------------|--|

COOLING SYSTEM

| | |
|----------------------------|-------------------|
| Thermostat setting | 82° C. (180° F.). |
| Cold climates | 88° C. (188° F.). |
| Hot climates | 74° C. (165° F.). |

FUEL SYSTEM

Carburettor refer to 'TUNING DATA'.

GENERAL DATA

MINI-COOPER 'S' MK. I (970 c.c., 1071 c.c., & 1275 c.c.), & COOPER 'S'
MK. II & III (1275 c.c.)—*continued*

CLUTCH

| | | | | | | | |
|--------------------------------------|----|----|----|----|----|----|------------------------|
| Make and type: Early type | .. | .. | .. | .. | .. | .. | BMC single dry plate. |
| Later type | .. | .. | .. | .. | .. | .. | Diaphragm spring. |
| Diameter | .. | .. | .. | .. | .. | .. | 7.125 in. (180.9 mm.). |
| Facing material: Standard | .. | .. | .. | .. | .. | .. | Wound yarn, riveted. |
| Pressure springs (early type): Inner | .. | .. | .. | .. | .. | .. | 6. |
| Outer | .. | .. | .. | .. | .. | .. | 6. |
| Colour: Inner | .. | .. | .. | .. | .. | .. | Green spot. |
| Outer | .. | .. | .. | .. | .. | .. | White spot. |

GEARBOX (3-speed Synchromesh)

| | | | | | | | |
|-------------|----|----|----|----|----|-----------------|-------------------------------|
| | | | | | | <i>Standard</i> | <i>Optional (close ratio)</i> |
| Ratios: Top | .. | .. | .. | .. | .. | 1.0 : 1 | 1.0 : 1 |
| Third | .. | .. | .. | .. | .. | 1.357 : 1 | 1.242 : 1 |
| Second | .. | .. | .. | .. | .. | 1.916 : 1 | 1.78 : 1 |
| First | .. | .. | .. | .. | .. | 3.200 : 1 | 2.57 : 1 |
| Reverse | .. | .. | .. | .. | .. | 3.200 : 1 | 2.57 : 1 |

Overall gear ratios (as applicable):

Standard gearbox

| | | | | | | | | | | |
|--------------------------|----|----|----|----|----|----|----------------------------|------------|------------|------------|
| | | | | | | | <i>1st and reverse</i> | <i>2nd</i> | <i>3rd</i> | <i>4th</i> |
| <i>Final drive ratio</i> | | | | | | | | | | |
| 3.765 (17/64) | .. | .. | .. | .. | .. | .. | 12.05 : 1 | 7.21 : 1 | 5.11 : 1 | 3.765 : 1 |
| 3.444 (18/62) | .. | .. | .. | .. | .. | .. | 11.02 : 1 | 6.60 : 1 | 4.67 : 1 | 3.444 : 1 |
| 3.939 (16/63) | .. | .. | .. | .. | .. | .. | 12.06 : 1 | 7.54 : 1 | 5.34 : 1 | 3.939 : 1 |
| 4.133 (15/62) | .. | .. | .. | .. | .. | .. | 13.27 : 1 | 7.92 : 1 | 5.61 : 1 | 4.133 : 1 |
| 4.267 (15/64) | .. | .. | .. | .. | .. | .. | 13.65 : 1 | 8.18 : 1 | 5.79 : 1 | 4.267 : 1 |

Optional gearbox (close ratio)

| | | | | | | | | | | |
|--------------------------|----|----|----|----|----|----|----------------------------|------------|------------|------------|
| | | | | | | | <i>1st and reverse</i> | <i>2nd</i> | <i>3rd</i> | <i>4th</i> |
| <i>Final drive ratio</i> | | | | | | | | | | |
| 3.444 (18/62) | .. | .. | .. | .. | .. | .. | 8.84 : 1 | 6.13 : 1 | 4.28 : 1 | 3.444 : 1 |
| 3.647 (17/62) | .. | .. | .. | .. | .. | .. | 9.37 : 1 | 6.49 : 1 | 4.53 : 1 | 3.647 : 1 |
| 3.765 (17/64) | .. | .. | .. | .. | .. | .. | 9.66 : 1 | 6.70 : 1 | 4.68 : 1 | 3.765 : 1 |
| 3.939 (16/63) | .. | .. | .. | .. | .. | .. | 10.12 : 1 | 7.02 : 1 | 4.89 : 1 | 3.939 : 1 |
| 4.133 (15/62) | .. | .. | .. | .. | .. | .. | 10.61 : 1 | 7.35 : 1 | 5.13 : 1 | 4.133 : 1 |
| 4.267 (15/64) | .. | .. | .. | .. | .. | .. | 10.90 : 1 | 7.61 : 1 | 5.30 : 1 | 4.267 : 1 |
| 4.35 (15/65) | .. | .. | .. | .. | .. | .. | 11.18 : 1 | 7.74 : 1 | 5.40 : 1 | 4.35 : 1 |

Road speed in top at 1,000 r.p.m.

| | | | | | | | |
|--------------|----|----|----|----|----|----|-------------------------------|
| <i>Ratio</i> | | | | | | | |
| 3.444 | .. | .. | .. | .. | .. | .. | 16.07 m.p.h. (25.71 km.p.h.). |
| 3.647 | .. | .. | .. | .. | .. | .. | 15 m.p.h. (24.14 km.p.h.). |
| 3.765 | .. | .. | .. | .. | .. | .. | 14.7 m.p.h. (23.52 km.p.h.). |
| 3.939 | .. | .. | .. | .. | .. | .. | 14.06 m.p.h. (22.5 km.p.h.). |
| 4.133 | .. | .. | .. | .. | .. | .. | 13.4 m.p.h. (21.44 km.p.h.). |
| 4.267 | .. | .. | .. | .. | .. | .. | 12.96 m.p.h. (20.74 km.p.h.). |
| 4.35 | .. | .. | .. | .. | .. | .. | 12.57 m.p.h. (20.23 km.p.h.). |

DIFFERENTIAL

| | | | | | | | |
|--------------------------|----|----|----|----|----|----|-------------------------------------|
| Ratio—standard: 970 c.c. | .. | .. | .. | .. | .. | .. | 3.765 : 1. |
| 1071 c.c. | .. | .. | .. | .. | .. | .. | 3.765 : 1. |
| 1275 c.c. (Mk. I and II) | .. | .. | .. | .. | .. | .. | 3.444 : 1. |
| Alternative ratios | .. | .. | .. | .. | .. | .. | 3.939 : 1, 4.267 : 1, and 4.35 : 1. |

GENERAL DATA

MINI-COOPER 'S' MK. I (970 c.c., 1071 c.c., & 1275 c.c.), & COOPER 'S'
MK. II & III (1275 c.c.)—continued

GEARBOX (4-speed Synchronesh)

| | Standard (close ratio) | | | | | |
|-------------|------------------------|----|----|----|----|-------------|
| Ratios: Top | .. | .. | .. | .. | .. | .. 1.0 : 1 |
| Third | .. | .. | .. | .. | .. | .. 1.35 : 1 |
| Second | .. | .. | .. | .. | .. | .. 2.07 : 1 |
| First | .. | .. | .. | .. | .. | .. 3.30 : 1 |
| Reverse | .. | .. | .. | .. | .. | .. 3.35 : 1 |

Overall gear ratios (4-speed synchronesh)

| <i>Final drive ratio</i> | | <i>Reverse</i> | <i>1st</i> | <i>2nd</i> | <i>3rd</i> |
|-----------------------------------|----|-------------------------------|------------|------------|------------|
| 3.65 : 1 (17/62) | .. | .. 12.21 | .. 12.04 | .. 7.56 | .. 4.93 |
| Road speed in top at 1,000 r.p.m. | | | | | <i>4th</i> |
| <i>Ratio</i> | | | | | 3.65 |
| 3.65 : 1 | .. | .. 15 m.p.h. (24.14 km.p.h.). | | | |

DIFFERENTIAL

| | | | | | | |
|---------------------------|----|----|----|----|----|--|
| Ratio—standard: 1275 c.c. | .. | .. | .. | .. | .. | .. 3.65 : 1. |
| Alternative ratios | .. | .. | .. | .. | .. | .. 3.939 : 1, 4.267 : 1, and 4.35 : 1. |

BRAKES

| | | | | | | |
|---|----|----|----|----|----|--|
| Type | .. | .. | .. | .. | .. | .. Lockheed hydraulic with vacuum servo. |
| Servo Unit | | | | | | |
| Type: (Mk. I and II models) | .. | .. | .. | .. | .. | .. Lockheed 5½ in. (140 mm.). |
| (Mk. III models) | .. | .. | .. | .. | .. | .. Lockheed type 6. |
| Front | | | | | | |
| Type | .. | .. | .. | .. | .. | .. Disc. |
| Disc diameter | .. | .. | .. | .. | .. | .. 7½ in. (190.5 mm.). |
| Pad material (Up to Commission No. 000573A) | .. | .. | .. | .. | .. | .. Ferodo DA6. |
| (From Commission No. 000574A) | .. | .. | .. | .. | .. | .. Mintex M78 (Red/green/red/green/red). |
| Pad area (total) | .. | .. | .. | .. | .. | .. 17.3 sq. in. (111.4 cm. ²). |
| Swept area (total) | .. | .. | .. | .. | .. | .. 122 sq. in. (787 cm. ²). |
| Minimum pad thickness | .. | .. | .. | .. | .. | .. ⅛ in. (1.6 mm.). |

FRONT HUBS

| | | | | | | |
|----------|----|----|----|----|----|-------------------------|
| Bearings | .. | .. | .. | .. | .. | .. Timkin taper roller. |
|----------|----|----|----|----|----|-------------------------|

WHEELS

| | | | | | | |
|-----------------------|----|----|----|----|----|-----------------------------|
| Type: Ventilated disc | .. | .. | .. | .. | .. | .. 3.50B × 10 or 4.5J × 10. |
|-----------------------|----|----|----|----|----|-----------------------------|

TYRES

| | | | | | | |
|---|----|----|----|----|----|---|
| Size: Standard | .. | .. | .. | .. | .. | .. 145—10 SP, tubed, or 5.20—10 C41 tubed. |
| Optional | .. | .. | .. | .. | .. | .. 500L—10, tubed. |
| Tyre pressures (145—10SP and 5.20—10 C41 only): | | | | | | |
| Front | .. | .. | .. | .. | .. | .. 28 lb./sq. in. (1.97 kg./cm. ²). |
| Rear | .. | .. | .. | .. | .. | .. 26 lb./sq. in. (1.83 kg./cm. ²). |

GENERAL DATA

MINI-COOPER 'S' MK. I (970 c.c., 1071 c.c., & 1275 c.c.), & COOPER 'S'
MK. II & III (1275 c.c.)—*continued*

CAPACITIES

| | |
|--|------------------------|
| Fuel tank: (early models) | 5½ galls. (25 litres). |
| Twin tanks (later Mk. II and Mk. III models) | 11 galls. (50 litres). |

GENERAL DIMENSIONS

| | |
|---|-----------------------------------|
| Track: Front: 3.5 in. rim | 47 $\frac{1}{2}$ in. (1.207 m.). |
| 4.5 in. rim | 48 $\frac{1}{2}$ in. (1.233 m.). |
| Rear: 3.5 in. rim | 46 $\frac{1}{8}$ in. (1.176 m.). |
| 4.5 in. rim | 47 $\frac{1}{8}$ in. (1.202 mm.). |
| Kerbside weight: Rubber suspension models | 1,411 lb. (640 kg.) approx. |
| Hydrolastic suspension models | 1,540 lb. (698 kg.) approx. |

TORQUE WRENCH SETTINGS

| | <i>lb. ft.</i> | <i>kg. m.</i> |
|---|----------------|---------------|
| Cylinder head nuts (10 off) | 42 | 5.8 |
| Cylinder head bolt (front, 1 off) | 25 | 3.5 |
| Connecting rod big-end nuts (assemble dry only) | 40 | 5.5 |
| Main bearing set screws (early type) | 67 | 9.3 |
| Main bearing nuts (later type) | 57 | 7.9 |
| Drive shaft nut | 150 | 20.7 |

GENERAL DATA

MINI AUTOMATIC (848 c.c. & 998 c.c.)

The following information is applicable to the Mini Automatic and should be used in conjunction with the preceding specification for the Mini Mk. I and II (848 c.c.) and Mk. II (998 c.c.).

| ENGINE | (848 c.c.) | (998 c.c.) |
|------------------|--|---|
| Type | 8AH. | 9AG. |
| B.H.P. | 39 at 5,250 r.p.m. | 41 at 4,850 r.p.m. |
| B.M.E.P. | | 130 lb./in. ² (9.14 kg./cm. ²) at 2,750 r.p.m. |
| Torque | 44 lb. ft. (6.08 kg. m.) at 2,500 r.p.m. | 52 lb. ft. (7.19 kg. m.) at 2,750 r.p.m. |

LUBRICATION SYSTEM

| | |
|--|--|
| Oil pump | |
| Type | Hobourn-Eaton. |
| Oil filter | |
| Type | Full-flow. |
| Capacity | 1 pint (1.2 U.S. pints, .57 litre) |
| Oil pressure | |
| Normal running speed and temperature | 60 lb./sq. in. (4.22 kg./cm. ²). |
| Idling (minimum) at normal running temperature | 15 lb./sq. in. (1.05 kg./cm. ²). |

FUEL SYSTEM

Carburetter refer to 'TUNING DATA'.

IGNITION SYSTEM

| | |
|----------------|---------------------------|
| Coil | } Refer to 'TUNING DATA'. |
| Distributor | |
| Sparking plugs | |

DIFFERENTIAL

| | |
|---------------|-----------|
| Ratio | 3.27 : 1. |
|---------------|-----------|

AUTOMATIC TRANSMISSION

| | |
|-----------------------------|------------|
| Ratios: Top | 1.0 : 1. |
| Third | 1.46 : 1. |
| Second | 1.845 : 1. |
| First | 2.69 : 1. |
| Reverse | 2.69 : 1. |
| Overall ratios: Top | 3.76 : 1. |
| Third | 5.49 : 1. |
| Second | 6.94 : 1. |
| First | 10.11 : 1. |
| Reverse | 10.11 : 1. |
| Speedometer | 7/17. |

TORQUE CONVERTER

| | |
|-------------------------------------|--|
| Type | 3-element. |
| Ratio | 2 : 1 maximum. |
| Converter output gear ratio | 1.15 : 1. |
| End-float | .0035 to .0065 in. (.089 to .164 mm.). |

GENERAL DATA

MINI AUTOMATIC—continued

DRIVE SHAFTS

Make and type of joint Hardy Spicer, flange joint.

CAPACITIES

Transmission casing (including filter) 13 pints (7.38 litres, 16 U.S. pints).
 Refill capacity (approx.) 9 pints (5 litres, 11 U.S. pints).

WEIGHT OF COMPONENTS

Engine and transmission assembly 357 lb. (162 kg.).
 Automatic transmission 112 lb. (50.8 kg.).

GENERAL DIMENSIONS

Kerbside weight: Mini Mk. I Saloon 1,390 lb. (630.8 kg.).
 Mini Mk. II Saloon
 Mini 850/1000 Saloon } 1,442 lb. (654 kg.).
 Mini Clubman Saloon 1,450 lb. (658 kg.).

TORQUE WRENCH SETTINGS

| | <i>lb. ft.</i> | <i>kg. m.</i> |
|--|----------------|---------------|
| Converter centre bolt | 110 to 115 | 15.2 to 15.9 |
| Converter (six central bolts) | 22 to 24 | 3.0 to 3.3 |
| Converter drain plugs | 18 to 20 | 2.5 to 2.8 |
| Converter housing bolts | 18 | 2.5 |
| Differential driving flange securing bolts | 40 to 45 | 5.5 to 6.2 |
| Gear train bearing caps | 12 | 1.6 |
| Gear train carrier strap | 12 | 1.6 |
| Governor to auxiliary pump housing bolts | 10 to 15 | 1.4 to 2 |
| Kickdown control assembly to transmission casing (on nyloc housing) | 5 | .7 |
| Oil filter bowl | 10 to 15 | 1.4 to 2 |
| Input shaft nut | 70 | 9.6 |
| Servo unit securing bolts | 17 | 2.4 |
| Top and reverse clutch hub nut | 150 | 20.7 |
| Transmission to engine securing nut | 12 | 1.6 |
| Valve block securing bolts | 10 | 1.4 |
| Valve block bolts (securing three sections) | 7 | 0.97 |
| $\frac{1}{8}$ in. UNF. bolts | 18 to 20 | 2.5 to 2.8 |
| $\frac{3}{8}$ in. UNF. bolts | 30 | 4.1 |

GENERAL DATA

MINI 850/1000 SALOON, VAN, & PICK-UP

The following information refers specifically to new or modified components fitted to the above Mini range coincident with the introduction of NEGATIVE earth electrical systems and must be used in conjunction with the preceding specifications for the Mini Mk. I (848-c.c. engine) and the Mini Mk. II (998-c.c. engine).

ENGINE

| | | | | | | | | |
|-----------------|----|----|----|----|----|----|----|------|
| Type (848 c.c.) | .. | .. | .. | .. | .. | .. | .. | 85H. |
| (998 c.c.) | .. | .. | .. | .. | .. | .. | .. | 99H. |

IGNITION SYSTEM

| | | |
|----------------|---|-------------------------|
| Coil | } | Refer to 'TUNING DATA'. |
| Distributor | | |
| Sparking plugs | | |

FUEL SYSTEM

Carburettor refer to 'TUNING DATA'.

Fuel pump

| | | | | | | | | |
|-----------------|----|----|----|----|----|----|----|--|
| Make/type | .. | .. | .. | .. | .. | .. | .. | S.U. mechanical; AUF 700 (AUF 705 model). |
| Suction (min.) | .. | .. | .. | .. | .. | .. | .. | 6 in. (152 mm.) Hg. |
| Pressure (min.) | .. | .. | .. | .. | .. | .. | .. | 3 lb./sq. in. (.21 kg./cm. ²). |

TRANSMISSION (Fitted to 998 c.c.)*

Gearbox

| | | | | | | | | |
|--|----|----|----|----|----|----|----|------------------------------|
| Number of forward speeds | .. | .. | .. | .. | .. | .. | .. | 4. |
| Synchromesh | .. | .. | .. | .. | .. | .. | .. | All forward gears. |
| Ratios: Top | .. | .. | .. | .. | .. | .. | .. | 1.00 : 1. |
| Third | .. | .. | .. | .. | .. | .. | .. | 1.43 : 1. |
| Second | .. | .. | .. | .. | .. | .. | .. | 2.21 : 1. |
| First | .. | .. | .. | .. | .. | .. | .. | 3.52 : 1. |
| Reverse | .. | .. | .. | .. | .. | .. | .. | 3.54 : 1. |
| Overall ratios: Top | .. | .. | .. | .. | .. | .. | .. | 3.44 : 1. |
| Third | .. | .. | .. | .. | .. | .. | .. | 4.93 : 1. |
| Second | .. | .. | .. | .. | .. | .. | .. | 7.63 : 1. |
| First | .. | .. | .. | .. | .. | .. | .. | 12.13 : 1. |
| Reverse | .. | .. | .. | .. | .. | .. | .. | 12.19 : 1. |
| Road speed at 1,000 r.p.m. in top gear | .. | .. | .. | .. | .. | .. | .. | 16.2 m.p.h. (25.75 km.p.h.). |
| Speedometer gear ratio | .. | .. | .. | .. | .. | .. | .. | 4/14 |

Final drive

| | | | | | | | | |
|-------|----|----|----|----|----|----|----|---------------------------------|
| Type | .. | .. | .. | .. | .. | .. | .. | Helical gears and differential. |
| Ratio | .. | .. | .. | .. | .. | .. | .. | 3.44 : 1 (18/62). |

* Van and Pick-up as 848 c.c.

GENERAL DATA

MINI 850/1000 SALOON, VAN, & PICK-UP—continued

TRANSMISSION (Fitted to 848 c.c.)

Gearbox

| | |
|--|-----------------------------|
| Number of forward speeds | 4. |
| Synchromesh | All forward gears. |
| Ratios: Top | 1·00 : 1. |
| Third | 1·43 : 1. |
| Second | 2·21 : 1. |
| First | 3·52 : 1. |
| Reverse | 3·54 : 1. |
| Overall ratios: Top | 3·76 : 1. |
| Third | 5·40 : 1. |
| Second | 8·32 : 1. |
| First | 13·25 : 1. |
| Reverse | 13·30 : 1. |
| Road speed at 1,000 r.p.m. in top gear | 15·2 m.p.h. (24·3 km.p.h.). |
| Speedometer gear ratio | 4/16 |

Final drive

| | |
|---------------|---------------------------------|
| Type | Helical gears and differential. |
| Ratio | 3·76 : 1 (17/64). |

SUSPENSION

| | |
|------------------------------|--|
| Type | Rubber cone spring. (Hydrolastic special market fitment.) |
| Hydraulic dampers | |
| Type: Front and rear | Tubular telescopic. |

ELECTRICAL EQUIPMENT

| | |
|---|---|
| System | 12-volt, negative earth. |
| Charging system | Compensated voltage control. |
| Battery | Lucas CL7 or CLZ7. |
| Capacity | 34 amp.-hr. at 20-hr. rate. |
| Dynamo | Lucas C40. |
| Maximum output | 22 amps. at 2,250 r.p.m. |
| Cut-in speed | 1,450 r.p.m. at 13·5 volts. |
| Control box | Lucas RB106/2. |
| Cut-out: Cut-in voltage | 12·7 to 13·3. |
| Drop-off voltage | 8·5 to 11·0. |
| Reverse current | 5·0 amps. (max.). |
| Regulator (at 3,000 r.p.m. dynamo speed): | |
| Open-circuit setting at 20° C. (68° F.) | 16·0 to 16·6 volts. |
| For ambient temperatures other than 20° C. (68° F.) the following allowances should be made to the above setting: | |
| For every 10° C. (18° F.) above 20° C. (68° F.) subtract ·1 volt. | |
| For every 10° C. (18° F.) below 20° C. (68° F.) add ·1 volt. | |
| Starter motor | Lucas M35G or M35J. |
| M35G Type | |
| Brush spring tension | 15 to 25 oz. (425 to 709 gm.). |
| M35J Type | |
| Brush spring tension | 28 oz. (794 gm.). |
| Light running current | 65 amperes at 8,000–10,000 r.p.m. |
| Lock torque | 7 lb. ft. (·97 kg. m.) with 350–375 amps. |

GENERAL DATA

MINI 850/1000 SALOON, VAN, & PICK-UP—*continued*

| | |
|--|---|
| Alternator | Lucas 16ACR. |
| Nominal output | 34 amps. at 6,000 r.p.m. (engine—2,800 r.p.m.) |
| Nominal system voltage | 14.2 volts at 20% nominal output. |
| Maximum continuous speed | 12,500 r.p.m. |
| Resistance of rotor winding at 20° C. (68° F.) | 4.33 ohms ±5%. |
| Brush spring tension | 7 to 10 oz. (198 to 283 gm.). |
| Windscreen wiper | Lucas 14W. |
| Light running speeds (rack disconnected) | 46 to 52 r.p.m. (normal speed), 60 to 70 r.p.m. (fast speed). |
| Light running current | 1.5 amps. (normal speed), 2 amps. (fast speed). |
| Brush spring pressure | 5 to 7 oz. (140 to 200 gm.). |
| Minimum brush length | $\frac{3}{8}$ in. (4.8 mm.). |
| Armature end-float | .002 to .008 in. (.05 to .2 mm.). |
| Maximum pull to move rack in tube | 6 lb. (2.7 kg.). |
| Windscreen wiper arm spring pressure | 7 to 9 oz. (200 to 255 gm.). |

WEIGHTS

Kerbside weight:

| | |
|-----------------------------------|-----------------------------|
| 850 Saloon (Synchromesh) | 1,363 lb. (619 kg.) approx. |
| 1000 Saloon (Synchromesh) | 1,410 lb. (640 kg.) approx. |
| (Automatic) | 1,442 lb. (654 kg.) approx. |
| Van | 1,334 lb. (605 kg.) approx. |
| Pick-up | 1,328 lb. (603 kg.) approx. |

TORQUE TIGHTENING FIGURES

Alternator (type 16ACR)

| | |
|-------------------|---------------------------------------|
| Shaft nut | 25 to 30 lb. ft. (3.5 to 4.2 kg. m.). |
|-------------------|---------------------------------------|

Refer to page **General Data 6** for all other Torque figures.

GENERAL DATA

MINI CLUBMAN

The following information is applicable to the Mini Clubman and should be used in conjunction with the preceding specification for the Mini Mk. II.

ENGINE

| | | | | | | | | | |
|-------------------------------------|----|----|----|----|----|----|----|----|--|
| Type | .. | .. | .. | .. | .. | .. | .. | .. | 99H. |
| Number of cylinders | .. | .. | .. | .. | .. | .. | .. | .. | 4. |
| Bore | .. | .. | .. | .. | .. | .. | .. | .. | 2.543 in. (64.588 mm.). |
| Stroke | .. | .. | .. | .. | .. | .. | .. | .. | 3.00 in. (76.2 mm.). |
| Capacity | .. | .. | .. | .. | .. | .. | .. | .. | 60.96 cu. in. (998 c.c.). |
| Compression ratio: High compression | .. | .. | .. | .. | .. | .. | .. | .. | 8.3 : 1. |
| Low compression | .. | .. | .. | .. | .. | .. | .. | .. | 7.6 : 1. |
| B.M.E.P.: High compression | .. | .. | .. | .. | .. | .. | .. | .. | 130 lb./sq. in. (9.14 kg./cm. ²) at 2,700 r.p.m. |
| Low compression | .. | .. | .. | .. | .. | .. | .. | .. | ————— |
| Torque: High compression | .. | .. | .. | .. | .. | .. | .. | .. | 52 lb. ft. (7.28 kg. m.) at 2,700 r.p.m. |
| Low compression | .. | .. | .. | .. | .. | .. | .. | .. | ————— |

IGNITION SYSTEM

| | |
|----------------|---------------------------|
| Coil | } Refer to 'TUNING DATA'. |
| Distributor | |
| Sparking plugs | |

FUEL SYSTEM

Carburettor refer to 'TUNING DATA'.

Air cleaner

| | | | | | | | | | |
|------|----|----|----|----|----|----|----|----|--|
| Type | .. | .. | .. | .. | .. | .. | .. | .. | Paper element with warm/cold air intake and silencer tube. |
|------|----|----|----|----|----|----|----|----|--|

Fuel pump

| | | | | | | | | | |
|-----------------|----|----|----|----|----|----|----|----|--|
| Make/type | .. | .. | .. | .. | .. | .. | .. | .. | S.U. mechanical; AUF 700 (AUF 705 model). |
| Suction (min.) | .. | .. | .. | .. | .. | .. | .. | .. | 6 in. (152 mm.) Hg. |
| Pressure (min.) | .. | .. | .. | .. | .. | .. | .. | .. | 3 lb./sq. in. (.21 kg./cm. ²). |

TRANSMISSION

Gearbox

| | | | | | | | | | |
|--|----|----|----|----|----|----|----|----|------------------------------|
| Number of forward speeds | .. | .. | .. | .. | .. | .. | .. | .. | 4. |
| Synchromesh | .. | .. | .. | .. | .. | .. | .. | .. | All forward gears. |
| Ratios: Top | .. | .. | .. | .. | .. | .. | .. | .. | 1.00 : 1. |
| Third | .. | .. | .. | .. | .. | .. | .. | .. | 1.43 : 1. |
| Second | .. | .. | .. | .. | .. | .. | .. | .. | 2.21 : 1. |
| First | .. | .. | .. | .. | .. | .. | .. | .. | 3.52 : 1. |
| Reverse | .. | .. | .. | .. | .. | .. | .. | .. | 3.54 : 1. |
| Overall ratios: Top | .. | .. | .. | .. | .. | .. | .. | .. | 3.44 : 1. |
| Third | .. | .. | .. | .. | .. | .. | .. | .. | 4.93 : 1. |
| Second | .. | .. | .. | .. | .. | .. | .. | .. | 7.63 : 1. |
| First | .. | .. | .. | .. | .. | .. | .. | .. | 12.13 : 1. |
| Reverse | .. | .. | .. | .. | .. | .. | .. | .. | 12.19 : 1. |
| Road speed at 1,000 r.p.m. in top gear | .. | .. | .. | .. | .. | .. | .. | .. | 16.2 m.p.h. (25.75 km.p.h.). |
| Speedometer gear ratio | .. | .. | .. | .. | .. | .. | .. | .. | 4/14 |

Final drive

| | | | | | | | | | |
|-------|----|----|----|----|----|----|----|----|---------------------------------|
| Type | .. | .. | .. | .. | .. | .. | .. | .. | Helical gears and differential. |
| Ratio | .. | .. | .. | .. | .. | .. | .. | .. | 3.44 : 1 (18/62). |

GENERAL DATA

MINI CLUBMAN—continued

STEERING

| | |
|---|--|
| Type | Rack and pinion. |
| Steering-wheel turns—lock to lock | 2.7. |
| Steering-wheel diameter | 15.0 in. (380 mm.). |
| Front wheel alignment | $\frac{1}{8}$ in. (1.6 mm.) toe-out unladen. |

SUSPENSION

Saloon

| | |
|-------------------------------------|--|
| Type | Hydrolastic suspension. |
| Fluid capacity | 4 pints (5 U.S. pints, 2.27 litres), approx. |
| *Fluid pressure (unladen) | 292 lb./sq. in. (20.6 kg./cm. ²), approx. |
| Trim height: Front and rear | $13\frac{1}{2} \pm \frac{1}{4}$ in. (343 \pm 9.5 mm.). |

* Adjust to trim height.

Estate

| | |
|--------------|---------------------|
| Type | Rubber cone spring. |
|--------------|---------------------|

HYDRAULIC DAMPERS (Estate car only)

| | |
|------------------------------|---------------------|
| Type: Front and rear | Tubular telescopic. |
|------------------------------|---------------------|

ELECTRICAL EQUIPMENT

| | |
|---|---|
| System | 12-volt, negative earth. |
| Charging system | Compensated voltage control. |
| Battery | Lucas CL7 or CLZ7. |
| Capacity | 34 amp.-hr. at 20-hr. rate. |
| Dynamo | Lucas C40. |
| Maximum output | 22 amps. at 2,250 r.p.m. |
| Cut-in speed | 1,450 r.p.m. at 13.5 volts. |
| Control box | Lucas RB106/2. |
| Cut-out: Cut-in voltage | 12.7 to 13.3. |
| Drop-off voltage | 8.5 to 11.0. |
| Reverse current | 5.0 amps. (max.). |
| Regulator (at 3,000 r.p.m. dynamo speed): | |
| Open-circuit setting at 20° C. (68° F.) | 16.0 to 16.6 volts. |
| For ambient temperatures other than 20° C. (68° F.) the following allowances should be made to the above setting: | |
| For every 10° C. (18° F.) above 20° C. (68° F.) subtract .1 volt. | |
| For every 10° C. (18° F.) below 20° C. (68° F.) add .1 volt. | |
| Starter motor | Lucas M35G or M35J. |
| <i>M35G Type</i> | |
| Brush spring tension | 15 to 25 oz. (425 to 709 gm.). |
| <i>M35J Type</i> | |
| Brush spring tension | 28 oz. (794 gm.). |
| Light running current | 65 amperes at 8,000–10,000 r.p.m. |
| Lock torque | 7 lb. ft. (.97 kg. m.) with 350–375 amps. |
| Alternator | Lucas 16ACR. |
| Nominal output | 34 amps. at 6,000 r.p.m. |
| Nominal system voltage | 14.2 volts at 20% nominal output. |
| Maximum continuous speed | 12,500 r.p.m. |
| Resistance of rotor winding at 20° C. (68° F.) | 4.33 ohms \pm 5%. |
| Brush spring tension | 7 to 10 oz. (198 to 283 gm.). |

GENERAL DATA

MINI CLUBMAN—continued

| | | | | | | |
|--|----|----|----|----|----|---|
| Windscreen wiper.. | .. | .. | .. | .. | .. | Lucas 14W. |
| Light running speeds (rack disconnected) | .. | .. | .. | .. | .. | 46 to 52 r.p.m. (normal speed), 60 to 70 r.p.m. (fast speed). |
| Light running current | .. | .. | .. | .. | .. | 1.5 amps. (normal speed), 2 amps. (fast speed). |
| Brush spring pressure | .. | .. | .. | .. | .. | 5 to 7 oz. (140 to 200 gm.). |
| Minimum brush length | .. | .. | .. | .. | .. | $\frac{1}{8}$ in. (4.8 mm.). |
| Armature end-float | .. | .. | .. | .. | .. | .002 to .008 in. (.05 to .2 mm.). |
| Maximum pull to move rack in tube | .. | .. | .. | .. | .. | 6 lb. (2.7 kg.). |
| Windscreen wiper arm spring pressure | .. | .. | .. | .. | .. | 7 to 9 oz. (200 to 255 gm.). |

GENERAL DIMENSIONS

| | | | | | | |
|------------------------|----|----|----|----|----|---------------------------------------|
| Wheelbase: Saloon | .. | .. | .. | .. | .. | 6 ft. 8 $\frac{1}{2}$ in. (2.036 m.). |
| Estate | .. | .. | .. | .. | .. | 7 ft. 0 $\frac{1}{2}$ in. (2.138 m.). |
| Overall length: Saloon | .. | .. | .. | .. | .. | 10 ft. 4 $\frac{3}{8}$ in. (3.16 m.). |
| Estate | .. | .. | .. | .. | .. | 11 ft. 2 in. (3.4 m.). |
| Overall width | .. | .. | .. | .. | .. | 4 ft. 7 $\frac{1}{2}$ in. (1.41 m.). |
| Overall height: Saloon | .. | .. | .. | .. | .. | 4 ft. 5 in. (1.35 m.). |
| Estate | .. | .. | .. | .. | .. | 4 ft. 5 $\frac{1}{2}$ in. (1.36 m.). |
| Ground clearance.. | .. | .. | .. | .. | .. | 6 $\frac{1}{2}$ in. (15.63 mm.). |
| Turning circle: Saloon | .. | .. | .. | .. | .. | 28 ft. 6 in. (8.55 m.). |
| Estate | .. | .. | .. | .. | .. | 29 ft. (8.84 m.). |

WEIGHTS

| | | | | | | |
|-------------------------------|----|----|----|----|----|----------------------------|
| Kerbside weight: Saloon.. | .. | .. | .. | .. | .. | 1406 lb. (638 kg.) approx. |
| Estate | .. | .. | .. | .. | .. | 1514 lb. (686 kg.) approx. |
| Maximum towing weight: Saloon | .. | .. | .. | .. | .. | 8 cwt. (406.4 kg.) |
| Estate | .. | .. | .. | .. | .. | 6 cwt. (304.7 kg.) |

(suitable for 1 in 8 gradient in bottom gear).

CAPACITIES

| | | | | | | |
|--|----|----|----|----|----|--|
| Transmission casing (including filter) | .. | .. | .. | .. | .. | 8 $\frac{1}{2}$ pints (10.2 U.S. pints, 4.83 litres). |
| Cooling system | .. | .. | .. | .. | .. | 5 $\frac{1}{4}$ pints (6.3 U.S. pints, 3 litres). |
| With heater | .. | .. | .. | .. | .. | 6 $\frac{1}{4}$ pints (7.5 U.S. pints, 3.55 litres). |
| Fuel tank: Saloon | .. | .. | .. | .. | .. | 5 $\frac{1}{2}$ gallons (6.6 U.S. gallons, 25 litres). |
| Estate | .. | .. | .. | .. | .. | 6 gallons (7.2 U.S. gallons, 27.3 litres). |

TORQUE TIGHTENING FIGURES

Alternator (type 16ACR)

| | | | | | | |
|-----------|----|----|----|----|----|---------------------------------------|
| Shaft nut | .. | .. | .. | .. | .. | 25 to 30 lb. ft. (3.5 to 4.2 kg. m.). |
|-----------|----|----|----|----|----|---------------------------------------|

Refer to page General Data 6 for all other Torque figures.

GENERAL DATA

MINI 1275 GT

ENGINE

| | | | |
|-------------------------|---------|----|---|
| Type | | .. | 12H. |
| Number of cylinders | | .. | 4. |
| Bore | | .. | 2.78 in. (70.61 mm.). |
| Stroke | | .. | 3.2 in. (81.28 mm.). |
| Capacity | | .. | 77.8 cu. in. (1274.86 c.c.). |
| Firing order | | .. | 1, 3, 4, 2. |
| Valve operation | | .. | Overhead by push-rod. |
| Compression ratio: H.C. | | .. | 8.8 : 1. |
| L.C. | | .. | 8 : 1. |
| B.M.E.P.: H.C. | | .. | 134 lb./sq. in. (9.4 kg./cm. ²) at 3,500 r.p.m. |
| Torque: H.C. | | .. | 69 lb. ft. at 3,500 r.p.m. |
| Oversize bore: 1st | | .. | .010 in. (.25 mm.). |
| Max. | | .. | .020 in. (.51 mm.). |

Crankshaft

| | | | |
|---------------------------|---------|----|---|
| Main journal diameter | | .. | 2.0005 to 2.0010 in. (50.81 to 50.82 mm.). |
| Crankpin journal diameter | | .. | 1.7504 to 1.7509 in. (44.45 to 44.47 mm.). |
| Crankshaft end thrust | | .. | Taken in thrust washers at centre main bearing. |
| Crankshaft end-float | | .. | .002 to .003 in. (.05 to .07 mm.). |

Main bearings

| | | | |
|-----------------------|---------|----|---|
| Number and type | | .. | Three thin-wall; split shells copper-lead-indium. |
| Material | | .. | VP3, lead-indium at NFM/3B. |
| Length | | .. | .975 to .985 in. (24.76 to 25.02 mm.). |
| Diametrical clearance | | .. | .001 to .0027 in. (.025 to .07 mm.). |
| Undersizes | | .. | .020 in. (.51 mm.) and .040 in. (1.02 mm.). |

Connecting rods

| | | | |
|------------------------|---------|----|--|
| Type | | .. | Horizontally split lug end, plain small end. |
| Length between centres | | .. | 5.748 to 5.792 in. (21.36 to 21.59 mm.). |

Big-end bearings

| | | | |
|-----------------------|---------|----|---|
| Type and material | | .. | Thin-wall; steel-backed, copper-lead-indium plated. |
| Length | | .. | .840 to .850 in. (21.33 to 21.59 mm.). |
| Diametrical clearance | | .. | .001 to .0025 in. (.02 to .06 mm.). |
| End-float of crankpin | | .. | .006 to .010 in. (.15 to .25 mm.). |

Pistons

| | | | |
|---|---------|----|--|
| Type | | .. | Aluminium, solid skirt, dished crown. |
| Clearance in cylinder: Top of skirt | | .. | .0029 to .0037 in. (.07 to .09 mm.). |
| Bottom of skirt | | .. | .0015 to .0021 in. (.04 to .05 mm.). |
| Number of rings | | .. | 4 (3 compression, 1 oil control). |
| Width of ring grooves: Top, second, third | | .. | .0484 to .0494 in. (1.23 to 1.22 mm.). |
| Oil control | | .. | .1578 to .1588 in. (4.01 to 4.03 mm.). |
| Gudgeon pin base | | .. | .8125 to .8129 in. (20.64 to 20.65 mm.). |

GENERAL DATA

MINI 1275 GT—continued

Piston rings

| | | | | | | |
|-------------------------------|----|----|----|----|----|--|
| Compression: Type: Top | .. | .. | .. | .. | .. | Internally chamfered chrome. |
| Second and third | .. | .. | .. | .. | .. | Tapered cast iron. |
| Width Top | .. | .. | .. | .. | .. | } .0615 to .0625 in. (1.57 to 1.60 mm.). |
| Second and Third | .. | .. | .. | .. | .. | |
| Fitted gap: Top | .. | .. | .. | .. | .. | .011 to .016 in. (.28 to .05 mm.). |
| Second and third | .. | .. | .. | .. | .. | .008 to .013 in. (.20 to .33 mm.). |
| Ring to groove clearance: Top | .. | .. | .. | .. | .. | } .0015 to .0035 in. (.04 to .09 mm.). |
| Second and third | .. | .. | .. | .. | .. | |
| Oil control: | | | | | | |
| Type | .. | .. | .. | .. | .. | Duaflex 61. |
| Fitted gap: Rails | .. | .. | .. | .. | .. | } .012 to .028 in. (.30 to .70 mm.). |
| Side spring | .. | .. | .. | .. | .. | |

Gudgeon pin

| | | | | | | |
|-----------------------|----|----|----|----|----|---|
| Type | .. | .. | .. | .. | .. | Pressed in connecting rod. |
| Fit in piston | .. | .. | .. | .. | .. | Hand push fit. |
| Diameter (outer) | .. | .. | .. | .. | .. | .8123 to .8125 in. (20.63 to 20.64 mm.). |
| Fit to connecting rod | .. | .. | .. | .. | .. | .0008 to .0015 in. (.02 to .04 mm.) interference. |

Camshaft

| | | | | | | |
|--------------------------------|----|----|----|----|----|---|
| Journal diameters: Front | .. | .. | .. | .. | .. | 1.6655 to 1.6660 in. (42.304 to 42.316 mm.). |
| Centre | .. | .. | .. | .. | .. | 1.62275 to 1.62325 in. (41.218 to 41.231 mm.). |
| Rear | .. | .. | .. | .. | .. | 1.37275 to 1.37350 in. (34.866 to 34.889 mm.). |
| Bearing liner inside diameter: | | | | | | |
| Un-reamed after fitting: Front | .. | .. | .. | .. | .. | 1.652 in. (41.98 mm.). |
| Centre | .. | .. | .. | .. | .. | 1.61 in. (40.89 mm.). |
| Rear | .. | .. | .. | .. | .. | 1.36 in. (34.52 mm.). |
| Reamed after fitting: Front | .. | .. | .. | .. | .. | 1.6670 to 1.6675 in. (42.34 to 42.35 mm.). |
| Centre | .. | .. | .. | .. | .. | 1.62425 to 1.62475 in. (41.25 to 41.37 mm.). |
| Rear | .. | .. | .. | .. | .. | 1.3745 to 1.3750 in. (34.91 to 34.92 mm.). |
| Bearings: Type | .. | .. | .. | .. | .. | White-metal-lined, steel-backed. |
| Diametrical clearance | .. | .. | .. | .. | .. | .001 to .002 in. (.02 to .05 mm.). |
| End-thrust | .. | .. | .. | .. | .. | Taken on locating plate. |
| End-float | .. | .. | .. | .. | .. | .003 to .007 in. (.07 to .18 mm.). |
| Cam lift | .. | .. | .. | .. | .. | .318 in. (8.07 mm.). |
| Drive | .. | .. | .. | .. | .. | Duplex chain and gear from crankshaft. |
| Timing chain | .. | .. | .. | .. | .. | $\frac{3}{8}$ in. (9.52 mm.) pitch \times 52 pitches. |

Tappets

| | | | | | | |
|------------------|----|----|----|----|----|--|
| Type | .. | .. | .. | .. | .. | Bucket. |
| Outside diameter | .. | .. | .. | .. | .. | .81125 to .81175 in. (20.60 to 20.62 mm.). |
| Length | .. | .. | .. | .. | .. | 1.495 to 1.505 in. (37.97 to 38.23 mm.). |

Rocker gear

| | | | | | | |
|------------------------|----|----|----|----|----|--|
| Rocker shaft: Diameter | .. | .. | .. | .. | .. | .5615 to .5625 in. (14.26 to 14.29 mm.). |
| Rocker arm: Bore | .. | .. | .. | .. | .. | .686 to .687 in. (17.45 mm.). |
| Bush inside diameter | .. | .. | .. | .. | .. | .5630 to .5635 in. (14.3 to 14.31 mm.). |

GENERAL DATA

MINI 1275 GT—continued

Valves

| | | |
|--|---------|--|
| Seat angle: Inlet and exhaust | | 45°. |
| Head diameter: Inlet | | 1.307 to 1.312 in. (33.2 to 33.21 mm.). |
| Exhaust | | 1.1515 to 1.1565 in. (29.24 to 29.37 mm.). |
| Stem diameter: Inlet | | .2793 to .2798 in. (7.09 to 7.11 mm.). |
| Exhaust | | .2788 to .2793 in. (7.08 to 7.09 mm.). |
| Stem to guide clearance: Inlet and exhaust | | .0015 to .0025 in. (.04 to .08 mm.). |
| Valve lift: Inlet and exhaust | | .318 in. (8.07 mm.). |

Valve guides

| | | |
|-----------------------------------|---------|-------------------------|
| Length: Inlet | | 1.6875 in. (42.87 mm.). |
| Exhaust | | 1.8437 in. (46.83 mm.). |
| Fitted height above seat: Exhaust | | .540 in. (13.72 mm.). |
| Inlet | | |

Valve springs

| | | |
|-----------------------|---------|-------------------------|
| Free length | | 1.95 in. (49.13 mm.). |
| Fitted length | | 1.383 in. (34.715 mm.). |
| Load at fitted length | | 79.5 lb. (36.03 kg.). |
| Load at top of lift | | 124 lb. (56.3 kg.). |
| No. of working coils | | 4½. |

Valve timing

| | | |
|---------------------------|---------|---------------------------|
| Timing marks | | Dimples on timing gears. |
| Rocker clearance: Running | | .012 in. (.305 mm.) cold. |
| Timing | | .021 in. (.533 mm.). |
| Inlet valve: Opens | | 5° B.T.D.C. |
| Closes | | 45° B.B.D.C. |
| Exhaust valve: Opens | | 51° B.B.D.C. |
| Closes | | 21° A.T.D.C. |

ENGINE LUBRICATION SYSTEM

Oil pump

| | | |
|----------------------------------|---------|---|
| Type | | Internal gear, splined drive from camshaft. |
| Oil pressure relief valve | | 50 lb./sq. in. (5.3 kg. cm. ²). |
| Relief valve spring: Free length | | 2.86 in. (72.64 mm.). |
| Fitted length | | 2.156 in. (54.77 mm.). |
| Load at fitted length | | 13 to 14 lb. (5.90 to 6.35 kg.). |

Oil filter

| | | |
|----------|---------|-------------------------------------|
| Type | | Full-flow type, renewable element. |
| Capacity | | 1 pint (1.2 U.S. pints, .57 litre). |

System pressure

| | | |
|---------|---------|---|
| Running | | 70 lb./sq. in. (4.92 kg. cm. ²) approx. |
| Idling | | 15 lb./sq. in. (1.05 kg. cm. ²) approx. |

GENERAL DATA

MINI 1275 GT—continued

IGNITION SYSTEM

| | | |
|----------------|---|-------------------------|
| Coil | } | Refer to 'TUNING DATA'. |
| Distributor | | |
| Sparking plugs | | |

COOLING SYSTEM

| | |
|----------------------------|---|
| Thermostat settings | |
| Standard | 82° C. (180° F.). |
| Hot countries | 74° C. (165° F.). |
| Cold countries | 88° C. (190° F.). |
| Pressure cap | 13 lb./sq. in. (·91 kg./cm. ²). |

FUEL SYSTEM

Carburettor refer to 'TUNING DATA'.

Air cleaner

| | |
|--------------|--|
| Type | Paper element with warm/cold air intake and silencer tube. |
|--------------|--|

Fuel pump

| | |
|-------------------------|--|
| Make/type | S.U. mechanical; AUF 700 (AUF 705 model). |
| Suction (min.) | 6 in. (152 mm.) Hg. |
| Pressure (min.) | 3 lb./sq. in. (·21 kg./cm. ²). |

CLUTCH

| | |
|--------------------------------------|---|
| Make and type | Borg & Beck diaphragm type. |
| Clutch plate diameter | 7½ in. (180·9 mm.). |
| Facing material | Wound yarn. |
| Diaphragm-spring colour code | Green/Blue. |
| Clutch fluid | Lockheed Clutch and Brake Fluid (Series 329). |

TRANSMISSION

Gearbox

| | |
|--|----------------------------|
| Number of forward speeds | 4. |
| Synchromesh | All forward gears. |
| Ratios: Top | 1·00 : 1. |
| Third | 1·35 : 1. |
| Second | 2·07 : 1. |
| First | 3·30 : 1. |
| Reverse | 3·35 : 1. |
| Overall ratios: Top | 3·65 : 1. |
| Third | 4·93 : 1. |
| Second | 7·56 : 1. |
| First | 12·04 : 1. |
| Reverse | 12·21 : 1. |
| Road speed at 1,000 r.p.m. in top gear | 15 m.p.h. (24·14 km.p.h.). |
| Speedometer gear ratio | 4/16. |

Final drive

| | |
|---------------|---------------------------------|
| Type | Helical gears and differential. |
| Ratio | 3·65 : 1 (17/62). |

GENERAL DATA

MINI 1275 GT—continued

DRIVE SHAFTS

| | |
|-------------------------------|--|
| Make | Hardy Spicer. |
| Type of shaft | Solid. |
| Joint at wheel end | Constant velocity. |
| Coupling at inner end | Needle roller universal joint and sliding spline with flange coupling. |

STEERING

| | |
|---|--|
| Type | Rack and pinion. |
| Steering-wheel turns—lock to lock | 2.7. |
| Steering-wheel diameter | 15.0 in. (380 mm.). |
| Front wheel alignment | $\frac{1}{8}$ in. (1.6 mm.) toe-out unladen. |

SUSPENSION

| | |
|-----------------------------------|---|
| Type | Hydrolastic suspension. |
| Fluid capacity | 4 pints (5 U.S. pints, 2.27 litres), approx. |
| *Fluid pressure (unladen) | 292 lb./sq. in. (20.6 kg./cm. ²), approx. |
| Trim height: Front | $13 \pm \frac{3}{8}$ in. (330 ± 9.5 mm.). |
| Rear | $13 \frac{1}{2} \pm \frac{3}{8}$ in. (343 ± 9.5 mm.). |

* Adjust to trim height.

BRAKES

| | |
|---------------------|---|
| Type | Lockheed hydraulic with vacuum servo. |
| Servo unit | Lockheed (Type 6). |
| Brake fluid | Lockheed Clutch and Brake Fluid (Series 329). |

Front

| | |
|-------------------------------|---|
| Type | Disc. |
| Disc diameter | $7 \frac{1}{2}$ in. (190.5 mm.). |
| Pad material | Mintex M78 (Red/green/red/green/red). |
| Pad area (total) | 17.3 sq. in. (111.4 cm. ²). |
| Swept area (total) | 122 sq. in. (787 cm. ²). |
| Minimum pad thickness | $\frac{1}{8}$ in. (1.6 mm.). |

Rear

| | |
|---------------------------|--|
| Drum size | 7 in. (17.8 cm.) diameter. |
| Lining dimensions | 6.75 × 1.5 in. (17.4 × 3.8 cm.). |
| Lining area total | 40.5 sq. in. (261.29 cm. ²). |
| Lining material | Don 202. |

WHEELS

| | |
|--------------|-------------------------------|
| Type | Pressed steel disc (Rostyle). |
| Size | 4.5J × 10. |

TYRES

| | |
|---|--|
| Size | 145—10 Radial ply (tubed). |
| Pressures all conditions: Front | 28 lb./sq. in. (1.97 kg./cm. ²). |
| Rear | 26 lb./sq. in. (1.83 kg./cm. ²). |

GENERAL DATA

MINI 1275 GT—continued

ELECTRICAL EQUIPMENT

| | |
|---|---|
| System | 12-volt, negative earth. |
| Charging system | Compensated voltage control. |
| Battery | Lucas C9 or CZ9. |
| Capacity | 43 amp.-hr. at 20-hr. rate. |
| Dynamo | Lucas C40. |
| Maximum output | 22 amps. at 2,250 r.p.m. |
| Cut-in speed | 1,450 r.p.m. at 13.5 volts. |
| Control box | Lucas RB106/2. |
| Cut-out: Cut-in voltage | 12.7 to 13.3. |
| Drop-off voltage | 8.5 to 11.0. |
| Reverse current | 5.0 amps. (max.). |
| Regulator (at 3,000 r.p.m. dynamo speed): | |
| Open-circuit setting at 20° C. (68° F.) | 16.0 to 16.6 volts. |
| For ambient temperatures other than 20° C. (68° F.) the following allowances should be made to the above setting: | |
| For every 10° C. (18° F.) above 20° C. (68° F.) subtract | |
| -1 volt. | |
| For every 10° C. (18° F.) below 20° C. (68° F.) add | |
| -1 volt. | |
| Starter motor | Lucas M35G or M35J. |
| M35G Type | |
| Brush spring tension | 15 to 25 oz. (425 to 709 gm.). |
| M35J Type | |
| Brush spring tension | 28 oz. (794 gm.). |
| Light running current | 65 amperes at 8,000–10,000 r.p.m. |
| Lock torque | 7 lb. ft. (.97 kg. m.) with 350–375 amps. |
| Alternator | Lucas 16ACR. |
| Nominal output | 34 amps. at 6,000 r.p.m. (engine—2,800 r.p.m.). |
| Nominal system voltage | 14.2 volts at 20% nominal output. |
| Maximum continuous speed | 12,500 r.p.m. |
| Resistance of rotor winding at 20° C. (68° F.) | 4.33 ohms ±5%. |
| Brush spring tension | 7 to 10 oz. (198 to 283 gm.). |
| Windscreen wiper | Lucas 14W. |
| Light running speeds (rack disconnected) | 46 to 52 r.p.m. (normal speed), 60 to 70 r.p.m. (fast speed). |
| Light running current | 1.5 amps. (normal speed), 2 amps. (fast speed). |
| Brush spring pressure | 5 to 7 oz. (140 to 200 gm.). |
| Minimum brush length | $\frac{7}{16}$ in. (4.8 mm.). |
| Armature end-float | .002 to .008 in. (.05 to .2 mm.). |
| Maximum pull to move rack in tube | 6 lb. (2.7 kg.). |
| Windscreen wiper arm spring pressure | 7 to 9 oz. (200 to 255 gm.). |

GENERAL DIMENSIONS

| | |
|--------------------------|---------------------------------------|
| Wheelbase | 6 ft. 8 $\frac{3}{8}$ in. (2.036 m.). |
| Overall length | 10 ft. 4 $\frac{1}{4}$ in. (3.16 m.). |
| Overall width | 4 ft. 7 $\frac{1}{2}$ in. (1.41 m.). |
| Overall height | 4 ft. 5 in. (1.35 m.). |
| Ground clearance | 6 in. (152.4 mm.). |
| Turning circle | 28 ft. 6 in. (8.55 m.). |
| Track: Front | 48 $\frac{1}{2}$ in. (1.23 m.). |
| Rear | 47 $\frac{1}{8}$ in. (1.20 m.). |

GENERAL DATA

MINI 1275 GT—continued

WEIGHTS

| | |
|--|-----------------------------|
| Kerbside weight | 1,555 lb. (707 kg.) approx. |
| Maximum permissible towing weight (suitable for 1 in 8 gradient in bottom gear): | 8 cwt. (406.4 kg.). |

WEIGHT OF COMPONENTS

| | |
|--|--------------------|
| Engine and transmission assembly | 339 lb. (154 kg.). |
|--|--------------------|

CAPACITIES

| | |
|--|---|
| Transmission casing (including filter) | 8½ pints (10.2 U.S. pints, 4.83 litres). |
| Cooling system | 5¼ pints (6.3 U.S. pints, 3 litres). |
| With heater | 6¼ pints (7.5 U.S. pints, 3.55 litres). |
| Fuel tank | 5½ gallons (6.6 U.S. gallons, 25 litres). |

TORQUE TIGHTENING FIGURES

| Engine | <i>lb. ft.</i> | <i>kg. m.</i> |
|--|----------------|---------------|
| Cylinder head nuts | 50 | 7 |
| Connecting rod bolt nuts (including multi-sided type nuts—oiled) | 31 to 35 | 4.3 to 4.8 |
| Alternator (type 16ACR) | | |
| Shaft nut | 25 to 30 | 3.5 to 4.2 |
| Brakes | | |
| Calliper retaining bolts | 35 to 40 | 4.8 to 5.5 |
| Suspension and steering | | |
| Drive shaft nut | 150 | 20.7 |
| Steering lever ball joint | 25 to 30 | 3.5 to 4.2 |

Refer to page General Data 6 for all other Torque figures.



ENGINE TUNING DATA

Model: MINI Mk. I—Saloon and variants
 —Moke
 MINI Mk. II—Saloon and variants
 MINI 850—Saloon and variants

(848 c.c.)

Year: 1959–67
 1965–69
 1967–69
 1969 on

ENGINE

| | | | |
|-----------------------------|---------|---|--|
| Type: Mk. I and II models | | 8AM. | |
| 850 models | | 85H. | |
| Capacity | | 848 cc. (51.7 cu. in.). | |
| Compression ratio | | 8.3 : 1. | |
| Firing order | | 1, 3, 4, 2. | |
| Compression pressure | | 150 lb./sq. in. (10.5 kg./cm. ²). | |
| Idling speed | | 500 r.p.m. | |
| Fast idle speed | | 900 r.p.m. | |
| Valve rocker clearance | | .012 in. (.305 mm.) (cold). | |
| Timing marks | | Dimples on timing wheels, marks on flywheel. | |
| Ignition timing: | | <i>Premium fuel distributor</i> | <i>Regular (commercial) fuel distributor</i> |
| Static | | T.D.C. | 7° B.T.D.C. |
| *Stroboscopic at 600 r.p.m. | | 3° B.T.D.C. | 10° B.T.D.C. |

* Crankshaft degrees and r.p.m.

DISTRIBUTOR

| | | | |
|-----------------------|---------|---|--|
| Make/type: Early type | | Lucas DM2. | |
| Later type | | Lucas 25D4. | |
| Contact breaker gap | | .014 to .016 in. (.35 to .40 mm.). | |
| Rotation of rotor | | Anti-clockwise. | |
| Dwell angle | | 60° ± 3°. | |
| Condenser capacity | | .18 to .24 mF. | |
| Serial number | | 40768, 41026. | 40767, 41007. |
| Centrifugal advance | | <i>Premium fuel distributor</i> | <i>Regular (commercial) fuel distributor</i> |
| Decelerating check*† | | 30° to 34° at 3,400 r.p.m. 24° to 28° at 2,500 r.p.m. 16° to 20° at 1,300 r.p.m. 9° to 15° at 900 r.p.m. 1° to 7° at 700 r.p.m. | 22° to 26° at 5,000 r.p.m. 15° to 19° at 3,900 r.p.m. 1° to 5° at 1,700 r.p.m. |
| No advance below | | 500 r.p.m. | 850 r.p.m. |
| Vacuum advance | | | |
| Starts | | 7 in. (17.7 cm.) Hg. | 5 in. (12.7 cm.) Hg. |
| Finishes† | | 10° at 13 in. (33 cm.) Hg. | 16° at 11 in. (27.9 cm.) Hg. |

* Vacuum pipe disconnected.

† Crankshaft degrees and r.p.m.

SPARKING PLUGS

| | | |
|------|---------|----------------------|
| Make | | Champion. |
| Type | | N5 or N9Y. |
| Gap | | .025 in. (.625 mm.). |

IGNITION COIL

| | | |
|---------------------------------------|---------|-------------------------|
| Make/type | | Lucas LA12. |
| Primary resistance at 20° C. (68° F.) | | 3.2 to 3.4 ohms (cold). |
| Consumption—ignition on | | 3.9 amps. |

CARBURETTER

| | | |
|------------------|---------|----------------------|
| Make/type | | S.U. Type HS2. |
| Piston spring | | Red. |
| Jet size | | .090 in. (2.29 mm.). |
| Needle: Standard | | EB. |
| Rich | | M. |
| Weak | | GG. |

ENGINE TUNING DATA

Model: MINI Mk. II—Saloon and variants
MINI 1000—Saloon

(998 c.c.)

Year: 1967-69
1969 on

ENGINE

| | | |
|-------------------------------|---------|---|
| Type | | 99H. |
| Capacity | | 998 c.c. (60.96 cu. in.). |
| Compression ratio | | 8.3 : 1. |
| Firing order | | 1, 3, 4, 2. |
| Compression pressure | | 150 lb./sq. in. (10.5 kg./cm. ²). |
| Idling speed | | 500 r.p.m. |
| Fast idle speed | | 900 r.p.m. |
| Ignition timing: | | |
| Static | | 5° B.T.D.C. |
| *Stroboscopic at 600 r.p.m. | | 8° B.T.D.C. |
| Timing marks | | Dimples on timing wheels, marks on flywheel. |
| Valve rocker clearance (cold) | | .012 in. (.305 mm.) (cold). |

* Crankshaft degrees and r.p.m.

DISTRIBUTOR

| | | |
|---------------------|---------|------------------------------------|
| Make/type | | Lucas 25D4. |
| Rotation of rotor | | Anti-clockwise. |
| Dwell angle | | 60°±3°. |
| Contact breaker gap | | .014 to .016 in. (.35 to .40 mm.). |
| Condenser capacity | | .18 to .24 mF. |
| Serial No. | | 40931, 41030. |

Centrifugal advance

| | | |
|----------------------|---------|--|
| Decelerating check*† | | 22° to 26° at 5,000 r.p.m. 16° to 20° at 3,400 r.p.m. 9° to 13° at 1,600 r.p.m. 6° to 10° at 1,300 r.p.m. 0° to 4° at 900 r.p.m. |
| No advance below | | 600 r.p.m. |

Vacuum advance

| | | |
|-----------|---------|------------------------------|
| Starts | | 5 in. (12.7 cm.) Hg. |
| Finishes† | | 14° at 11 in. (27.9 cm.) Hg. |

* Vacuum pipe disconnected.

† Crankshaft degrees and r.p.m.

SPARKING PLUGS

| | | |
|------|---------|----------------------|
| Make | | Champion. |
| Type | | N5 or N9Y. |
| Gap | | .025 in. (.625 mm.). |

IGNITION COIL

| | | |
|---------------------------------------|---------|-------------------------|
| Make/type | | Lucas LA12. |
| Primary resistance at 20° C. (68° F.) | | 3.2 to 3.4 ohms (cold). |
| Consumption—ignition on | | 3.9 amps. |

CARBURETTER

| | | |
|------------------|---------|----------------------|
| Make/type | | S.U. Type HS2. |
| Piston spring | | Red. |
| Jet size | | .090 in. (2.29 mm.). |
| Needle: Standard | | GX. |
| Rich | | M. |
| Weak | | GG. |

ENGINE TUNING DATA

Model: MINI Mk. I and II AUTOMATIC (848 c.c.)

Year: 1965-69

ENGINE

| | | |
|-------------------------------|---------|---|
| Type | | 8AH. |
| Capacity | | 848 c.c. (51.7 cu. in.). |
| Compression ratio | | 8.9 : 1. |
| Firing order | | 1, 3, 4, 2. |
| Compression pressure | | 150 lb./sq. in. (10.5 kg./cm. ²). |
| Idling speed | | 650 r.p.m. |
| Fast idle speed | | 1,050 r.p.m. |
| Ignition timing: | | |
| Static | | 3° B.T.D.C. |
| *Stroboscopic at 600 r.p.m. | | 6° B.T.D.C. |
| Timing marks | | Dimples on timing wheels, marks on converter. |
| Valve rocker clearance (cold) | | .012 in. (.305 mm.) (cold). |

* Crankshaft degrees and r.p.m.

DISTRIBUTOR

| | | |
|---------------------|---------|------------------------------------|
| Make/type | | Lucas 25D4. |
| Rotation of rotor | | Anti-clockwise. |
| Dwell angle | | 60° ± 3°. |
| Contact breaker gap | | .014 to .016 in. (.35 to .40 mm.). |
| Condenser capacity | | .18 to .24 mF. |
| Serial No. | | 41134, 41242, 41251. |

Centrifugal advance

| | | |
|----------------------|---------|--|
| Decelerating check*† | | 26° to 30° at 5,500 r.p.m. 24° to 28° at 4,800 r.p.m. 15° to 19° at 1,800 r.p.m. 12° to 16° at 1,600 r.p.m. 0° to 4° at 800 r.p.m. |
|----------------------|---------|--|

No advance below 600 r.p.m.

Vacuum advance

| | | |
|-----------|---------|------------------------------|
| Starts | | 3 in. (7.62 cm.) Hg. |
| Finishes† | | 18° at 15 in. (38.1 cm.) Hg. |

* Vacuum pipe disconnected.

† Crankshaft degrees and r.p.m.

SPARKING PLUGS

| | | |
|------|---------|----------------------|
| Make | | Champion. |
| Type | | N5. |
| Gap | | .025 in. (.625 mm.). |

IGNITION COIL

| | | |
|---------------------------------------|---------|-------------------------|
| Make/type | | Lucas LA12. |
| Primary resistance at 20° C. (68° F.) | | 3.2 to 3.4 ohms (cold). |
| Consumption—ignition on | | 3.9 amps. |

CARBURETTER

| | | |
|------------------|---------|----------------------|
| Make/type | | S.U. Type HS4. |
| Piston spring | | Red. |
| Jet size | | .090 in. (2.29 mm.). |
| Needle: Standard | | AN. |
| Rich | | H6. |
| Weak | | EB. |

ENGINE TUNING DATA

Model: MINI Mk. II AUTOMATIC (998 c.c.)
MINI 1000 and CLUBMAN AUTOMATIC

Year: 1967-69
1969 on

ENGINE

| | | |
|-------------------------------|---------|---|
| Type | | 9AG, 99H. |
| Capacity | | 998 c.c. (60.96 cu. in.). |
| Compression ratio | | 8.9 : 1. |
| Firing order | | 1, 3, 4, 2. |
| Compression pressure | | — |
| Idling speed | | 650 r.p.m. |
| Fast idle speed | | 1,050 r.p.m. |
| Ignition timing: | | |
| Static | | 4° B.T.D.C. |
| *Stroboscopic at 600 r.p.m. | | 6° B.T.D.C. |
| Timing marks | | Dimples on timing wheels, marks on converter. |
| Valve rocker clearance (cold) | | .012 in. (.305 mm.) (cold). |

* Crankshaft degrees and r.p.m.

DISTRIBUTOR

| | | |
|---------------------|---------|------------------------------------|
| Make/type | | Lucas 25D4. |
| Rotation of rotor | | Anti-clockwise. |
| Dwell angle | | 60° ± 3°. |
| Contact breaker gap | | .014 to .016 in. (.35 to .40 mm.). |
| Condenser capacity | | .18 to .24 mF. |
| Serial No. | | 41134, 41242. |

Centrifugal advance

| | | |
|----------------------|---------|--|
| Decelerating check*† | | 26° to 30° at 5,500 r.p.m. 24° to 28° at 4,800 r.p.m. 15° to 19° at 1,800 r.p.m. 12° to 16° at 1,600 r.p.m. 0° to 4° at 800 r.p.m. |
| No advance below | | 600 r.p.m. |

Vacuum advance

| | | |
|-----------|---------|------------------------------|
| Starts | | 3 in. (7.62 cm.) Hg. |
| Finishes† | | 18° at 15 in. (38.1 cm.) Hg. |

* Vacuum pipe disconnected.

† Crankshaft degrees and r.p.m.

SPARKING PLUGS

| | | |
|------|---------|----------------------|
| Make | | Champion. |
| Type | | N5 or N9Y. |
| Gap | | .025 in. (.625 mm.). |

IGNITION COIL

| | | |
|---------------------------------------|---------|-------------------------|
| Make/type | | Lucas LA12. |
| Primary resistance at 20° C. (68° F.) | | 3.2 to 3.4 ohms (cold). |
| Consumption—ignition on | | 3.9 amps. |

CARBURETTOR

| | | |
|------------------|---------|----------------------|
| Make/type | | S.U. Type HS4. |
| Piston spring | | Red. |
| Jet size | | .090 in. (2.29 mm.). |
| Needle: Standard | | AC. |
| Rich | | M1. |
| Weak | | HA. |

ENGINE TUNING DATA

Model: MINI-COOPER (997 c.c.)

Year: 1961-64

ENGINE

| | | |
|-------------------------------------|---------|--|
| Type | | 9F. |
| Capacity | | 997 c.c. (60.87 cu. in.). |
| Compression ratio: High compression | | 9 : 1. |
| Low compression | | 8.3 : 1. |
| Firing order | | 1, 3, 4, 2. |
| Compression pressure | | — |
| Idling speed (approx.) | | 500 r.p.m. |
| Fast idle speed | | 900 r.p.m. |
| Ignition timing: | | |
| Static: High compression | | 7° B.T.D.C. |
| Low compression | | 5° B.T.D.C. |
| Stroboscopic at 600 r.p.m.: | | |
| *High compression | | 9° B.T.D.C. |
| Low compression | | 7° B.T.D.C. |
| Timing marks | | Dimples on timing wheels, marks on flywheel. |
| Valve rocker clearance | | .012 in. (.305 mm.) (cold). |

* Crankshaft degrees and r.p.m.

DISTRIBUTOR

| | | |
|----------------------|---------|---|
| Make/type | | Lucas 25D4. |
| Rotation of rotor | | Anti-clockwise. |
| Dwell angle | | 60° ± 3°. |
| Contact breaker gap | | .014 to .016 in. (.35 to .40 mm.). |
| Condenser capacity | | .18 to .24 mF. |
| Serial No. | | 40774. 40873. |
| Centrifugal advance | | |
| Decelerating check*† | | High compression Low compression |
| | | 16° to 22° at 1,600 r.p.m. 26° to 30° at 2,600 r.p.m. |
| | | 2° to 8° at 1,000 r.p.m. 21° to 25° at 2,000 r.p.m. |
| | | 0° to 3° at 800 r.p.m. 15° to 19° at 1,200 r.p.m. |
| | | 8° to 12° at 900 r.p.m. |
| | | 0° to 5° at 600 r.p.m. |
| No advance below | | 600 r.p.m. 300 r.p.m. |

Vacuum advance

| | | | |
|-----------|---------|-----------------------------|-----------------------------|
| Starts | | 3 in. (7.62 cm.) Hg. | 4 in. (10.1 cm.) Hg. |
| Finishes† | | 14° at 8 in. (20.3 cm.) Hg. | 14° at 7 in. (17.7 cm.) Hg. |

* Vacuum pipe disconnected.

† Crankshaft degrees and r.p.m.

SPARKING PLUGS

| | | |
|------|---------|----------------------|
| Make | | Champion. |
| Type | | N5. |
| Gap | | .025 in. (.625 mm.). |

IGNITION COIL

| | | |
|---------------------------------------|---------|--------------------------|
| Make/type | | Lucas HA12. |
| Primary resistance at 20° C. (68° F.) | | 3.0 to 3.4 ohms. (cold). |
| Consumption—ignition on | | 3.9 amps. |

CARBURETTORS

| | | |
|------------------|---------|----------------------|
| Make/type | | Twin S.U. Type HS2. |
| Piston spring | | Red. |
| Jet size | | .090 in. (2.29 mm.). |
| Needle: Standard | | GZ. |

ENGINE TUNING DATA

Model: MINI-COOPER (998 c.c.)

Year: 1964-69

ENGINE

| | | |
|-------------------------------|------------------|--|
| Type | | 9FA. |
| Capacity | | 998 c.c. (60.96 cu. in.). |
| Compression ratio: | High compression | 9 : 1. |
| | Low compression | 7.8 : 1. |
| Firing order | | 1, 3, 4, 2. |
| Compression pressure: | High compression | 165 lb./sq. in. (11.6 kg./cm. ²). |
| | Low compression | 150 lb./sq. in. (10.5 kg./cm. ²). |
| Idling speed | | 500 r.p.m. |
| Fast idle speed | | 900 r.p.m. |
| Ignition timing: | | <i>High compression</i> <i>Low compression</i> |
| Static | | 5° B.T.D.C. 5° B.T.D.C. |
| | | (91 to 96 octane fuel). |
| *Stroboscopic at 600 r.p.m. | | 7° B.T.D.C. 7° B.T.D.C. |
| Timing marks | | Dimples on timing wheels, marks on flywheel. |
| Valve rocker clearance (cold) | | .012 in. (.305 mm.). |

* Crankshaft degrees and r.p.m.

DISTRIBUTOR

| | | |
|----------------------|---------|---|
| Make/type | | Lucas 24D4. |
| Rotation of rotor | | Anti-clockwise. |
| Dwell angle | | 60° ± 3°. |
| Contact breaker gap | | .014 to .016 in. (.35 to .40 mm.). |
| Condenser capacity | | .18 to .24 mF. |
| Serial No. ... | | 40955, 41032. 40958, 41031. |
| Centrifugal advance | | <i>High compression</i> <i>Low compression</i> |
| Decelerating check*† | | 30° to 34° at 6,000 r.p.m. 28° to 32° at 5,500 r.p.m. |
| | | 28° to 32° at 5,400 r.p.m. 26° to 30° at 4,400 r.p.m. |
| | | 24° to 28° at 4,200 r.p.m. 22° to 26° at 2,200 r.p.m. |
| | | 18° to 22° at 2,300 r.p.m. 16° to 20° at 1,800 r.p.m. |
| | | 12° to 16° at 1,800 r.p.m. 3° to 9° at 1,000 r.p.m. |
| | | 1° to 5° at 800 r.p.m. 0° to 3° at 600 r.p.m. |
| No advance below | | 300 r.p.m. 400 r.p.m. |
| Vacuum advance | | |
| Starts | | 3 in. (7.62 cm.) Hg. 3 in. (7.62 cm.) Hg. |
| Finishes† | | 14° at 8 in. (20.32 cm.) Hg. 16° at 7 in. (17.7 cm.) Hg. |

* Vacuum pipe disconnected.

† Crankshaft degrees and r.p.m.

SPARKING PLUGS

| | | |
|------|---------|----------------------|
| Make | | Champion. |
| Type | | N5. |
| Gap | | .025 in. (.625 mm.). |

IGNITION COIL

| | | |
|---------------------------------------|---------|--------------------------|
| Make/type | | Lucas HA12. |
| Primary resistance at 20° C. (68° F.) | | 3.0 to 3.4 ohms. (cold). |
| Consumption—ignition on | | 3.9 amps. |

CARBURETTORS

| | | |
|------------------|---------|----------------------|
| Make/type | | Twin S.U. Type HS2. |
| Piston spring | | Blue. |
| Jet size | | .090 in. (2.29 mm.). |
| Needle: Standard | | GY. |
| Rich | | M. |
| Weak | | GG. |

ENGINE TUNING DATA

Model: MINI-COOPER 'S' (970 c.c. and 1071 c.c.)

Year: 1963-65

ENGINE

| | | |
|---------------------------------------|---------|--|
| Type | | 9FC, 10F. |
| Capacity: 970 c.c. | | 59.1 cu. in. |
| 1071 c.c. | | 63.35 cu. in. |
| Compression ratio: 970 c.c. | | 10 : 1. |
| 1071 c.c. | | 9.0 : 1. |
| Firing order | | 1, 3, 4, 2. |
| Compression pressure | | 190 to 200 lb./sq. in. (13.36 to 14.07 kg./cm. ²). |
| Idling speed | | 600 r.p.m. approx. |
| Fast idle speed | | 1,000 r.p.m. |
| Ignition timing: | | |
| Static: 970 c.c. | | 12° B.T.D.C. |
| 1071 c.c. | | 3° B.T.D.C. |
| Stroboscopic at 600 r.p.m.*: 970 c.c. | | 14° B.T.D.C. at 600 r.p.m. |
| 1071 c.c. | | 5° B.T.D.C. at 600 r.p.m. |
| Timing marks | | Dimples on timing wheels, marks on flywheel. |
| Valve rocker clearance: Standard | | .012 in. (.30 mm.) cold. |
| Competition | | .015 in. (.38 mm.) cold. |

* Crankshaft degrees and r.p.m.

DISTRIBUTOR

| | | |
|---------------------|---------|------------------------------------|
| Make/type | | Lucas 23D4. |
| Rotation of rotor | | Anti-clockwise. |
| Dwell angle | | 60° ± 3°. |
| Contact breaker gap | | .014 to .016 in. (.35 to .40 mm.). |
| Condenser capacity | | .18 to .24 mF. |
| Serial No. | | 40819. |

Centrifugal advance

| | | |
|----------------------|---------|----------------------------|
| Decelerating check*: | | 28° to 32° at 7,000 r.p.m. |
| | | 22° to 26° at 5,200 r.p.m. |
| | | 10° to 14° at 1,600 r.p.m. |
| | | 6° to 12° at 1,000 r.p.m. |
| | | 0° to 3° at 600 r.p.m. |
| No advance below | | 450 r.p.m. |

* Crankshaft degrees and r.p.m.

SPARKING PLUGS

| | | |
|------|---------|----------------------|
| Make | | Champion. |
| Type | | N9Y. |
| Gap | | .025 in. (.625 mm.). |

IGNITION COIL

| | | |
|---------------------------------------|---------|--------------------------|
| Make/type | | Lucas HA12. |
| Primary resistance at 20° C. (68° F.) | | 3.0 to 3.4 ohms. (cold). |
| Consumption—ignition on | | 3.9 amps. |

CARBURETTERS

| | | |
|------------------|---------|----------------------|
| Make/type | | Twin S.U. Type HS2. |
| Piston spring | | Red. |
| Jet size | | .090 in. (2.29 mm.). |
| Needle: 970 c.c. | | AN (Standard). |
| 1071 c.c. | | H6 (Standard). |

ENGINE TUNING DATA

Model: MINI-COOPER 'S' (Mk. I, II, & III)

Year: 1964/70 onwards

ENGINE

| | | | | | | | |
|----------------------------------|----|----|----|----|----|----|---|
| Type: Mk. I and II models | .. | .. | .. | .. | .. | .. | 12FA. |
| Mk. III models | .. | .. | .. | .. | .. | .. | 12H |
| Capacity | .. | .. | .. | .. | .. | .. | 1275 c.c. (77.9 cu. in.). |
| Compression ratio | .. | .. | .. | .. | .. | .. | 9.75 : 1. |
| Firing order | .. | .. | .. | .. | .. | .. | 1, 3, 4, 2. |
| Compression pressure | .. | .. | .. | .. | .. | .. | 190 to 200 lb./sq. in. (13.36 to 14.07 kg./cm. ²) at 500 r.p.m. |
| Idling speed | .. | .. | .. | .. | .. | .. | 600 r.p.m. approx. |
| Fast idle speed | .. | .. | .. | .. | .. | .. | 1,000 r.p.m. approx. |
| Ignition timing: | | | | | | | |
| Static | .. | .. | .. | .. | .. | .. | 2° B.T.D.C. |
| Stroboscopic at 600 r.p.m. | .. | .. | .. | .. | .. | .. | 4° B.T.D.C. |
| Timing marks | .. | .. | .. | .. | .. | .. | Dimples on timing wheels, marks on flywheel. |
| Valve rocker clearance: Standard | .. | .. | .. | .. | .. | .. | .012 in. (.30 mm.) cold. |
| Competition | .. | .. | .. | .. | .. | .. | .015 in. (.38 mm.) cold. |

* Crankshaft degrees and r.p.m.

DISTRIBUTOR

| | | | | | | | |
|---------------------|----|----|----|----|----|----|---|
| Make/type | .. | .. | .. | .. | .. | .. | Lucas 23D4. |
| Rotation of rotor | .. | .. | .. | .. | .. | .. | Anti-clockwise. |
| Dwell angle | .. | .. | .. | .. | .. | .. | 60° ± 3°. |
| Contact breaker gap | .. | .. | .. | .. | .. | .. | .014 to .016 in. (.35 to .40 mm.). |
| Condenser capacity | .. | .. | .. | .. | .. | .. | .18 to .24 mF. |
| Serial No. | .. | .. | .. | .. | .. | .. | 40819, 41033. |
| Centrifugal advance | | | | | | | |
| Decelerating check* | .. | .. | .. | .. | .. | .. | 28° to 32° at 7,000 r.p.m. 22° to 26° at 5,200 r.p.m. 10° to 14° at 1,600 r.p.m. 6° to 12° at 1,000 r.p.m. 0° to 3° at 600 r.p.m. |
| No advance below | .. | .. | .. | .. | .. | .. | 450 r.p.m. |

* Crankshaft degrees and r.p.m.

SPARKING PLUGS

| | | | | | | | |
|------|----|----|----|----|----|----|----------------------|
| Make | .. | .. | .. | .. | .. | .. | Champion. |
| Type | .. | .. | .. | .. | .. | .. | N9Y. |
| Gap | .. | .. | .. | .. | .. | .. | .025 in. (.625 mm.). |

IGNITION COIL

| | | | | | | | |
|---------------------------------------|----|----|----|----|----|----|--------------------------|
| Make/type | .. | .. | .. | .. | .. | .. | Lucas HA12. |
| Primary resistance at 20° C. (68° F.) | .. | .. | .. | .. | .. | .. | 3.0 to 3.4 ohms. (cold). |
| Consumption—ignition on | .. | .. | .. | .. | .. | .. | 3.9 amps. |

CARBURETTERS

| | | | | | | | |
|------------------|----|----|----|----|----|----|----------------------|
| Make/type | .. | .. | .. | .. | .. | .. | Twin S.U. Type HS2. |
| Piston spring | .. | .. | .. | .. | .. | .. | Red. |
| Jet size | .. | .. | .. | .. | .. | .. | .090 in. (2.29 mm.). |
| Needle: Standard | .. | .. | .. | .. | .. | .. | M. |
| Rich | .. | .. | .. | .. | .. | .. | AH2. |
| Weak | .. | .. | .. | .. | .. | .. | EB. |

ENGINE TUNING DATA

Model: MINI CLUBMAN

Year: 1969

ENGINE:

| | | |
|-------------------------------|---------|---|
| Type | | 99H. |
| Capacity | | 998 c.c. (60.96 cu. in.). |
| Compression ratio | | 8.3 : 1. |
| Firing order | | 1, 3, 4, 2. |
| Compression pressure | | 150 lb./sq. in. (10.5 kg./cm. ²). |
| Idling speed | | 500 r.p.m. |
| Fast idle speed | | 900 r.p.m. |
| Ignition timing: | | |
| Static | | 5° B.T.D.C. |
| *Stroboscopic at 600 r.p.m. | | 8° B.T.D.C. |
| Timing marks | | Dimples on timing wheels, marks on flywheel. |
| Valve rocker clearance (cold) | | -.012 in. (-.305 mm.) (cold). |

* Crankshaft degrees and r.p.m.

DISTRIBUTOR

| | | |
|---------------------|---------|------------------------------------|
| Make/type | | Lucas 25D4. |
| Rotation of rotor | | Anti-clockwise. |
| Dwell angle | | 60° ± 3°. |
| Contact breaker gap | | .014 to .016 in. (.35 to .40 mm.). |
| Condenser capacity | | .18 to .24 mF. |
| Serial No. | | 41030. |

Centrifugal advance

| | | |
|----------------------|---------|--|
| Decelerating check*† | | 22° to 26° at 5,000 r.p.m. 16° to 20° at 3,400 r.p.m. 9° to 13° at 1,600 r.p.m. 6° to 10° at 1,300 r.p.m. 0° to 4° at 900 r.p.m. |
| No advance below | | 600 r.p.m. |

Vacuum advance

| | | |
|-----------|---------|------------------------------|
| Starts | | 5 in. (12.7 cm.) Hg. |
| Finishes† | | 14° at 11 in. (27.9 cm.) Hg. |

* Vacuum pipe disconnected.

† Crankshaft degrees and r.p.m.

SPARKING PLUGS

| | | |
|------|---------|----------------------|
| Make | | Champion. |
| Type | | N5. |
| Gap | | .025 in. (.625 mm.). |

IGNITION COIL

| | | |
|---------------------------------------|---------|-------------------------|
| Make/type | | Lucas LA12. |
| Primary resistance at 20° C. (68° F.) | | 3.2 to 3.4 ohms (cold). |
| Consumption—ignition on | | 3.9 amps. |

CARBURETTER

| | | |
|------------------|---------|----------------------|
| Make/type | | S.U. Type HS2. |
| Piston spring | | Red. |
| Jet size | | .090 in. (2.29 mm.). |
| Needle: Standard | | GX. |
| Rich | | M. |
| Weak | | GG. |

ENGINE TUNING DATA

Model: MINI 1275 GT

Year: 1969

ENGINE

| | | | | | | | | | |
|-------------------------------|---------|---------|---------|---------|---------|---------|---------|---------|---|
| Type | | | | | | | | | 12H. |
| Capacity | | | | | | | | | 1274·86 c.c. (77·8 cu. in.). |
| Compression ratio: H.C. | | | | | | | | | 8·8 : 1. |
| | | | | | | | | | L.C. 8 : 1. |
| Firing order | | | | | | | | | 1, 3, 4, 2. |
| Compression pressure | | | | | | | | | 180 lb./sq. in. (12·6 kg./cm. ²). |
| Idling speed | | | | | | | | | 650 r.p.m. |
| Fast idle speed | | | | | | | | | 1,050 r.p.m. |
| Ignition timing: | | | | | | | | | |
| Static | | | | | | | | | 2° B.T.D.C. |
| *Stroboscopic at 600 r.p.m. | | | | | | | | | 5° B.T.D.C. |
| Timing marks | | | | | | | | | Dimples on timing wheels, marks on flywheel. |
| Valve rocker clearance (cold) | | | | | | | | | ·012 in. (·305 mm.) (cold). |

* Crankshaft degrees and r.p.m.

DISTRIBUTOR

| | | | | | | | | | |
|---------------------|---------|---------|---------|---------|---------|---------|---------|---------|------------------------------------|
| Make/type | | | | | | | | | Lucas 25D4. |
| Rotation of rotor | | | | | | | | | Anti-clockwise. |
| Dwell angle | | | | | | | | | 60° ± 3°. |
| Contact breaker gap | | | | | | | | | ·014 to ·016 in. (·35 to ·40 mm.). |
| Condenser capacity | | | | | | | | | ·18 to ·24 mF. |
| Serial No. | | | | | | | | | 41257. |

Centrifugal advance

| | | | | | | | | | |
|----------------------|---------|---------|---------|---------|---------|---------|---------|---------|---|
| Decelerating check*† | | | | | | | | | 18° to 22° at 4,000 r.p.m. 11° to 15° at 2,800 r.p.m. 6° to 10° at 2,000 r.p.m. 4° to 8° at 1,600 r.p.m. 0° to 3° at 800 r.p.m. |
| No advance below | | | | | | | | | 300 r.p.m. |

Vacuum advance

| | | | | | | | | | |
|-----------|---------|---------|---------|---------|---------|---------|---------|---------|-------------------------------------|
| Starts | | | | | | | | | 3 in. (7·62 cm.) Hg. |
| Finishes† | | | | | | | | | 18° to 22° at 10 in. (25·4 cm.) Hg. |

* Vacuum pipe disconnected.

† Crankshaft degrees and r.p.m.

SPARKING PLUGS

| | | | | | | | | | |
|------|---------|---------|---------|---------|---------|---------|---------|---------|----------------------|
| Make | | | | | | | | | Champion. |
| Type | | | | | | | | | N9Y. |
| Gap | | | | | | | | | ·025 in. (·625 mm.). |

IGNITION COIL

| | | | | | | | | | |
|---------------------------------------|---------|---------|---------|---------|---------|---------|---------|---------|-------------------------|
| Make/type | | | | | | | | | Lucas LA12. |
| Primary resistance at 20° C. (68° F.) | | | | | | | | | 3·2 to 3·4 ohms (cold). |
| Consumption—ignition on | | | | | | | | | 3·9 amps. |

CARBURETTOR

| | | | | | | | | | |
|------------------|---------|---------|---------|---------|---------|---------|---------|---------|----------------------|
| Make/type | | | | | | | | | S.U. type HS4. |
| Piston spring | | | | | | | | | Red. |
| Jet size | | | | | | | | | ·090 in. (2·29 mm.). |
| Needle: Standard | | | | | | | | | AC. |
| Rich | | | | | | | | | BQ. |
| Weak | | | | | | | | | HA. |

SECTION A

THE ENGINE

| | <i>Section</i> |
|---|----------------|
| Air cleaner | A.1 |
| †Camshaft | A.23 |
| Carburetter | A.2 |
| Crankcase closed-circuit breathing | A.27 |
| Crankshaft and main bearings | A.25 |
| †Cylinder head | A.6 |
| †Decarbonizing | A.7 |
| Distributor spindle | A.10 |
| Engine and sub-frame | A.12 |
| Engine and transmission | A.13 |
| Engine mountings | A.14 |
| Exhaust manifold | A.4 |
| Exhaust pipe | A.3 |
| Flywheel and clutch.. .. . | A.11 |
| Flywheel housing and primary gear | A.18 |
| Flywheel retaining screw thread | A.31 |
| Flywheel with diaphragm clutch | A.28 |
| Gear change remote control assembly | A.32 |
| Oil cooler (Cooper 'S') | A.29 |
| Oil pressure | A.20 |
| Oil pressure relief valve | A.21 |
| Oil pump | A.22 |
| Pistons and connecting rods | A.24 |
| Primary gear oil seal replacement | A.30 |
| †Rocker shaft | A.5 |
| †Tappets | A.9 |
| Timing cover.. .. . | A.15 |
| Timing gears and chain | A.16 |
| Transmission housing | A.19 |
| †Valve timing | A.17 |
| †Valves | A.8 |

† These operations must be followed by an exhaust emission check



THE POWER UNIT AND SYNCHROMESH TRANSMISSION ASSEMBLY

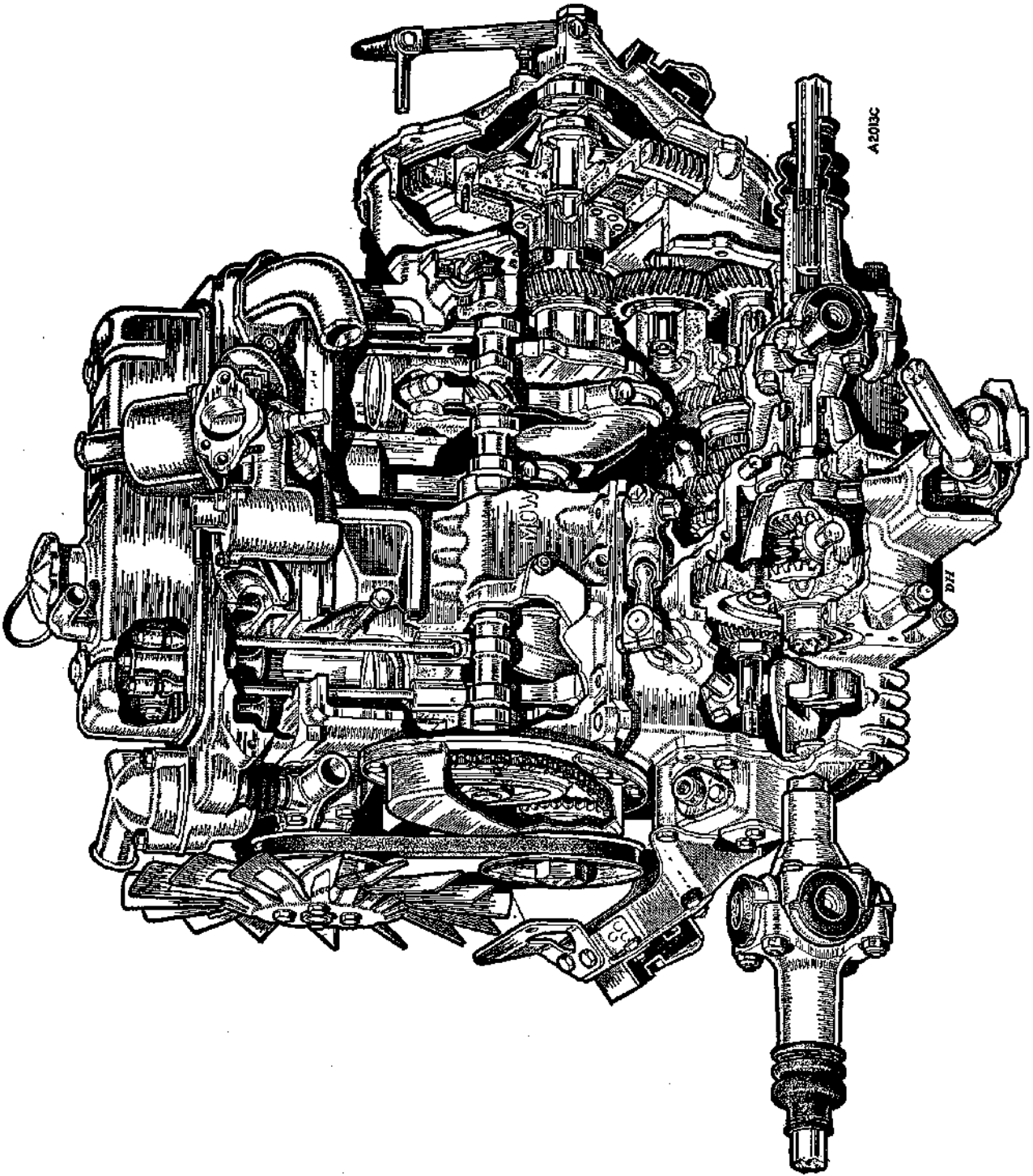

Section A.1

AIR CLEANER

Removing

- (1) Disconnect the breather hose from the rocker cover, unscrew the wing nut and lift off the cleaner.

COOPER

Removing

- (1) Disconnect the breather pipe from the rocker cover.
- (2) Remove the four securing screws to remove the gauze-type cleaner, unscrew the two wing nuts to remove the paper-element-type cleaner.

Section A.2

CARBURETTER

Removing

- (1) Remove the air cleaner.
- (2) Disconnect the mixture and throttle cables.
- (3) Disconnect the suction advance pipe.
- (4) Disconnect the fuel delivery hose.
- (5) Unscrew the two nuts and lift off the carburetter cable abutment plate and two gaskets.

When refitting, make sure the gaskets are in good condition.

COOPER

Removing

- (1) Remove the bonnet and disconnect the battery.
- (2) Disconnect the choke and throttle cables and the main flexible feed pipe.
- (3) Disconnect the interconnecting pipe support clip.
- (4) Unhook the three return springs.
- (5) Disconnect the vacuum advance pipe.
- (6) Remove the nuts and withdraw both carburetters together.

Refitting

Reverse the removing instructions and adjust the linkage as in Section D.6 (35).

Section A.3

EXHAUST PIPE

Removing

Slacken the exhaust pipe to manifold clamp and disconnect the fixing points on the gear change extension and the rear sub-frame.

Refitting

- (1) Disconnect the engine tie-rod from the cylinder block.
- (2) Assemble the exhaust pipe to the engine leaving the fixing bolts and the manifold clamp loose.
- (3) Push the engine forward to line up the tie-rod bolt holes and wedge it in position with a wooden block. If necessary, slacken the two engine to sub-frame bolts and then retighten them.
- (4) Reconnect the tie-rod.
- (5) Insert slip packings, as required, between the transmission case and the pipe bracket, and then tighten the bolt, the sub-frame fixings, and the manifold clamp.
- (6) Remove the wooden block.

COOPER

Removing

- (1) Remove the screw securing the exhaust pipe to manifold clamp from the front end of the gear change extension.
- (2) Unscrew the nuts and bolts at the intermediate and rear mountings and withdraw the pipe.

Refitting

Reverse the removing instructions.

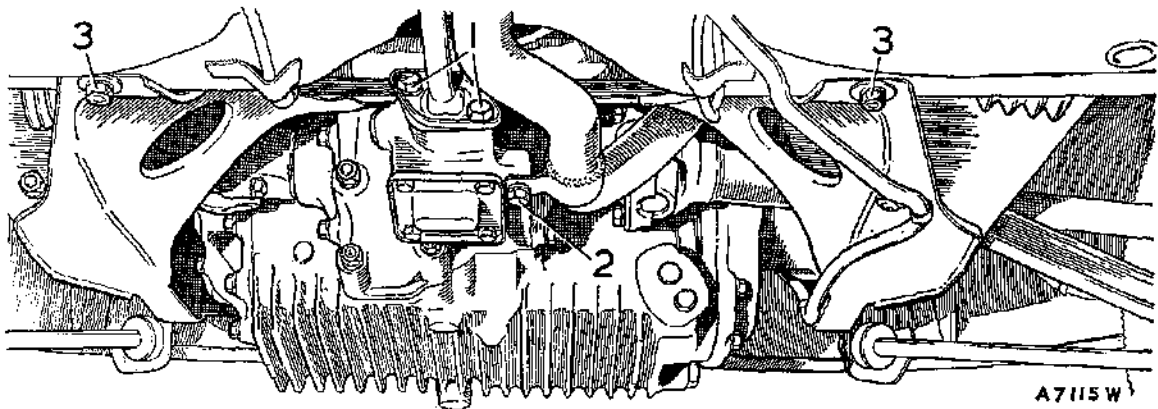

Fig. A.1

The front sub-frame and transmission casing viewed from beneath the car, showing (1) the gear change lever retaining screws, (2) the exhaust system fixing point, (3) the front sub-frame rear mounting point (four set screws)

Section A.4

EXHAUST MANIFOLD

Removing

- (1) Carry out instructions in Sections A.1 and A.2.
- (2) Slacken the pipe clamp, unscrew the six nuts and withdraw the manifold.

COOPER

- (3) Jack up the vehicle and remove the bonnet.
- (4) Remove the exhaust pipe assembly, Section A.3, and carburettors, Section A.2.
- (5) Remove the inlet manifold.
- (6) Unscrew the 'U' bolts and withdraw them from the right-hand universal joint.
- (7) Remove the right-hand wheel and disconnect the steering tie-rod.
- (8) Disconnect the top and bottom swivels, partly withdraw the hub and drive shaft.
- (9) Support the hub to avoid damage to the brake hose.
- (10) Turn the differential flange until it is upright, withdraw the exhaust manifold from the studs manoeuvre it to the right to clear the sub-frame and transmission casing and lift upwards.

Refitting

Reverse the removing instructions.

Section A.5

ROCKER SHAFT



Removing and dismantling

- (1) Remove the air cleaners (Section A.1).
- (2) Drain the cooling system (Section C.1).
- (3) Remove the rocker cover.
- (4) Slacken the rocker shaft bracket and cylinder head nuts gradually in the order shown in Fig. A.4. When the load is released remove the rocker shaft bracket nuts and the shaft and brackets.

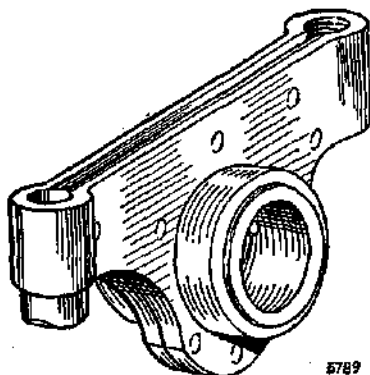

Fig. A.2

The pressed-steel type of valve rocker

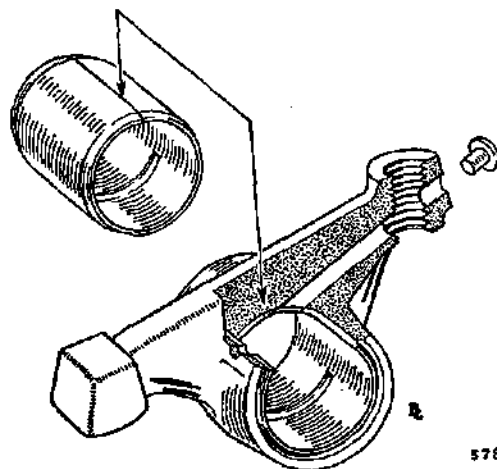

Fig. A.3

The forged-type valve rocker

- (5) Remove the shaft locating screw from the front bracket.
- (6) Withdraw the split pin and washers from the front end of the shaft.
- (7) Slide the rockers, brackets and springs from the shaft, noting their relative positions for correct refitting.
- (8) Unscrew the plug from the front end of the shaft and clean out the oilways.

Rockers and bushes

Check the rockers for wear. Two types of rocker are in use—pressed steel or forged; if the forged type is fitted the rockers can be rebushed, but worn pressed-steel rockers must be renewed.

To fit new bushes

- (9) Remove the old and press in new bushes with Service tool 18G 226 and 18G 226 A.
- (10) Locate the joint of the bush at the top as shown in Fig. A.3.
- (11) Remove the adjuster screw.
- (12) Drill out the plug in the end of the rocker with a No. 43 drill (2.26 mm.) and continue the oilway through the bush.
- (13) Replug the end hole with a rivet welded in position.
- (14) Continue the hole in the top of the rocker barrel with a No. 47 drill (1.98 mm.).
- (15) Burnish-ream the bush to the dimension given in 'GENERAL DATA'.

Reassembling

- (16) Reverse the dismantling procedure.
- (17) Fit the plugged end of the shaft and the tapped bracket at the front of the engine.
- (18) Tighten the cylinder head and rocker shaft nuts to the recommended torque and in the order shown in Fig. A.4.

Adjustment

- (19) Remove the sparking plugs, engage top gear and push the car forward to rotate the crankshaft. This operation can be also effected by jacking up one side of the front suspension until the road wheel can be rotated, and thus turn the crankshaft to the required position.
- (20) Rotate the crankshaft until the valve being checked has its tappet resting opposite the peak on the camshaft, i.e. valve completely closed. This cannot be observed accurately, therefore if checking is carried out according to the adjustment chart, this will avoid turning the crankshaft more than is necessary. The valve rocker clearance is given in 'GENERAL DATA'.
- (21) Hold the adjusting screw against rotation while slackening the locknut, insert the feeler gauge and turn the adjustment screw until the gauge is a sliding fit, tighten the locknut and recheck the clearance.
- (22) Refit the rocker cover with a new joint washer if necessary, and lower the car (if jacked up).

Adjust No. 1 rocker with No. 8 valve fully open

| | | | | | | | | | |
|---|---|---|---|---|---|---|---|---|---|
| " | " | 3 | " | " | " | 6 | " | " | " |
| " | " | 5 | " | " | " | 4 | " | " | " |
| " | " | 2 | " | " | " | 7 | " | " | " |
| " | " | 8 | " | " | " | 1 | " | " | " |
| " | " | 6 | " | " | " | 3 | " | " | " |
| " | " | 4 | " | " | " | 5 | " | " | " |
| " | " | 7 | " | " | " | 2 | " | " | " |

Section A.6

CYLINDER HEAD



Removing

- (1) Remove the bonnet.
 - (2) Drain the cooling system (Section C.1).
 - (3) Disconnect the battery and electrical connections from the cylinder head.
 - (4) Remove the carburetter air cleaner (Section A.1).
 - (5) Remove the carburetter (with cables attached) from the manifold and position it clear of the cylinder head.
 - (6) Disconnect the exhaust pipe from the manifold flange.
- Cooper 'S'. Remove the exhaust manifold as detailed in Section A.4.

- (7) Release the automatic advance suction pipe and remove the rocker cover.
- (8) Cooper 'S'. Remove the bolt (A) and nut (B) before releasing the remaining cylinder head nuts.
- (9) Progressively slacken and remove the cylinder head nuts in the reverse sequence shown in Fig. A.4.
- (10) Remove the rocker shaft, push-rods, and the radiator tie-plate from the thermostat housing.
- (11) Disconnect the top water hose and slacken the clip securing the water pump to cylinder head by-pass hose.
- (12) Disconnect the heater hose and cable from the water valve on the rear of the cylinder head.
- (13) Lift the cylinder head squarely off the studs; if the head does not release easily from the block, tap each side of the head with a soft-faced mallet. Lift the gasket from the studs.

Refitting

- (14) Reverse the removing procedure, noting the following points:
 - (a) Thoroughly clean the faces of the cylinder head and the top of the block; fit a new gasket without jointing compound or grease, it is marked 'TOP' and 'FRONT'.
 - (b) Progressively tighten the cylinder head and rocker shaft nuts, and finally tighten to the torque figures given in 'GENERAL DATA' and in the sequence shown on Fig. A.4.
- Cooper 'S'. The additional bolt and nut (Fig. A.4) must be tightened last.
- (15) Adjust the valve rocker clearances as detailed in 'Adjustment' (Section A.5). Start the engine, and when at normal running temperature re-check the clearances. ●

Section A.7

DECARBONIZING



- (1) Remove the cylinder head and gasket (Section A.6) and the valves (Section A.8).
- (2) Scrape the carbon from the piston crowns, cylinder head, valves, and cylinder block, leaving a ring of carbon around the periphery of each piston and the top of each bore. Blow all deposits of carbon from the head and block.
- (3) Refit the cylinder head (Section A.6).

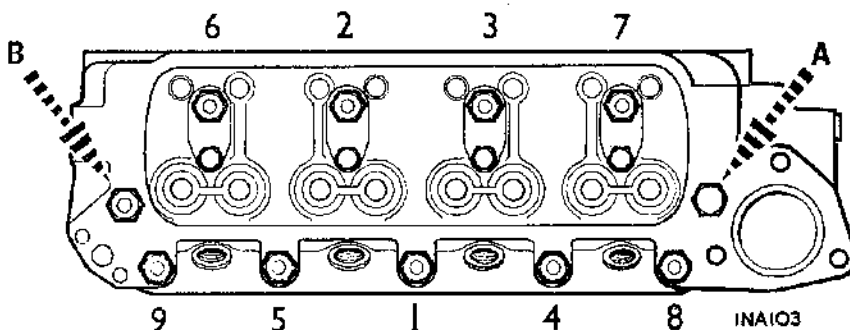

● Fig. A.4

The releasing and tightening sequence of the cylinder head retaining nuts. Arrows 'A' and 'B' indicate the additional bolt and nut on the Cooper 'S' head ●

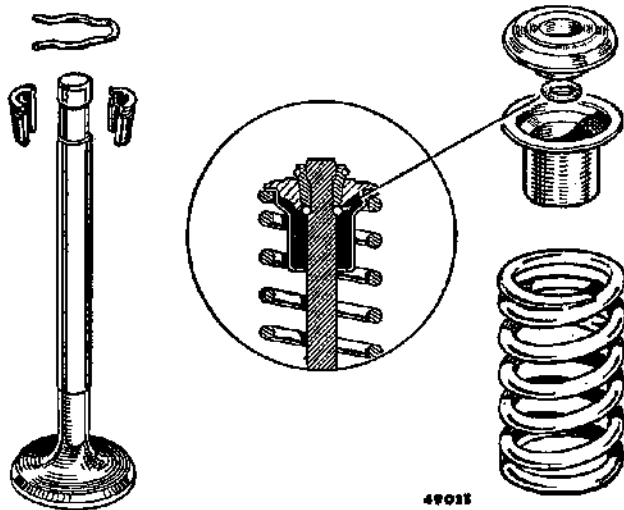

Fig. A.5

The component parts of the valve assembly

Section A.8

VALVES



Removing

- (1) Remove the cylinder head and gasket (Section A.6).
- (2) Withdraw the cotter clip (when fitted). ●
- (3) Compress the spring and extract the two halves of the cotter.
- (4) Slowly release the spring, remove the spring compressor and withdraw the retaining cap, shroud valve spring, and rubber seal.
- (5) Remove the valve. If the heads of the valves are not numbered, store them in such a way that they can be replaced in their original positions.

The Cooper 'S' has no cotter clips or shroud, and the rubber seal is fitted over the valve guide. Double valve springs are fitted.

Grinding

Clean the valves and seatings and examine them for pitting and unevenness. If the valves are in a very poor condition, fit new, otherwise reface them on a valve grinder.

Seats can be re-cut with special cutters available from BMC Service. Confine seat and valve grinding to the minimum and finally grind the valves onto the seatings with fine grinding paste.

Valve seat inserts

When it becomes necessary to fit inserts, machine the cylinder head to the dimensions given in Fig. A.7. The inserts should have an interference fit of .0025 to .0045 in. (.063 to .11 mm.) and must be pressed, not driven, into the cylinder head.

Valve guides

Remove by driving downwards into the combustion chambers. Drive new guides into position until they

A.6

protrude $\frac{1}{16}$ in. (15.08 mm.) above the machined spring seats (Fig. A.6). Fit the inlet guides with the largest chamfer at the top, and the exhaust with the counterbore at the bottom.

Refitting

Reverse instructions (1) to (5) above.

Section A.9

TAPPETS



Removing

- (1) Remove the air cleaner(s) and carburetter(s) (Sections A.1 and A.2).
- (2) Remove the rocker cover and shaft assembly (Section A.5).
- (3) Remove the manifold (Section A.4) and the push-rods.
- (4) Remove the tappet covers and tappets.
- (5) Fit new tappets by selective assembly so that they just fall into their guides under their own weight, when lubricated.

Refitting

Reverse the dismantling operations, taking care to replace the tappets in their original positions.

Section A.10

DISTRIBUTOR SPINDLE



Removing

- (1) Remove the distributor (Section B.1).
- (2) Take out the screw securing the distributor housing to the cylinder block and carefully withdraw the housing to avoid damage to the 'O' ring seal (later models only). The upper end of the spindle is drilled and tapped with a $\frac{1}{8}$ -in. UNF. thread; screw in a suitable bolt and withdraw the spindle.

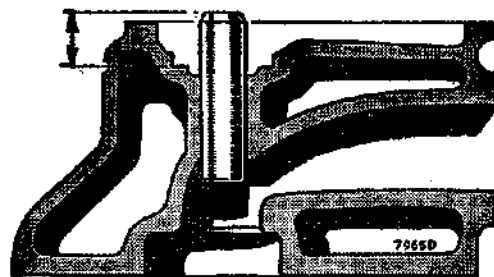

Fig. A.6

The fitting position for the valve guide

Adjustment

- (19) Remove the sparking plugs, engage top gear and push the car forward to rotate the crankshaft. This operation can be also effected by jacking up one side of the front suspension until the road wheel can be rotated, and thus turn the crankshaft to the required position.
- (20) Rotate the crankshaft until the valve being checked has its tappet resting opposite the peak on the camshaft, i.e. valve completely closed. This cannot be observed accurately, therefore if checking is carried out according to the adjustment chart, this will avoid turning the crankshaft more than is necessary. The valve rocker clearance is given in 'GENERAL DATA'.
- (21) Hold the adjusting screw against rotation while slackening the locknut, insert the feeler gauge and turn the adjustment screw until the gauge is a sliding fit, tighten the locknut and recheck the clearance.
- (22) Refit the rocker cover with a new joint washer if necessary, and lower the car (if jacked up).

Adjust No. 1 rocker with No. 8 valve fully open

| | | | | | | | | |
|---|---|---|---|---|---|---|---|---|
| " | " | 3 | " | " | 6 | " | " | " |
| " | " | 5 | " | " | 4 | " | " | " |
| " | " | 2 | " | " | 7 | " | " | " |
| " | " | 8 | " | " | 1 | " | " | " |
| " | " | 6 | " | " | 3 | " | " | " |
| " | " | 4 | " | " | 5 | " | " | " |
| " | " | 7 | " | " | 2 | " | " | " |

- (5) Remove the rocker cover, rocker shaft, push-rods, sparking plugs, and the three screws securing the radiator tie-plate to the thermostat housing.
- (6) Disconnect the radiator to cylinder head hose, the suction advance pipe from the clip on the water inlet pipe and the heater hose from the water valve at the rear of the cylinder head.
- (7) Slacken the water by-pass hose.
- (8) Remove the remaining cylinder head nuts.
NOTE.—The Cooper 'S' has an additional bolt at the front of the cylinder head.
- (9) Lift the head squarely. If the joint sticks, tap each side of the head with a wooden or hide mallet. Lift the gasket from the studs.

Refitting

Reverse the removing procedure, noting the following points.

- (10) Thoroughly clean the faces of the cylinder head and the top of the block, and fit a new gasket without jointing compound or grease. The gasket is marked 'TOP' and 'FRONT'.
- (11) Tighten the cylinder head and rocker shaft nuts to the correct torque and in the order shown in Fig. A.4. The additional bolt on the Cooper 'S' must be tightened last. **Do not overtighten.**
- (12) Adjust the valve rocker clearances, start the engine and when warm re-check.

Section A.6

CYLINDER HEAD



Removing

- (1) Remove the bonnet.
- (2) Drain the cooling system (Section C.1).
- (3) Disconnect the battery.
- (4) Remove the air cleaner (Section A.1), carburetter (Section A.2), and exhaust manifold (Section A.4).

Section A.7

DECARBONIZING



- (1) Remove the cylinder head and gasket (Section A.6) and the valves (Section A.8).
- (2) Scrape the carbon from the piston crowns, cylinder head, valves, and cylinder block, leaving a ring of carbon around the periphery of each piston and the top of each bore. Blow all deposits of carbon from the head and block.
- (3) Refit the cylinder head (Section A.6).

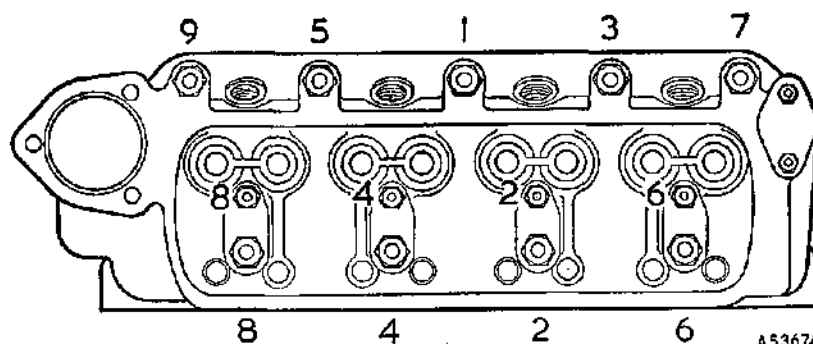

Fig. A.4

The order of slackening and tightening the cylinder head retaining nuts

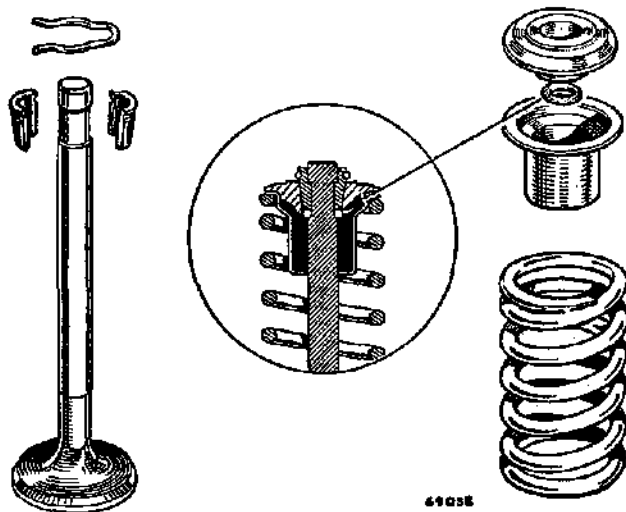

Fig. A.5

The component parts of the valve assembly

Section A.8

VALVES



Removing

- (1) Remove the cylinder head and gasket (Section A.6).
- (2) Withdraw the cotter clip.
- (3) Compress the spring and extract the two halves of the cotter.
- (4) Slowly release the spring, remove the spring compressor and withdraw the retaining cap, shroud valve spring, and rubber seal.
- (5) Remove the valve. If the heads of the valves are not numbered, store them in such a way that they can be replaced in their original positions.

The Cooper 'S' has no cotter clips or shroud, and the rubber seal is fitted over the valve guide. Double valve springs are fitted.

Grinding

Clean the valves and seatings and examine them for pitting and unevenness. If the valves are in a very poor condition, fit new, otherwise reface them on a valve grinder.

Seats can be re-cut with special cutters available from BMC Service. Confine seat and valve grinding to the minimum and finally grind the valves onto the seatings with fine grinding paste.

Valve seat inserts

When it becomes necessary to fit inserts, machine the cylinder head to the dimensions given in Fig. A.7. The inserts should have an interference fit of .0025 to .0045 in. (.063 to .11 mm.) and must be pressed, not driven, into the cylinder head.

Valve guides

Remove by driving downwards into the combustion chambers. Drive new guides into position until they

protrude $\frac{1}{16}$ in. (15.08 mm.) above the machined spring seats (Fig. A.6). Fit the inlet guides with the largest chamfer at the top, and the exhaust with the counterbore at the bottom.

Refitting

Reverse instructions (1) to (5) above.

Section A.9

TAPPETS



Removing

- (1) Remove the air cleaner(s) and carburetter(s) (Sections A.1 and A.2).
- (2) Remove the rocker cover and shaft assembly (Section A.5).
- (3) Remove the manifold (Section A.4) and the push-rods.
- (4) Remove the tappet covers and tappets.
- (5) Fit new tappets by selective assembly so that they just fall into their guides under their own weight, when lubricated.

Refitting

Reverse the dismantling operations, taking care to replace the tappets in their original positions.

Section A.10

DISTRIBUTOR SPINDLE



Removing

- (1) Remove the distributor (Section B.1).
- (2) Take out the screw securing the distributor housing to the cylinder block and carefully withdraw the housing to avoid damage to the 'O' ring seal (later models only). The upper end of the spindle is drilled and tapped with a $\frac{1}{8}$ -in. UNF. thread; screw in a suitable bolt and withdraw the spindle.

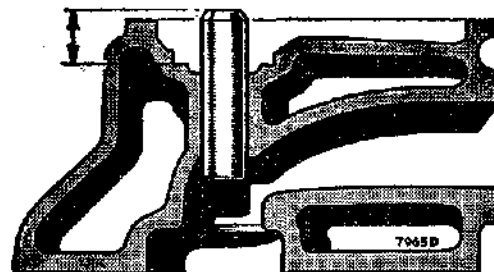

Fig. A.6

The fitting position for the valve guide

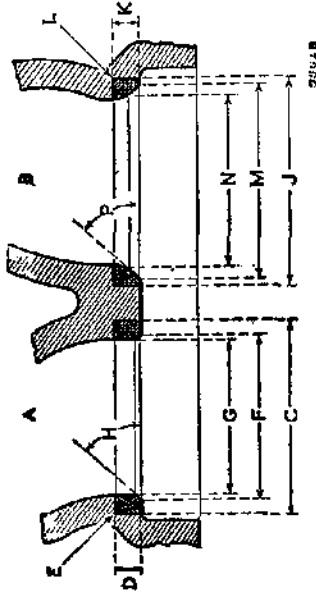

Fig. A.7
Valve seat machining dimensions

| | EXHAUST 'A' | | | | | | | | | | INLET 'B' | | | | | | | | | | | | | |
|----------------------|--|-------------------------------------|-----------------------------------|---|---|-----|---|-------------------------------------|-----------------------------------|---|---|-----|--|-------------------------------------|--------------------|---|---|-----|---|-------------------------------------|--------------------|---|---|-----|
| | C | D | E | F | G | H | J | K | L | M | N | P | C | D | E | F | G | H | J | K | L | M | N | P |
| MINI | 1.124 to 1.125 in. (28.55 to 28.58 mm.) | .186 to .188 in. (4.72 to 4.77 mm.) | Maximum radius .015 in. (.38 mm.) | 1.0235 to 1.0435 in. (25.99 to 26.50 mm.) | .844 in. (21.43 mm.) | 45° | 1.187 to 1.188 in. (30.16 to 30.17 mm.) | .186 to .188 in. (4.72 to 4.77 mm.) | Maximum radius .015 in. (.38 mm.) | 1.0855 to 1.1055 in. (27.58 to 28.07 mm.) | 1.000 to 1.006 in. (25.4 to 25.55 mm.) | 45° | 1.124 to 1.125 in. (28.55 to 28.58 mm.) | .186 to .188 in. (4.72 to 4.77 mm.) | .015 in. (.38 mm.) | 1.0235 to 1.0435 in. (25.99 to 26.50 mm.) | .844 in. (21.43 mm.) | 45° | 1.3075 to 1.3085 in. (33.21 to 33.23 mm.) | .186 to .188 in. (4.72 to 4.77 mm.) | .015 in. (.38 mm.) | 1.116 to 1.136 in. (28.34 to 29.2 mm.) | 1.066 to 1.072 in. (27.07 to 27.22 mm.) | 45° |
| 997-c.c. COOPER | 1.124 to 1.125 in. (28.55 to 28.58 mm.) | .186 to .188 in. (4.72 to 4.77 mm.) | .015 in. (.38 mm.) | 1.0235 to 1.0435 in. (25.99 to 26.50 mm.) | .906 to .912 in. (23.01 to 23.16 mm.) | 45° | 1.3745 to 1.3755 in. (34.90 to 34.95 mm.) | .186 to .188 in. (4.72 to 4.77 mm.) | .015 in. (.38 mm.) | 1.206 to 1.226 in. (30.60 to 31.15 mm.) | 1.066 to 1.072 in. (27.07 to 27.22 mm.) | 45° | 1.124 to 1.125 in. (28.55 to 28.58 mm.) | .186 to .188 in. (4.72 to 4.77 mm.) | .015 in. (.38 mm.) | 1.0235 to 1.0435 in. (25.99 to 26.50 mm.) | .906 to .912 in. (23.01 to 23.16 mm.) | 45° | 1.3745 to 1.3755 in. (34.90 to 34.95 mm.) | .186 to .188 in. (4.72 to 4.77 mm.) | .015 in. (.38 mm.) | 1.206 to 1.226 in. (30.60 to 31.15 mm.) | 1.066 to 1.072 in. (27.07 to 27.22 mm.) | 45° |
| 998-c.c. COOPER | 1.124 to 1.125 in. (28.55 to 28.58 mm.) | .186 to .188 in. (4.72 to 4.77 mm.) | .015 in. (.38 mm.) | 1.0235 to 1.0435 in. (25.99 to 26.50 mm.) | .906 to .912 in. (23.01 to 23.16 mm.) | 45° | 1.3745 to 1.3755 in. (34.90 to 34.95 mm.) | .186 to .188 in. (4.72 to 4.77 mm.) | .015 in. (.38 mm.) | 1.206 to 1.226 in. (30.60 to 31.15 mm.) | 1.066 to 1.072 in. (27.07 to 27.22 mm.) | 45° | 1.124 to 1.125 in. (28.55 to 28.58 mm.) | .186 to .188 in. (4.72 to 4.77 mm.) | .015 in. (.38 mm.) | 1.0235 to 1.0435 in. (25.99 to 26.50 mm.) | .906 to .912 in. (23.01 to 23.16 mm.) | 45° | 1.3745 to 1.3755 in. (34.90 to 34.95 mm.) | .186 to .188 in. (4.72 to 4.77 mm.) | .015 in. (.38 mm.) | 1.206 to 1.226 in. (30.60 to 31.15 mm.) | 1.066 to 1.072 in. (27.07 to 27.22 mm.) | 45° |
| 970-c.c. COOPER 'S' | 1.2465 to 1.2475 in. (31.66 to 31.7 mm.) | .186 to .188 in. (4.72 to 4.77 mm.) | .015 in. (.38 mm.) | 1.2065 to 1.2265 in. (30.65 to 31.16 mm.) | 1.121 to 1.141 in. (28.47 to 28.98 mm.) | 45° | 1.4365 to 1.4375 in. (36.5 to 36.52 mm.) | .186 to .188 in. (4.72 to 4.77 mm.) | .015 in. (.38 mm.) | 1.206 to 1.226 in. (30.60 to 31.15 mm.) | 1.066 to 1.072 in. (27.07 to 27.22 mm.) | 45° | 1.2465 to 1.2475 in. (31.66 to 31.7 mm.) | .186 to .188 in. (4.72 to 4.77 mm.) | .015 in. (.38 mm.) | 1.2065 to 1.2265 in. (30.65 to 31.16 mm.) | 1.121 to 1.141 in. (28.47 to 28.98 mm.) | 45° | 1.4365 to 1.4375 in. (36.5 to 36.52 mm.) | .186 to .188 in. (4.72 to 4.77 mm.) | .015 in. (.38 mm.) | 1.206 to 1.226 in. (30.60 to 31.15 mm.) | 1.066 to 1.072 in. (27.07 to 27.22 mm.) | 45° |
| 1071-c.c. COOPER 'S' | 1.2465 to 1.2475 in. (31.66 to 31.7 mm.) | .186 to .188 in. (4.72 to 4.77 mm.) | .015 in. (.38 mm.) | 1.2065 to 1.2265 in. (30.65 to 31.16 mm.) | 1.121 to 1.141 in. (28.47 to 28.98 mm.) | 45° | 1.4365 to 1.4375 in. (36.5 to 36.52 mm.) | .186 to .188 in. (4.72 to 4.77 mm.) | .015 in. (.38 mm.) | 1.206 to 1.226 in. (30.60 to 31.15 mm.) | 1.066 to 1.072 in. (27.07 to 27.22 mm.) | 45° | 1.2465 to 1.2475 in. (31.66 to 31.7 mm.) | .186 to .188 in. (4.72 to 4.77 mm.) | .015 in. (.38 mm.) | 1.2065 to 1.2265 in. (30.65 to 31.16 mm.) | 1.121 to 1.141 in. (28.47 to 28.98 mm.) | 45° | 1.4365 to 1.4375 in. (36.5 to 36.52 mm.) | .186 to .188 in. (4.72 to 4.77 mm.) | .015 in. (.38 mm.) | 1.206 to 1.226 in. (30.60 to 31.15 mm.) | 1.066 to 1.072 in. (27.07 to 27.22 mm.) | 45° |
| 1275-c.c. COOPER 'S' | 1.2465 to 1.2475 in. (31.66 to 31.7 mm.) | .186 to .188 in. (4.72 to 4.77 mm.) | .015 in. (.38 mm.) | 1.2065 to 1.2265 in. (30.65 to 31.16 mm.) | 1.121 to 1.141 in. (28.47 to 28.98 mm.) | 45° | 1.4365 to 1.4375 in. (36.5 to 36.52 mm.) | .186 to .188 in. (4.72 to 4.77 mm.) | .015 in. (.38 mm.) | 1.206 to 1.226 in. (30.60 to 31.15 mm.) | 1.066 to 1.072 in. (27.07 to 27.22 mm.) | 45° | 1.2465 to 1.2475 in. (31.66 to 31.7 mm.) | .186 to .188 in. (4.72 to 4.77 mm.) | .015 in. (.38 mm.) | 1.2065 to 1.2265 in. (30.65 to 31.16 mm.) | 1.121 to 1.141 in. (28.47 to 28.98 mm.) | 45° | 1.4365 to 1.4375 in. (36.5 to 36.52 mm.) | .186 to .188 in. (4.72 to 4.77 mm.) | .015 in. (.38 mm.) | 1.206 to 1.226 in. (30.60 to 31.15 mm.) | 1.066 to 1.072 in. (27.07 to 27.22 mm.) | 45° |

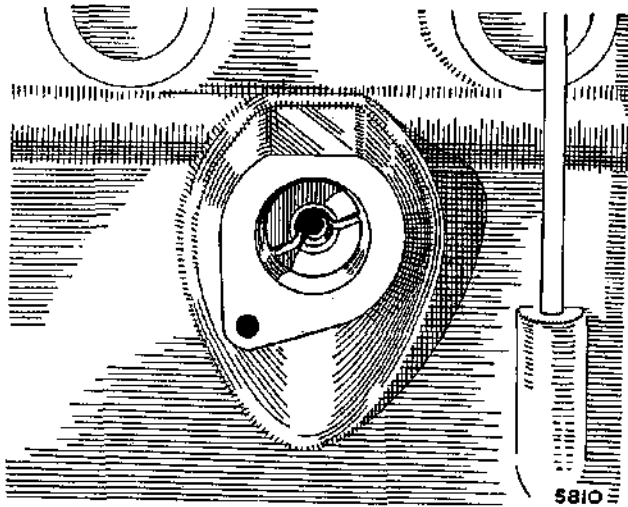

Fig. A.8

The distributor drive with the slot in the correct position and the large offset uppermost

Refitting

- (3) Turn the crankshaft until No. 1 piston is at T.D.C. on the compression stroke (No. 4 cylinder exhaust and inlet valves rocking and the 1/4 mark on the flywheel against the pointer).
- (4) Hold the spindle so that the drive slot is in the position shown (Fig. A.8) with the large offset uppermost, and enter the gear. As the gear engages the camshaft the spindle will turn anti-clockwise.
- (5) Refit the distributor (Sections B.1 and B.2).

Section A.11

FLYWHEEL AND CLUTCH

Removing

- (1) Disconnect the coil (or solenoid) leads and remove the coil (or solenoid).
- (2) Remove the starter (Section N.3).
- (3) Unhook the clutch lever spring, withdraw the lever pivot pin, pull the push-rod from the slave cylinder and remove the lever from the clutch housing.
- (4) Take off the slave cylinder.
- (5) Disconnect the exhaust pipe/manifold clamp.
- (6) Detach the radiator support bracket from the thermostat housing.
- (7) Unscrew the two nuts and set screws securing the right-hand engine mounting to the sub-frame side-member.
- (8) Take out the clutch cover screws.
- (9) Raise the engine just enough to allow the removal of the clutch cover. Do not let the fan blades damage the radiator.
- (10) Remove the three nuts and the clutch thrust plate

A.8

from the pressure spring housing. When a diaphragm clutch is fitted, release the spring retainer to detach the thrust plate.

- (11) Bring Nos. 1 and 4 pistons to T.D.C. to prevent the primary gear 'C' washer from falling and being wedged behind the flywheel. With the crankshaft in any other position this could happen and result in damage as the flywheel is withdrawn.
- (12) Tap up the locking washer and slacken the flywheel retaining screw three or four threads. Use Service tools 18G 304 and 18G 304 M to free the flywheel from the taper on the crankshaft. Remove the tool as soon as the flywheel is free.
- (13) Unscrew the flywheel retaining screws and take off the driving washer.
- (14) Withdraw the flywheel and clutch together.
- (15) Dismantle the clutch as described in Section E.1.

NOTES:

- (A) As the flywheel is pulled from the shaft, oil from the annulus behind the flywheel oil seal may spill down the face of the flywheel onto the clutch driven plate. Look out for this when dismantling to avoid assuming that the oil has passed the seal during normal running.
- (B) In early engines a rubber plug was fitted into the rear end of the crankshaft as an added precaution against oil leaking past the normal brass taper plug. An improved brass plug is now fitted and the rubber is discontinued.
- (C) Later engines have non-lubricated bushes in the crankshaft primary gear and the flywheel oil seal is not fitted.

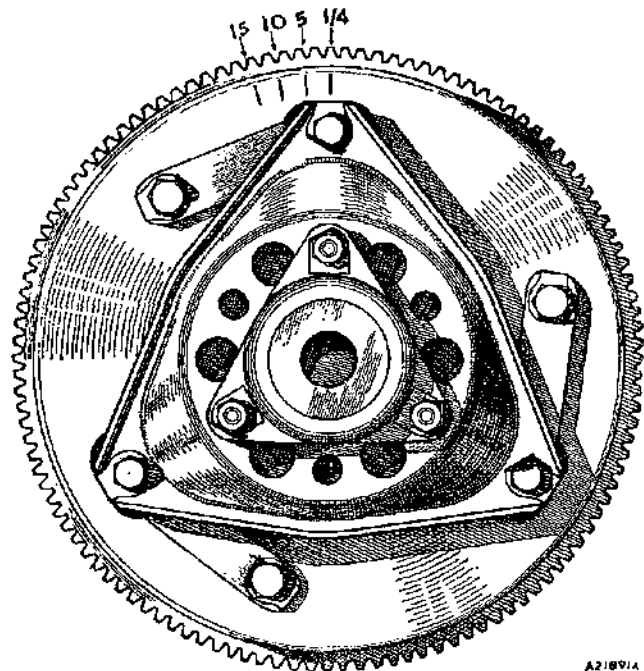

Fig. A.9

The flywheel and clutch assembly

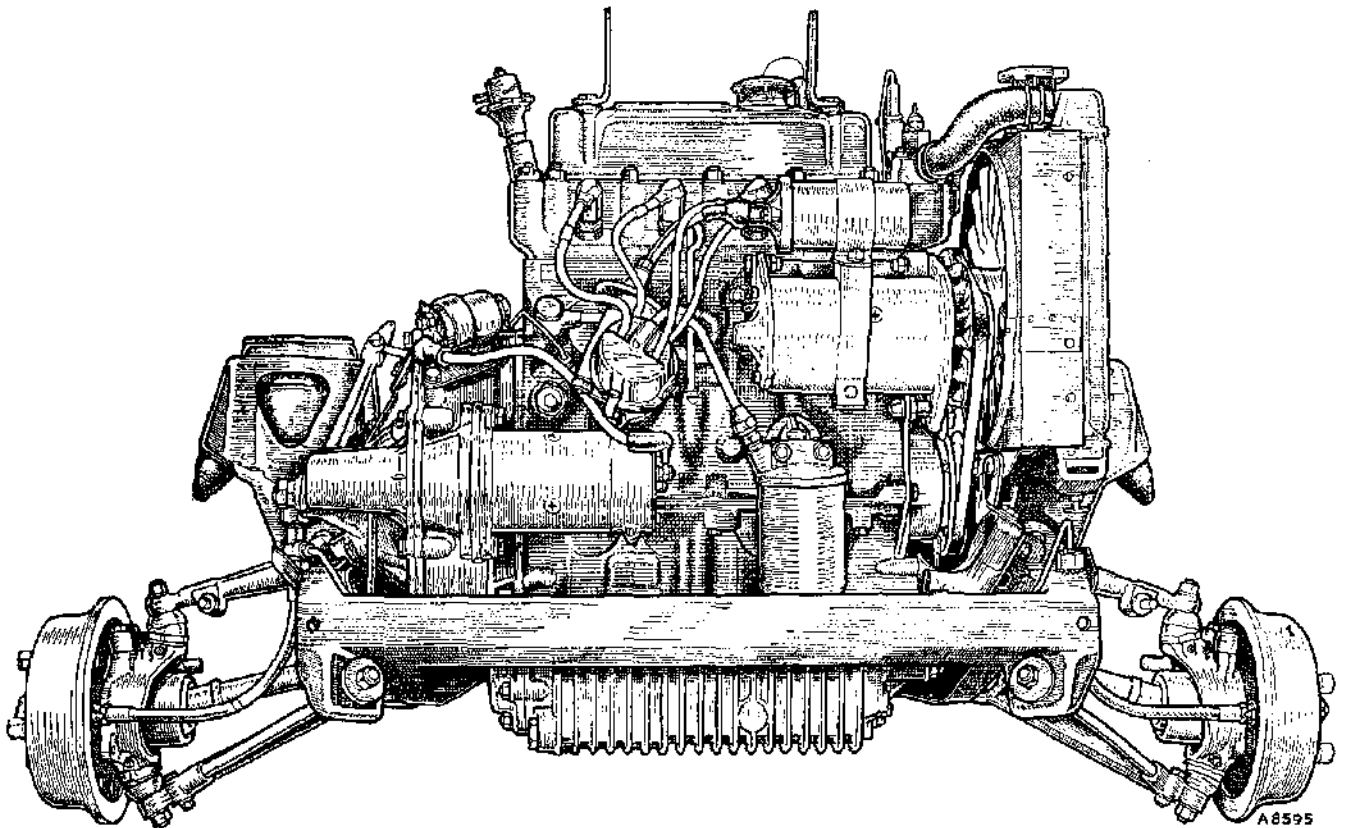

Fig. A.10

The engine and front suspension assembly

Starter ring

If a new starter ring is needed, split the old one with a cold chisel. Clean the bore of the new ring and the mating surface of the flywheel, heat the ring to a temperature of 300 to 400° C. (575 to 752° F.), indicated by a light blue colour, and fit it to the flywheel with the lead of the teeth towards the flywheel register. Allow it to cool naturally.

Refitting

- (16) Assemble the clutch.
- (17) Lubricate the flywheel oil seal (if fitted).
- (18) Ensure that the 'C' washer is correctly positioned and then turn the crankshaft to bring Nos. 1 and 4 pistons to T.D.C.
- (19) The crankshaft primary gear splines should be lightly wiped with Duckham's M-B grease.
- (20) Clean and dry the crankshaft and flywheel tapers; they must be assembled dry.
- (21) Fit the flywheel and clutch assembly to the shaft, replace the washer and retaining screws.
- (22) Tighten the screw to the recommended torque (see 'GENERAL DATA') and tap over the locking washer.
- (23) Refit the clutch thrust plate.
- (24) Lower the engine and carry out the removal operations 1 to 8 in reverse order.

Section A.12

ENGINE AND SUB-FRAME ASSEMBLY

Removing

- (1) Remove the bonnet, drain the cooling system and remove the front grille.
- (2) Disconnect the battery.
- (3) Disconnect the electrical connections from the engine.
- (4) Disconnect the speedometer cable from the instrument.
- (5) Disconnect the heater hoses.
- (6) Disconnect the brake pipes at the three-way union.
- (7) Use Service tool 18G 1063 and disconnect the steering-rack ball joints.
- (8) Disconnect the tie-rod from the cylinder block and swing the rod away from the engine.
- (9) *Cooper 'S'*. Detach the servo vacuum pipe from the inlet manifold.
- (10) Remove the front hydraulic dampers (fitted to non-Hydrolastic suspension vehicles only).
- (11) Remove the exhaust pipe (Section A.3).
- (12) Remove the air cleaner and carburetter (Sections A.1 and A.2).
- (13) *Cooper and Mk. II models*. Remove the remote control gear-change extension (Section A.32).
- (14) Remove the hexagon plug with the anti-rattle spring and plunger from the gear change extension.

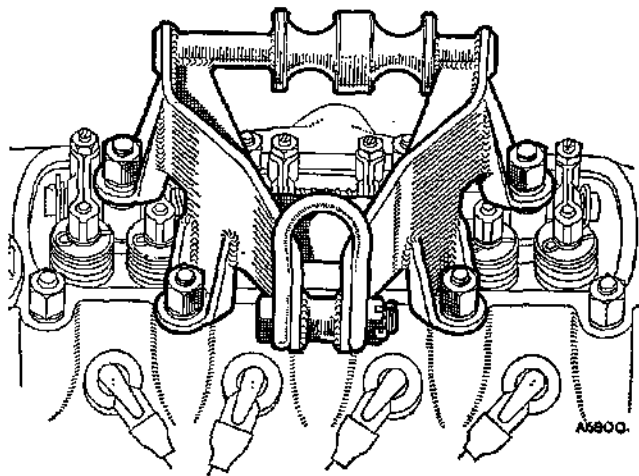

Fig. A.11

Use the individual front lifting eye of the attachment to give an angled lift when removing and refitting the power unit

- (15) Remove the gear lever retaining plate; pull the lever out of the casing into the car.
- (16) Remove the slave cylinder securing bolts and attach the unit to the bulkhead (do not disconnect the hose).
- (17) Depressurize and evacuate the models fitted with Hydrolastic suspension (Section H.7) and disconnect both hoses.
- (18) Support the body with slings under the front wings, and the engine below the transmission casing.
- (19) Knock back the locking tabs and withdraw the four body to sub-frame bolts (nuts if studs are fitted), two on each side of the bulkhead cross-member. Take out the four set screws securing the rear of the sub-frame to the front floor and the two screws securing the front of the frame to the bottom of the grille panel.
- (20) Lift the body clear of the engine and withdraw the sub-frame and engine assembly.

Removing engine from sub-frame

- (21) Remove the rocker cover nuts and fit the engine lifting bracket (Fig. A.11).
- (22) Drain the oil. Disconnect the drive shafts at the differential (Section G).
- (23) Support the sub-frame under both side-members and take the weight of the engine on the lifting equipment. Take out the two screws securing each engine mounting to the sub-frame.
- (24) Lift the engine out of the frame.

A.10

Refitting

- (25) Reverse the removal instructions.

NOTE.—On vehicles NOT fitted with the remote control gear-change pull the gear lever up into the interior of the car before the body is lowered onto the frame. Bleed the brakes and clutch.

Section A.13

ENGINE AND TRANSMISSION

Removing

- (1) The engine and transmission assembly can be taken out through the bonnet aperture as follows:
- (2) Refer to Section A.12 and carry out instruction Nos. (1) to (5), (8) and (12) to (16).
- (3) Remove the windscreen washer bottle and bracket (if necessary).
- (4) Disconnect the drive shafts at the differential.
- (5) Disconnect the exhaust pipe from the manifold and secure the pipe against the bulkhead.
- (6) Remove the rocker cover nuts and fit the engine lifting bracket (Fig. A.11).
- (7) Take the weight of the engine on the lifting equipment and unscrew the two set screws securing each engine mounting to the sub-frame and lift out the engine.

Refitting

- (8) Reverse the removal instructions.

NOTES.—On vehicles NOT fitted with the remote control gear-change pull the gear lever up into the interior of the car before the engine is lowered into position. Keep the sliding joints pushed well onto the drive shaft splines while the flexible couplings are moved into position.

COOPER

Removing

- (1) Carry out the instructions (1) to (9) and (16) in Section A.12.
- (2) Remove the fresh-air motor (when fitted).
- (3) Disconnect the oil gauge pipe.
- (4) Take off the distributor cap.
- (5) Remove the carburetters and air cleaners (Sections A.1 and A.2).
- (6) Remove the exhaust pipe assembly (Section A.3).
- (7) Remove the three bolts securing the rear extension mounting to the floor (Fig. A.12).

- (8) Unscrew the gear lever knob and take out the screws with the rubber cover and plate.
- (9) Remove the gear-change extension. Disconnect the hydraulic and vacuum pipe and remove the brake servo (Cooper 'S').

Refitting

Reverse the removing instructions.

Section A.14

ENGINE MOUNTINGS

Removing

Left-hand

- (1) Remove the radiator (Section C.3).
- (2) Support the engine with the attachment shown in Fig. A.11; use the central 'straight lift' position and take the weight off the mounting.
- (3) Remove the nuts securing the mounting bracket to the transmission casing and the two set screws securing the mounting to the sub-frame side-members; withdraw the bracket and mounting assembly.

Right-hand

- (4) Remove the clutch cover and engine mounting together as detailed in Section A.11.

Refitting

Reverse the removing instructions.

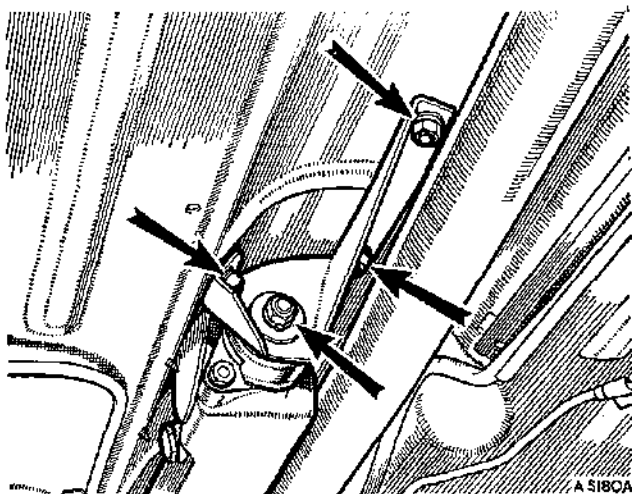

Fig. A.12

The securing points for the remote control gear-change extension

Section A.15

TIMING COVER

Removing

If the fan cowling is not the later split-type the engine will have to be removed as in Section A.13; otherwise proceed as follows.

- (1) Remove the radiator (Section C.3).
- (2) Slacken the dynamo or alternator bolts and remove the fan belt.
- (3) Withdraw the crankshaft pulley.
- (4) Remove the cover securing screws and lift off the cover.

Refitting

- (5) Reverse the removing instructions when refitting the cover. The oil seal in the cover must be renewed if it shows signs of deterioration, using Service tool 18G 134 together with adaptor 18G 134 BD.

- (6) The oil thrower behind the crankshaft pulley must be fitted with the face marked 'F' away from the engine. Fill the annular groove of the seal with grease and use Service tool 18G 1044 to centralize the cover to the crankshaft.

NOTE.—The early type front cover and oil thrower must only be used together. The oil thrower must be fitted with its concave side facing away from the engine.

- (7) Use Service tool 18G 138 to centralize the seal to the crankshaft or use the crankshaft pulley.
- (8) Fill the groove of the seal with grease, lubricate the pulley hub and rotate the hub through the cover oil seal.
- (9) To ensure correct centralization the cover and hub should now be fitted together, aligning the keyway in the pulley with the key in the crankshaft.
- (10) Insert the cover retaining screws and tighten them evenly.
- (11) Refit and tighten the crankshaft pulley bolt to the torque figure given in 'GENERAL DATA' and tap over the locking washer.

Section A.16

TIMING GEARS AND CHAIN

Removing

- (1) Remove the timing cover (Section A.15).
- (2) Withdraw the oil thrower.
- (3) Unlock the camshaft chain wheel nut, unscrew and remove the nut and lock washer.

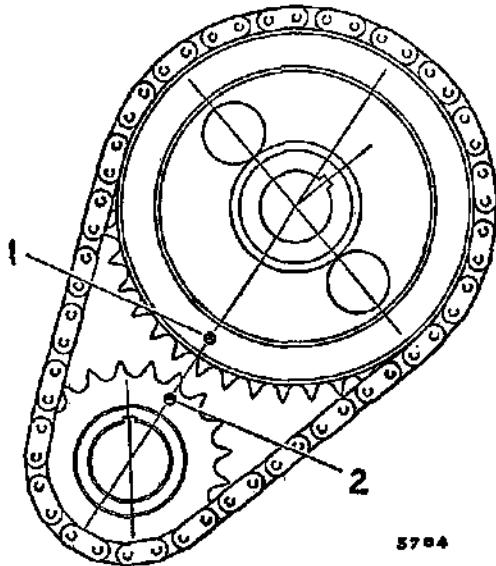

Fig. A.13

The timing gears assembled into the timing chain with the two marks on the gears opposite each other

- (4) Pull both chain wheels, with the chain at the same time. Note the thickness of the packing shims behind the crankshaft wheel.
- (5) Extract the wheels from the chain.

Refitting

- (6) Place the crankshaft gear packing shims in position and turn the shaft to bring the key to the top.
- (7) Bring the camshaft keyway to the position shown in Fig. A.13 (approx. 1 o'clock).
- (8) Assemble the two wheels in the chain with the marks opposite each other as in Fig. A.13. Push the wheels onto the shafts, turning the camshaft slightly as required to line up the key. Push the wheels as far as they will go and secure the camshaft gear with the lock washer and nut.
- (9) Check the alignment of the wheels by placing a straight-edge across the teeth of the camshaft and crankshaft gears and measuring the gap between the straight-edge and the crankshaft gear. Adjust with shims behind the crankshaft gear as required.
- (10) Refer to Section A.15 'Refitting', items (5) to (11).

Section A.17

VALVE TIMING

Checking

- (1) Adjust the rocker clearance of No. 1 inlet valve to .019 in. (.48 mm.), .021 in. (.53 mm.) Cooper 'S', and turn the crankshaft until the valve is about to open.

A.12

- (2) Take off the flywheel inspection hole cover. The pointer should now be opposite the 5° mark on the flywheel.
- (3) After checking, reset the rocker clearance of No. 1 inlet valve to .011 in. (.28 mm.)—engine hot.

Section A.18

FLYWHEEL HOUSING AND PRIMARY GEAR

Removing

- (1) Remove the engine (Section A.13).
- (2) Remove the flywheel and clutch assembly (Section A.11).
- (3) Remove the screws and nuts securing the housing; note their positions for correct replacement.
- (4) When withdrawing the housing and to avoid damage to the oil seal use Service tool 18G 570, or 18G 1043 if a red silicon rubber oil seal is fitted (Fig. A.15).
- (5) Extract the circlip and remove the primary gear.

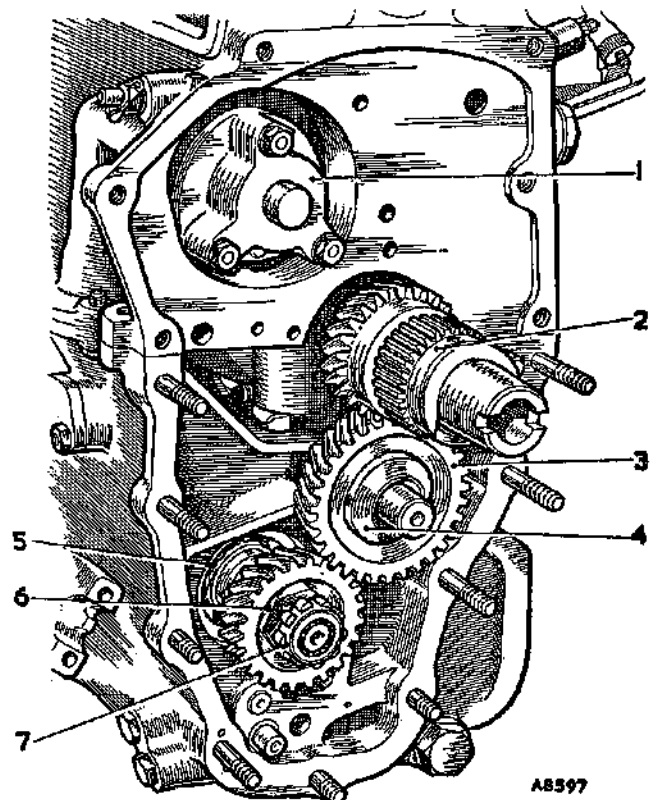

Fig. A.14

The engine and transmission assembly with the flywheel housing removed, showing the gear train to the first motion shaft

- | | |
|------------------------------|-------------------------------------|
| 1. Oil pump. | 5. First motion shaft bearing. |
| 2. Crankshaft primary gear. | 6. First motion shaft driving gear. |
| 3. Idler gear. | 7. Roller bearing. |
| 4. Idler gear thrust washer. | |

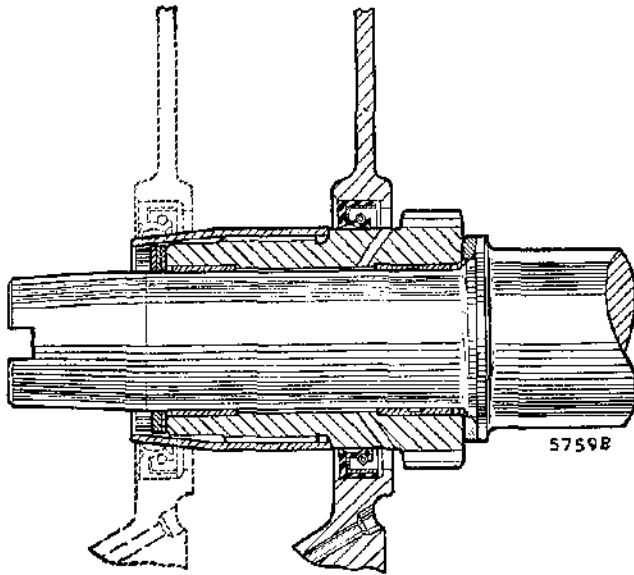

Fig. A.15

The Service tool 18G 1043 positioned over the clutch splines of the crankshaft primary gear to prevent damage to the lip of the oil seal

Refitting

- (6) Check the primary gear running clearance (Fig. A.16). Fit the inner thrust washer with its chamfered bore against the crankshaft flange.
- (7) Renew the crankshaft primary gear oil seal if it shows signs of damage or oil leakage, using Service tool 18G 134 and adaptor 18G 134 BC.
This seal can also be renewed without removing the housing or draining the engine/transmission unit (see Section A.30).
- (8) Refit the housing, using 18G 1043 to protect the red silicon rubber oil seal. Service tool 18G 570 must only be used for assembly with the old-type oil seal. Lubricate the oil seal before assembly. Fit a new joint washer.
- (9) Tighten the nuts and set screws to the recommended torque see 'GENERAL DATA'. It is important to return the set screws to the positions from which they were removed.

Later engines were fitted with non-lubricated bushes in the primary gear. No oil feed is provided from the crankshaft and no oil seal is fitted in the flywheel.

- (10) Remove the primary gear as described in Section A.18.
- (11) When refitting, check the running clearance (Fig. A.17).
- (12) Adjust by fitting the appropriate thrust washer with the chamfered inner edge of the washer to face the crankshaft (see Fig. A.17).

Primary gear bushes

If new bushes are fitted, line-ream them to the dimensions given in Fig. A.18.

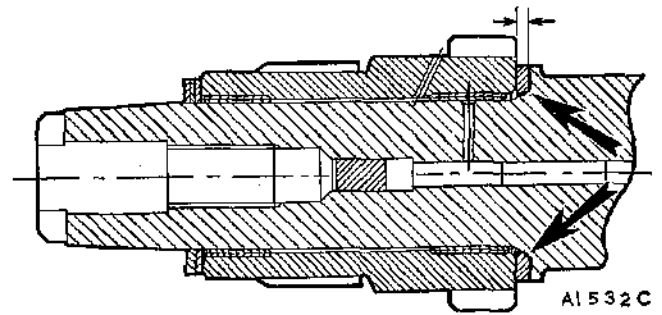

Fig. A.16

The crankshaft primary gear with lubricated bushes must be assembled with the correct running clearance of between .003 and .006 in. (.076 and .152 mm.). Measure the gap indicated and use the following table to determine the correct thickness of the thrust washer required to obtain this clearance

| When gap is | Use washer thickness |
|--|--|
| .1295 to .1315 in. (3.27 to 3.34 mm.) | .125 to .127 in. (3.17 to 3.22 mm.) |
| .1315 to .1335 in. (3.34 to 3.39 mm.) | .127 to .129 in. (3.22 to 3.27 mm.) |
| .1335 in. to .1345 in. (3.39 to 3.42 mm.) | .129 to .131 in. (3.27 to 3.32 mm.) |

First motion shaft outer race

Removing

- (1) Extract the spring ring from above the outer race
- (2) Expand the housing by immersion in very hot water. Do not use other methods of heating the housing.

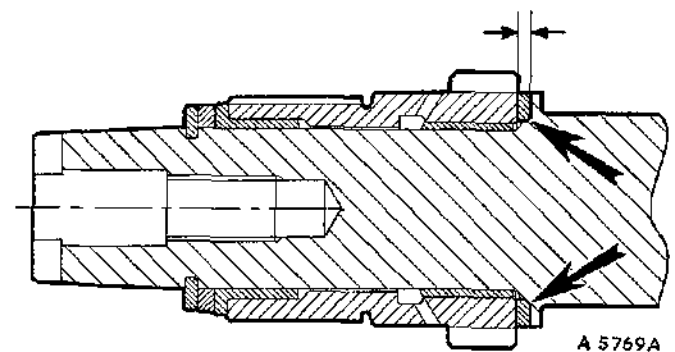

Fig. A.17

The correct running clearance is .0035 to .0065 in. (.0885 to .1645 mm.). Measure the gap indicated and fit the appropriate thrust washer as given below to obtain this clearance

| When gap is | Use washer thickness |
|---|--|
| .1175 to .119 in. (2.875 to 3.025 mm.) | .112 to .114 in. (2.848 to 2.898 mm.) |
| .119 to .121 in. (3.025 to 3.076 mm.) | .114 to .116 in. (2.898 to 2.949 mm.) |
| .121 to .123 in. (3.076 to 3.127 mm.) | .116 to .118 in. (2.949 to 3.000 mm.) |
| .123 to .125 in. (3.127 to 3.18 mm.) | .118 to .120 in. (3.000 to 3.051 mm.) |

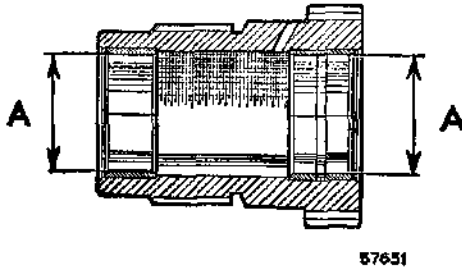

Fig. A.18

A section through the crankshaft primary gear. The bushes (A) must be line-reamed to 1.3775 to 1.3780 in. (34.98 to 35.00 mm.) after fitting (lubricated bushes only)

- (3) Withdraw the race with Service tool 18G 617 A. This operation may also be carried out using Service tool 18G 617 B with the sleeve from the original Service tool 18G 617.

Refitting

- (4) Reverse the removal instructions, driving the race into position with Service tool 18G 617 A.

Section A.19

TRANSMISSION HOUSING

Removing

- (1) Remove the engine from the car (Section A.13).
- (2) Remove the flywheel and clutch (Section A.11), and the flywheel housing (Section A.18).
- (3) Remove the starter motor.
- (4) Lift the engine to separate it from the transmission.

Dismantling

See Section F.1.

Refitting

Reverse the removing instructions.

NOTE.—It is important to insert the short transmission housing to crankcase screw before the crankcase is lowered onto the transmission housing and to screw it in as far as possible before the two housings are finally brought together.

Section A.20

OIL PRESSURE

The differential pressure switch fitted to the oil filter head on later models gives an indication when an oil change is required. If the warning light in the instrument

A.14

panel appears and continues to glow when the engine is running at or above idling speed, both the engine oil and the filter element must be changed as soon as possible within a maximum of the next 300 miles (500 km.).

If the oil pressure falls appreciably, check:

- (1) The quantity of oil in the sump.
- (2) The condition of the pump.
- (3) The union on the suction side of the pump.
- (4) The pick-up filter for sludge.
- (5) The condition of the bearings.

Section A.21

OIL PRESSURE RELIEF VALVE

To examine, unscrew the hexagonal domed nut and remove the folded copper washer, the valve and the spring. Check the length of the spring against the dimension given in 'GENERAL DATA'.

If the valve cup is worn reseal it using metal polish with Service tool 18G 69.

Section A.22

OIL PUMP

Removing

- (1) Remove the engine as detailed in Section A.13.
- (2) Remove the flywheel and clutch assembly and the flywheel housing as detailed in Sections A.11 and A.18.
- (3) Bend back the lock washers, remove the bolts securing the pump to the crankcase, and withdraw the pump.

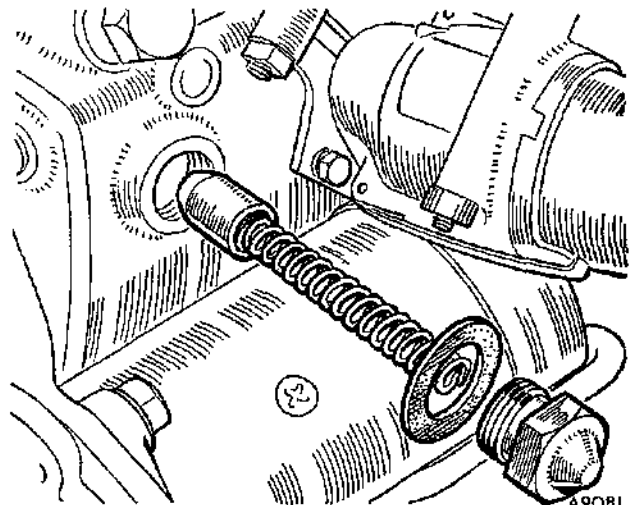

Fig. A.19

The oil pressure relief valve

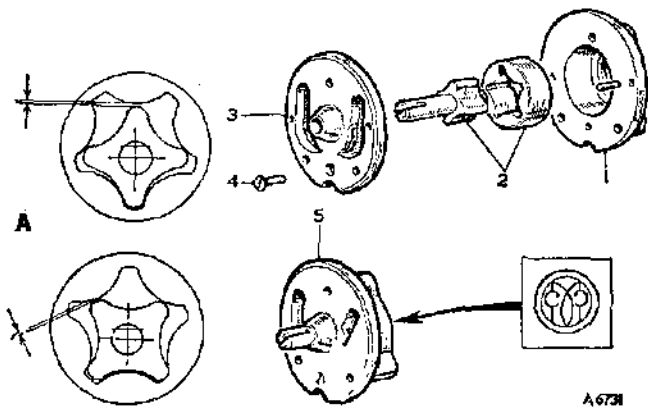

Fig. A.20

Two types of oil pump which may be fitted to this engine. 'A' indicates the lobe positions for checking clearances

Hobourn-Eaton

1. Body.
2. Shaft and rotor.
3. Cover.
4. Screw—cover to body.

Concentric Pumps Ltd.

5. Pump (serviced as an assembly only).

Dismantling and reassembling (Hobourn-Eaton)

- (4) The pump cover is located on the pump body by two dowels and a machine screw. When the screw is removed the pump can be separated for examination and replacement where necessary.
- (5) Install the rotors in the pump body.
- (6) Place a straight-edge across the joint face of the pump body, and measure the clearance between the top face of the rotors and the underside of the straight-edge. The clearance should not exceed .005 in. (.127 mm.). In cases where the clearance is excessive this may be remedied by removing the two cover locating dowels and lapping the joint face of the pump body.
- (7) Install the rotors in the pump body and measure the clearance between the rotor lobes when they are in the position shown in Fig. A.20. If the clearance is in excess of .006 in. (.152 mm.) the rotors must be renewed.
- (8) Reassembly is a reversal of the dismantling procedure.
- (9) After reassembling, check the pump for freedom of action.

Refitting

The refitting of the pump to the cylinder block is a reversal of the removal procedure; ensure that the intake and delivery ports are not obstructed when fitting a new paper joint washer.

Section A.23

CAMSHAFT



Removing

- (1) Remove the engine (Section A.13), the rocker shaft assembly (Section A.5), the push-rods and tappets (Section A.9), and the distributor (Section A.10).
- (2) Unscrew the camshaft locating plate and withdraw the camshaft.
- (3) If the camshaft bearings are worn, remove the flywheel housing and transmission case (Sections A.18 and A.19).

Front liner

Extract worn liners and fit new with Service tool 18G 124 A and adaptor 18G 124 K. Line ream the new liners with Service tools 18G 123 A, 18G 123 AH, 18G 123 AJ.

COOPER

Front and rear liners

Extract worn liners and fit new using Service tools 18G 124 A with adaptor 18G 124 K for the front liner, and adaptor 18G 124 M for the rear liner. Line ream the new liners with Service tools 18G 123 A, 18G 123 BA, 18G 123 AP, 18G 123 AT, 18G 123 AN, and 18G 123 AQ.

Centre liner

Use Service tool 18G 124 A with adaptors 18G 124 K and 18G 124 B to extract the worn liner and fit a new one. Line ream the new liner, using Service tools 18G 123 A, 18G 123 BB, 18G 123 B, and 18G 123 BC.

Refitting

Reverse the dismantling and removing instructions.

Section A.24

PISTONS AND CONNECTING RODS

Pistons and bores are stamped with a number in a diamond and the number on the piston must be the same as that on the bore to which it is fitted.

Oversize pistons are marked on the crown with the oversize; this is the boring dimension and running clearance has been allowed for. Pistons are available in the sizes shown in 'GENERAL DATA'.

Removing

- (1) Remove the engine (Section A.13), the flywheel and clutch (Section A.11), the flywheel housing (Section A.18), the transmission (Section A.19), and the cylinder head (Section A.6).
- (2) Unlock and unscrew the big-end bolts; remove the bearing caps and push the connecting rod assemblies upwards through the bores.

Dismantling

- (3) Lift the rings out of their grooves and slide them off the piston. Always remove and refit rings over the top of the piston.
- (4) Hold the gudgeon pin in a vice between two plugs and unscrew the clamp bolt. Push out the gudgeon pin.

Reassembling

- (5) With the piston and gudgeon pin cold, the pin must be thumb push-fit for three-quarters of its travel and finally be tapped in with a hide mallet. Tighten the clamp bolt to the recommended torque (see 'GENERAL DATA').
- (6) Use new locking plates and tighten the connecting rod bolts to the recommended torque (see 'GENERAL DATA').

NOTE.—The second and third rings are tapered and the upper sides are marked 'T'.

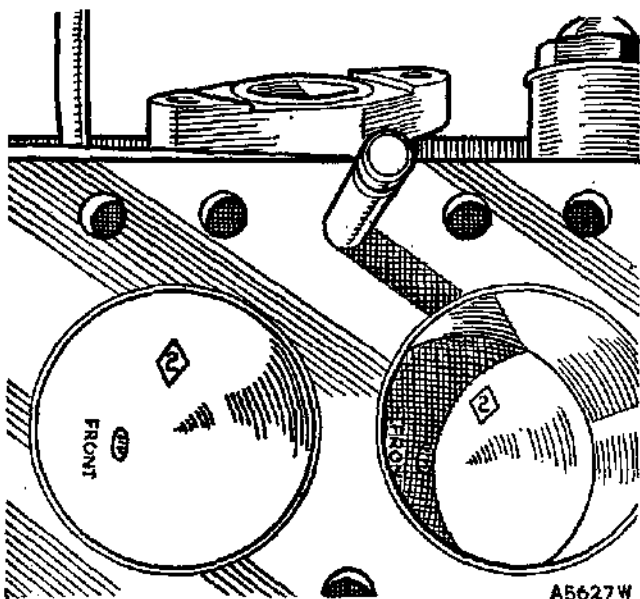

Fig. A.21

The piston markings

COOPER

(998-c.c. engine)

The gudgeon pins are fully floating with a bush in the small end of the connecting rod. The pins are retained in the piston by a circlip at either end. Should damage or wear occur, the gudgeon pin must not be renewed independently of the piston, and the small-end bush must not be renewed on its own, but only as a new connecting rod assembly.

Cooper 'S'

The gudgeon pin is a press fit in the small end of the connecting rod, and the bearing surfaces for the pin are in the piston bosses. The interference fit of the pin in the small end is the only method used to retain the gudgeon pin in its correct relative position. It is essential that the specified interference fit is maintained (see 'GENERAL DATA').

Service tool 18G 1002 must be used to remove and replace the gudgeon pin and great care is necessary to avoid damage to the piston. Mark the piston and pin

before dismantling to ensure that the pin is replaced in the same side of the piston from which it was removed.

Refitting

Reverse the removal instructions, items (1) and (2).

Cylinder liners

Dry liners may be fitted and machining dimensions are given below.

A press capable of 3 tons (3000 kg.) is required to fit new liners, and of 8 tons (8000 kg.) to press out old. The dimensions of the pilots needed are given in Fig. A.22.

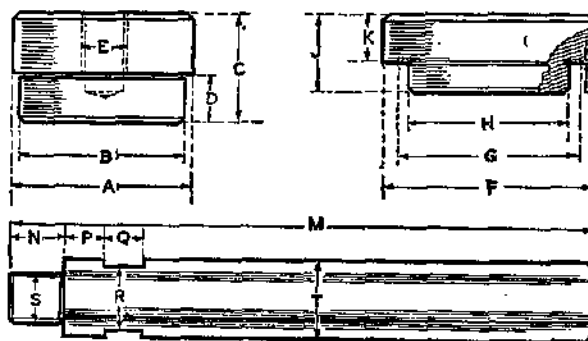

Fig. A.22

Cylinder liner pilots should be made to the above dimensions from case-hardening steel and case-hardened. The pilot extension should be made from 55-ton hardening and tempering steel, hardened in oil, and then tempered at 550° C. (1,020° F.)

Dimensions: pressing-out pilot

| Illustration application | Engine (c.c.) | Inches (in.) | Metric (mm.) | |
|--------------------------------|---------------|-----------------|--------------|-------|
| A. | 848 | 2.578 | 65.48 | |
| | 997 | 2.593 | 65.88 | |
| | 998 | 2.625 | 66.68 | |
| | 1070 | 2.778 | 70.56 | |
| | 1275 | | | |
| B. | 848 | 2.465 | 62.61 | |
| | 997 | 2.452 | 62.28 | |
| | 998 | 2.537 | 64.44 | |
| | 1070 | 2.859 | 72.63 | |
| | 1275 | | | |
| C. | All engines | 1.75 | 44.45 | |
| D. | All engines | .75 | 19.05 | |
| E. | All engines | ¾ B.S.W. Thread | | |
| Dimensions: pressing-out pilot | | | | |
| F. | 848 | 3.00 | 76.20 | |
| | 997 | | 77.79 | |
| | 998 | | 84.14 | |
| | 1070 | | 3.312 | 84.14 |
| | 1275 | | | |
| G. | 848 | 2.625 | 66.68 | |
| | 997 | 2.687 | 69.26 | |
| | 998 | 2.906 | 73.82 | |
| | 1070 | 2.753 | 69.85 | |
| | 1275 | | | |
| H. | 848 | 2.455 | 62.35 | |
| | 997 | 2.430 | 61.72 | |
| | 998 | 2.515 | 63.88 | |
| | 1070 | 2.753 | 69.85 | |
| | 1275 | | | |
| J. | All engines | 1.25 | 31.75 | |
| K. | All engines | .75 | 19.05 | |
| L. | All engines | .015 | .38 | |
| Dimensions: pilot extension | | | | |
| M. | All engines | 10.5 | 317.5 | |
| N. | All engines | .875 | 22.22 | |
| O. | All engines | .625 | 15.87 | |
| Q. | All engines | .625 | 15.87 | |
| R. | All engines | 1.00 | 25.4 | |
| S. | All engines | ¾ B.S.W. thread | | |
| T. | All engines | 1.25 | 31.75 | |

| Engine type | Liner Part No. | Machine bores of cylinder block to this dimension before fitting liner | Outside diameter of liner | Interference fit of liner in cylinder block bore | Machine liner bore to this dimension after fitting |
|---|--------------------|--|---|--|--|
| 848 c.c. | 2A 784 | 2.6035 to 2.604 in. (66.128 to 66.14 mm.) | 2.606 to 2.60675 in. (66.19 to 66.21 mm.) | .002 to .00325 in. (.05 to .08 mm.) | 2.477 to 2.4785 in. (62.915 to 62.954 mm.) |
| 997 c.c. (9F) | 12A 391 | | | | 2.4570 to 2.4585 in. (62.408 to 62.445 mm.) |
| 998 c.c. (9FA) 998 c.c. (99H) | 12G 164 | 2.64075 to 2.64125 in. (67.076 to 67.099 mm.) | 2.64325 to 2.644 in. (67.139 to 67.158 mm.) | | 2.542 to 2.5435 in. (64.571 to 64.608 mm.) |
| 1070 c.c. (9FD/SA) 1275 c.c. (12FA, 12H) | AEG 239 AEG 428 | 2.8750 to 2.8755 in. (73.0 to 73.0012 mm.) | 2.8775 to 2.87825 in. (73.179 to 73.306 mm.) | | 2.779 to 2.7805 in. (70.58 to 70.622 mm.) |

Section A.25

CRANKSHAFT AND MAIN BEARINGS

Removing

- (1) Carry out the operations described in Section A.24, items (1) and (2), and remove the timing cover (Section A.16).
- (2) Check the crankshaft end-float.
- (3) Prise out the circlip and slide the primary gear from the shaft.
- (4) Note that the main bearing caps and crankcase are numbered; withdraw the caps and bearing shells. Do not interchange caps and shells. The bottom halves of the two thrust washers will be removed with the centre bearing cap.
- (5) Lift out the crankshaft with the remaining halves of the thrust washer and the top half-shells of the main bearings.
- (6) Inspect the crankpins and journals, and the bearing shells; regrind the shaft and renew the bearings as necessary. Permissible regrind dimensions and undersize bearing sizes are given in 'GENERAL DATA'. Ensure that all oilway

countersinks are machined to their original dimensions.

- (7) Inspect the thrust washers, and fit new if necessary.
- (8) Thoroughly clean the crankshaft and bearings.

Refitting

Reverse the removal instructions.

Section A.26

CRANKSHAFT AND PRIMARY GEAR

See Section A.18.

Section A.27

CRANKCASE CLOSED-CIRCUIT BREATHING

(When fitted)

Fresh air enters the engine through two holes and a filter in the filler cap on the rocker cover. The air then passes to the crankcase down the push-rod drillings. The crankcase fumes leave the engine through a breather outlet pipe on the front engine side cover. Oil droplets and mist are trapped in an oil separator before the fumes pass through a breather control valve and to the intake manifold, thus providing closed-circuit crankcase breathing.

Testing

With the engine at normal running temperature, run it at idling speed. Remove the oil filler cap. If the valve is functioning correctly the engine speed will increase by approximately 200 r.p.m. as the cap is removed, the change in speed being audibly noticeable. If no change in speed occurs, service the valve as follows.

Servicing

The crankcase breather unit should be serviced at the periods recommended in the Driver's Handbook or the Passport to Service.

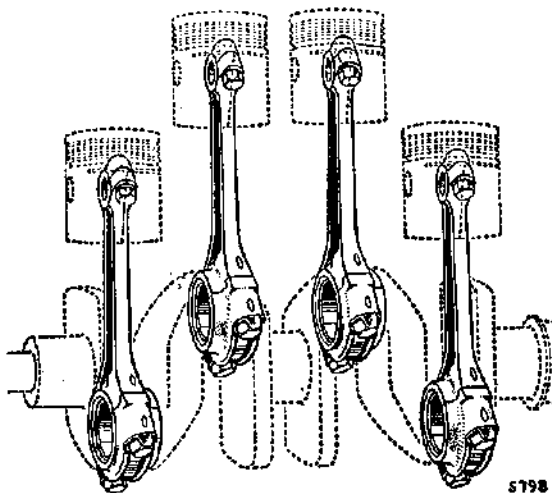

Fig. A.23

The correct assembly of connecting rods to the pistons and crankshaft

Oil filler cap

- (1) Remove the combined oil filler cap and breather filter and fit a replacement at the recommended servicing period.

Breather control valve

- (2) Remove the retaining clip (1) and dismantle the valve.
- (3) Clean all metal parts with solvent (trichlorethylene, fuel, etc.). If deposits are difficult to remove, immerse in boiling water before applying the solvent. Do not use an abrasive.
- (4) Clean the diaphragm (3) with detergent or methylated spirit.
- (5) Replace components showing signs of wear or damage.
- (6) Reassemble the valve, ensuring the metering needle (4) is in the cruciform guides (6) and the diaphragm is seated correctly.

NOTE.—The 1st type valve assembly (without the cruciform guides) is serviced as an assembly.

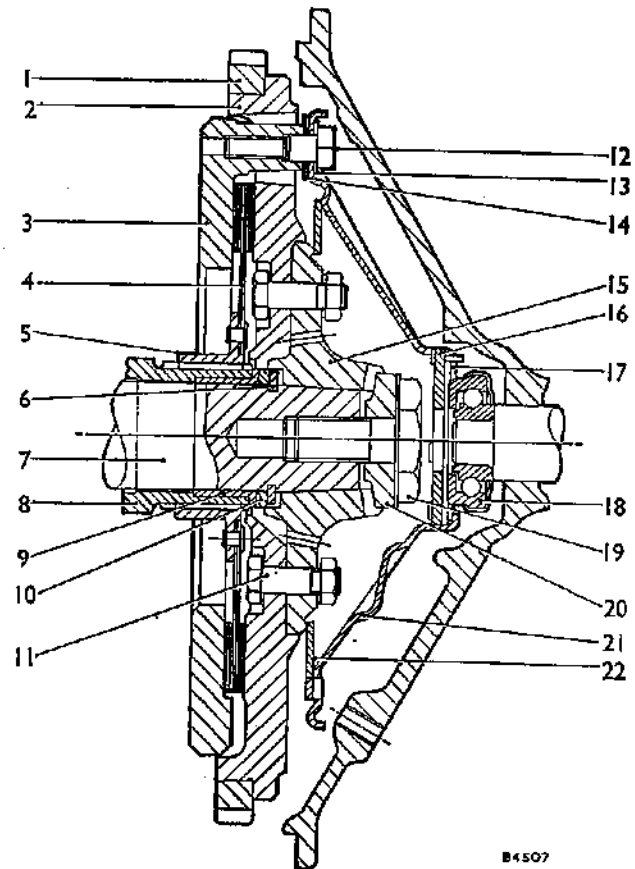

Fig. A.25

A section through the flywheel and diaphragm clutch assembly

- | | |
|-----------------------------|-----------------------------|
| 1. Starter ring. | 12. Driving pin. |
| 2. Flywheel. | 13. Lock washer. |
| 3. Pressure plate. | 14. Driving strap. |
| 4. Driven plate. | 15. Flywheel hub. |
| 5. Driven plate hub. | 16. Thrust plate. |
| 6. Circlip. | 17. Plate retaining spring. |
| 7. Crankshaft. | 18. Thrust bearing. |
| 8. Crankshaft primary gear. | 19. Flywheel screw. |
| 9. Primary gear bearing. | 20. Keyed washer. |
| 10. Thrust washer. | 21. Cover. |
| 11. Flywheel hub bolt. | 22. Diaphragm spring. |

- (4) Slacken the three clutch driving pins evenly to release the spring pressure. Replace the pins as they are removed one at a time with three $\frac{3}{16}$ in. UNF. x 2 in. studs to prevent the pressure plate moving out of alignment.
- (5) Remove the cover and spring assembly.
- (6) Bring Nos. 1 and 4 pistons to T.D.C. to prevent the primary gear 'C' washer falling and being wedged behind the flywheel. With the crankshaft in any other position this could happen and result in damage as the flywheel is withdrawn.
- (7) Knock up the locking washer and remove the flywheel retaining screw using Service tool 18G 587. Remove the keyed washer and insert the plug from Service tool adaptor set 18G 304 N in the screw hole.

Section A.28

FLYWHEEL AND CLUTCH (Diaphragm Spring Clutch)

Removing

- (1) Remove the engine as in Section A.13.
- (2) Remove the clutch cover.
- (3) Mark the pins and the cover to ensure refitting in their original positions.

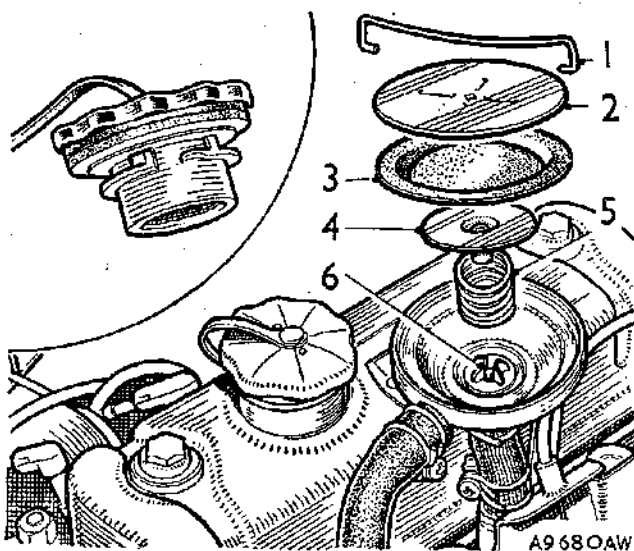

Fig. A.24

The crankcase closed-circuit breathing installation.
(Inset) the oil filler cap filter

- | | |
|--------------------|----------------------|
| 1. Retaining clip. | 4. Metering needle. |
| 2. Cover. | 5. Spring. |
| 3. Diaphragm. | 6. Cruciform guides. |

- (8) Use Service tools 18G 304 with adaptor set 18G 304 N (cadmium-plated) to remove the flywheel.

NOTE.—The black screws from set 18G 304 M must not be used on the diaphragm clutch.

- (9) Screw the three adaptor screws into the flywheel and fit the plate of tool 18G 304 over the screws with the retaining nuts screwed on evenly to keep the plate parallel with the flywheel.
- (10) Screw the centre bolt of adaptor set 18G 304 N through the plate of tool 18G 304. Hold the flywheel from turning and tighten the centre bolt against the adaptor set plug until the flywheel is released from the crankshaft taper.
- (11) Withdraw the flywheel assembly and remove the Service tool.

Inspecting

- (12) Inspect the cover for elongation of the driving pin holes.
- (13) Inspect the driving pins for ridging and wear; fit three new pins if any are worn.
- (14) Inspect the driving straps; fit three new ones if any are worn.

Refitting

- (15) If the driving straps have been removed from the flywheel ensure that the spacing washers are fitted between the straps and the flywheel face.
- (16) Refer to instruction (6).
- (17) Locate the cover and spring assembly with the clutch balance mark 'A' adjacent to the 1/4 timing mark on the flywheel (see Fig. E.2). Fit the driving pins in their original positions, tightening each a turn at a time by diametrical selection to the torque figure given in 'GENERAL DATA'.
Ensure that the dowel portion of the driving pins has entered the holes in each pair of driving straps. Incorrect assembly can cause 'clutch judder'.
- (18) Tighten the flywheel retaining screw to the torque figure given in the 'GENERAL DATA', tap up the locking washer and refit the clutch cover.
- (19) Refit the engine (see Section A.13).

Section A.29

**OIL COOLER
(Cooper 'S')**

Removing

- (1) Remove the front grille, taking care not to lose the spacers used for each securing screw.
- (2) Hold each union on the cooler from turning and disconnect both hoses from the cooler unit.
- (3) Complete removal of both hoses is effected in this manner—holding each union in turn on the oil

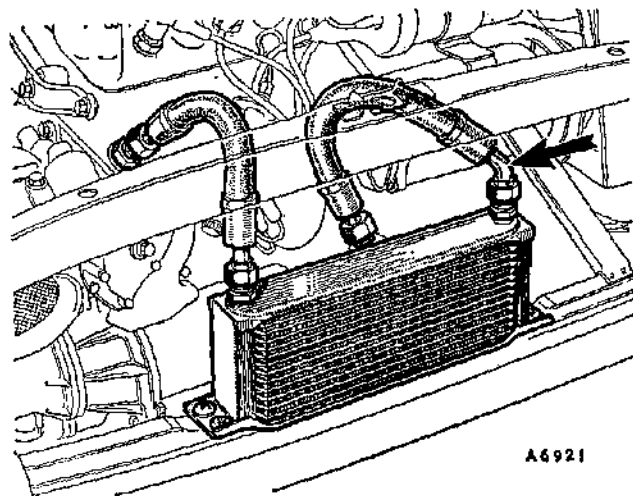

A6921

Fig. A.26

The 13 tube oil cooler fitted to the Cooper 'S'. The arrow indicates the angled hose connection

filler head and the crankcase whilst releasing the hoses.

- (4) Remove the cooler unit securing screws and remove the unit through the grille aperture.

Refitting

- (5) Refit the cooler unit and tighten the securing screws.
- (6) Connect each hose to its respective position on the oil cooler. If replacement hoses are fitted connect the hose with the angled connection to the oil cooler with its other end connected to the filter head. Ensure that the hoses are not under stress from twist—hold each union with a spanner whilst tightening the hose connections.
- (7) Start and run the engine and check for oil leakage.
- (8) Top up the engine oil to the 'MAX' level on the dipstick.
- (9) Refit the front grille, see item (1).

Section A.30

PRIMARY GEAR OIL SEAL REPLACEMENT

Removing

- (1) Remove the engine as in Section A.13.
- (2) Remove the flywheel and clutch, Section A.11 (coil spring type) or Section A.28 (diaphragm spring type).
- (3) Remove the primary gear 'C' washer.
- (4) Screw the centre bolt of Service tool 18G 1068 securely into the crankshaft.
- (5) Pull the primary gear outwards as far as possible. Pass the body of Service tool 18G 1068 over the centre bolt until the groove in the primary gear is visible inside the tool body. Fit the two half collets

of the tool into the groove on the gear and unscrew the winged nut anti-clockwise to withdraw the primary gear and oil seal clear of the housing.

Refitting

- (6) Liberally lubricate the new oil seal, and using protector sleeve Service tool 18G 1043 over the primary gear, fit the oil seal onto the gear.
- (7) Ensure that the primary gear thrust washer is correctly positioned on the crankshaft shoulder and fit the primary gear onto the crankshaft making sure that the gear teeth are starting to engage with the idler gear.
- (8) Check also that the oil seal, whilst contacting the flywheel housing bore, is still seated on the sealing surface of the gear.
- (9) Pass the body of Service tool 18G 1068 over the crankshaft and screw the winged nut down the centre bolt until the base of the tool contacts the lip of the housing bore, whereby the seal is correctly fitted.
- (10) Remove the Service tool and refit the flywheel and clutch.
- (11) Refit the engine as in Section A.13.

Section A.31

FLYWHEEL RETAINING SCREW THREAD

The flywheel retaining screw thread in the end of the crankshaft is not Standard Whitworth but is Whitworth form:

Diameter $\frac{1}{2}$ in. 16 T.P.I. $1\frac{1}{8}$ in. full thread.

If it is found necessary to clean up the thread, the operation must be confined to cleaning up. This thread is highly stressed and must always be up to full size.

Section A.32

GEAR CHANGE REMOTE CONTROL ASSEMBLY

Removing

- (1) Remove the front floor covering, the gear lever knob, and the rubber gaiter.
- (2) From beneath the car, remove the securing screws and nuts from the extension rear support bracket (see Fig. A.12).
- (3) Remove the four bolts securing the extension to the transmission casing and detach the extension.

Dismantling

- (4) Remove the rubber dust cover, and slacken the lever locating pin.
- (5) Remove the screws securing the change speed lever retainer and withdraw the lever, retainer, and spring.
- (6) Lift out the distance piece and spring flange.
- (7) Remove the remote control shaft damper assembly and the screw securing the remote control shaft to the primary shaft lever. Withdraw the shaft and the lever from the housing.

Inspection

Clean and examine all components for wear, and fit new parts as required.

Reassembling

- (8) Reassemble all components in the reverse order of dismantling. Lubricate the operating surfaces of all components with grease.

Refitting

- (9) Reverse the removing procedure, ensuring that the rubber plug is correctly located between the extension and the transmission casing.

GEAR CHANGE REMOTE CONTROL COMPONENTS

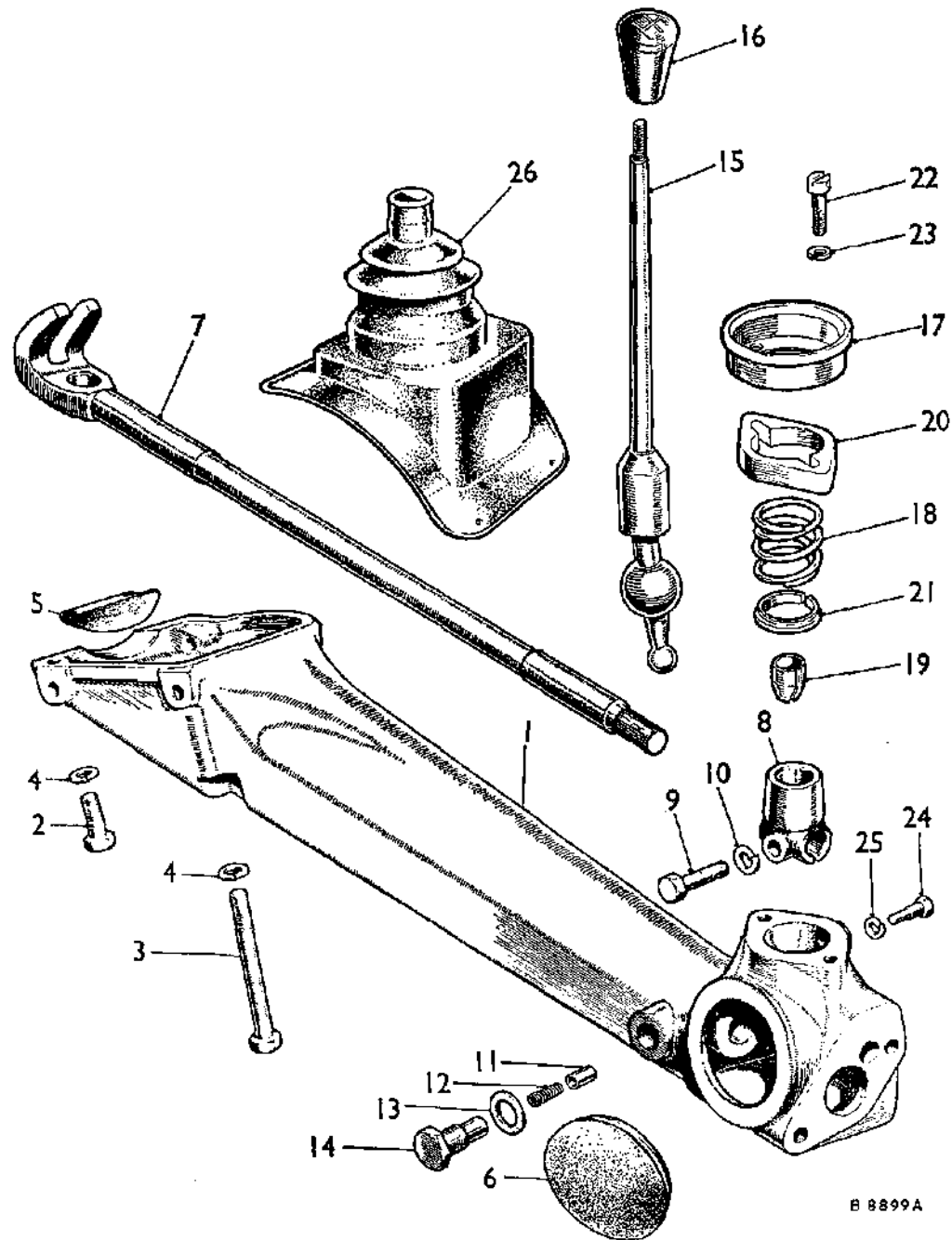

B 8899A

| No. | Description |
|-----|-------------|
|-----|-------------|

- | | |
|-----|-----------------------|
| 1. | Housing. |
| 2. | Securing screw—short. |
| 3. | Securing screw—long. |
| 4. | Spring washers. |
| 5. | Rubber plug. |
| 6. | Rubber dust cover. |
| 7. | Primary shaft. |
| 8. | Primary shaft lever. |
| 9. | Lever—screw. |
| 10. | Spring washer. |
| 11. | Damper plunger. |
| 12. | Plunger spring. |
| 13. | Washer. |

| No. | Description |
|-----|-------------|
|-----|-------------|

- | | |
|-----|----------------------------|
| 14. | Cap nut—spring retainer. |
| 15. | Change speed lever. |
| 16. | Lever knob. |
| 17. | Retainer. |
| 18. | Spring. |
| 19. | Bush—split. |
| 20. | Distance piece. |
| 21. | Flange. |
| 22. | Screw—retainer to housing. |
| 23. | Spring washer. |
| 24. | Locating pin. |
| 25. | Spring washer. |
| 26. | Gaiter—change speed lever. |



SECTION Aa

THE ENGINE

The information given in this Section refers specifically to engines fitted with automatic transmission and must be used in conjunction with Section A

| | <i>Section</i> |
|--|----------------|
| †Camshaft | Aa.9 |
| Converter output gear | Aa.13 |
| Converter housing oil seal replacement | Aa.15 |
| Crankshaft and main bearings | Aa.11 |
| Cylinder liners | Aa.14 |
| Distributor driving spindle | Aa.6 |
| Engine and transmission | Aa.3 |
| Engine mountings | Aa.12 |
| Exhaust system | Aa.5 |
| Lubrication | Aa.1 |
| Oil filter | Aa.2 |
| Oil pump | Aa.8 |
| Pistons and connecting rods | Aa.10 |
| Transmission unit | Aa.4 |
| †Valve timing | Aa.7 |

† These operations must be followed by an exhaust emission check



Section Aa.1

LUBRICATION

Engine/transmission oil level

- (1) Start the engine and run for 1-2 minutes. Switch off the ignition and wait for 1 minute.
- (2) Check the oil level with the dipstick and top up if necessary with the recommended oil to the 'MAX' mark on the dipstick.

Changing the engine/transmission oil

The oil should be drained at the periods recommended in the Driver's Handbook and whilst it is warm and fluid.

- (3) Remove the magnetic drain plug from the right-hand side of the transmission casing and allow the oil to drain. Clean (using non-fluffy cloth) and refit the drain plug.
- (4) Refill the engine/transmission unit with the recommended oil to the 'MAX' mark on the dipstick.
- (5) Carry out items (1) and (2).

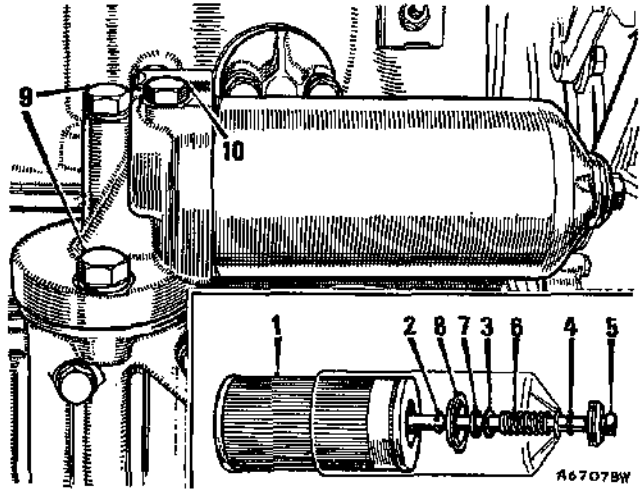

Fig. Aa.1

The engine/automatic transmission oil filter. (Inset) the filter components

- | | |
|--------------------|---------------------------------|
| 1. Filter element. | 6. Spring. |
| 2. Circlip. | 7. Sealing washer. |
| 3. Steel washer. | 8. Sealing plate. |
| 4. Sealing ring. | 9. Filter head retaining bolts. |
| 5. Centre bolt. | 10. Oil pressure check plug. |

Section Aa.2

OIL FILTER

Element replacement

Removing

- (1) Remove the front grille.
- (2) Place a suitable container beneath the oil filter.
- (3) Unscrew the central retaining bolt and remove the bowl and element assembly.

Cleaning

- (4) Thoroughly clean the filter bowl with petrol (fuel) and dry off.
- (5) Wipe the filter head clean and fit a new sealing ring in the filter head recess.

Refitting

- (6) Reassemble the filter bowl with a new element and the internal components fitted in the order shown in Fig. Aa.1. Ensure that the internal seating washer is in good condition and a snug fit on the retaining bolt.
- (7) Refit the filter bowl assembly and tighten the central retaining bolt to the torque figure given in 'GENERAL DATA'.
- (8) Check for oil leakage immediately the engine is started.
- (9) Top up the engine oil level following the instructions in Section Aa.1.
- (10) Refit the front grille.

Aa.2

Filter head and bowl assembly

Removing

- (11) Release the distributor cap.
- (12) Unscrew the filter head retaining bolts and remove the assembly.

NOTE.—The oil filter head to front cover joint washer (with copper inserts) fitted to later units is not interchangeable with those fitted to the earlier units. The two 'O' ring oil seals are not used on the later units (see Fig. Aa.2 for correct location of the later-type joint washer).

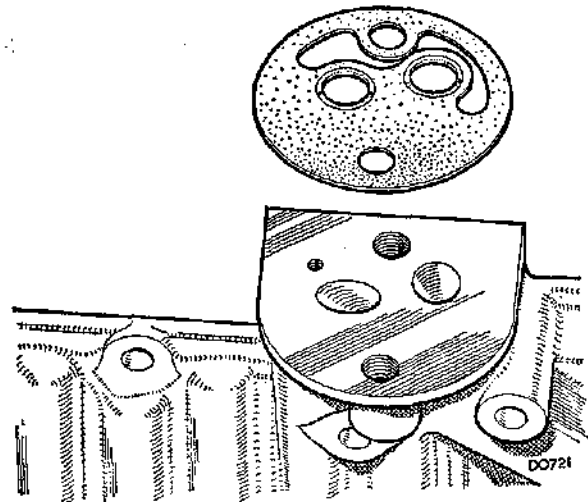
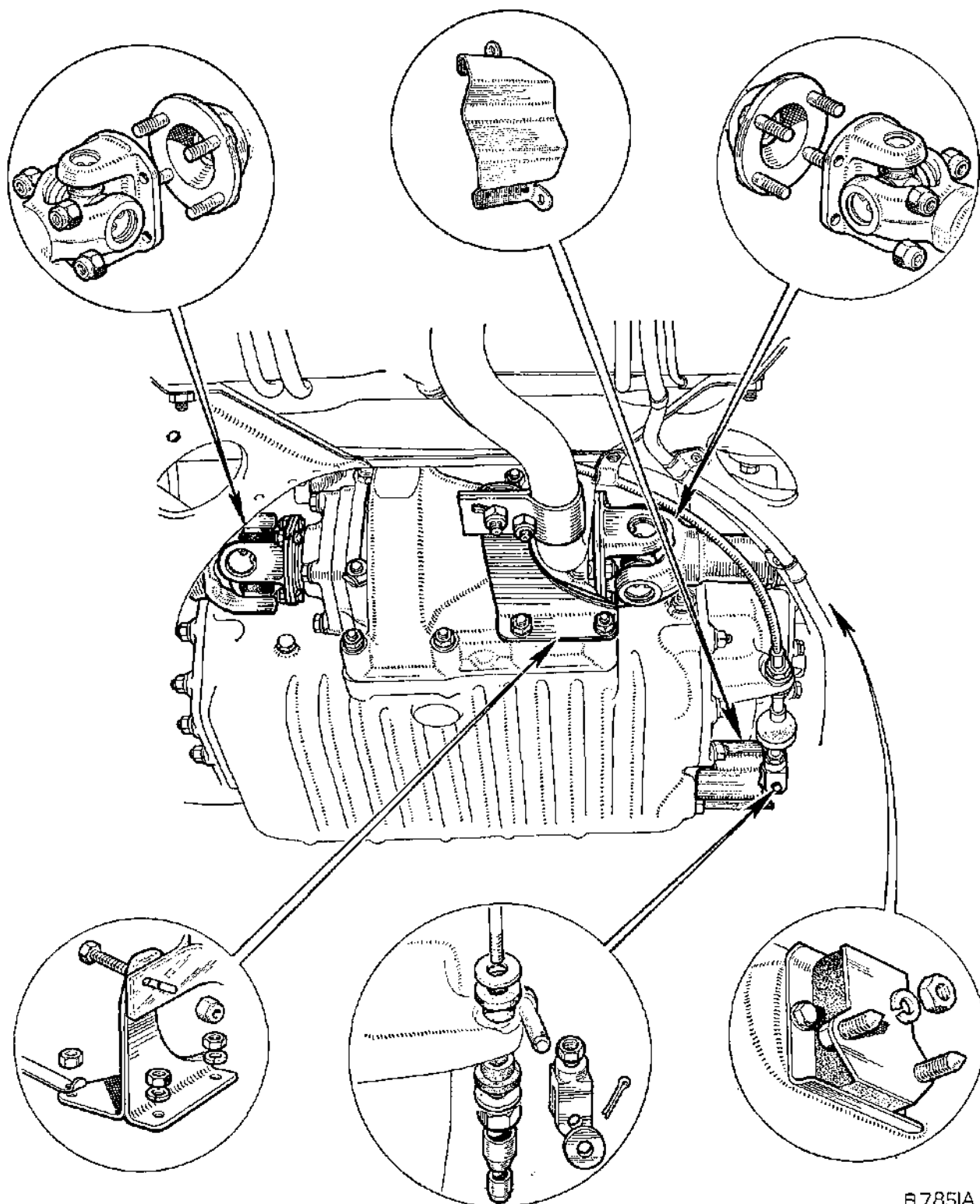

Fig. Aa.2

The correct location of the later-type filter head front cover joint washer



B 7851A

Fig. Aa.3

The main components to be disconnected or removed from below the car before removing the engine and transmission unit

Refitting

(13) Reverse the removal instructions, fitting a new joint washer and seals (if fitted). Tighten the securing bolts to the torque figure in 'GENERAL DATA.'

(14) Carry out items (8) and (9).

Section Aa.2

ENGINE AND TRANSMISSION

Removing

(1) Disconnect the battery earth cable and remove the bonnet.

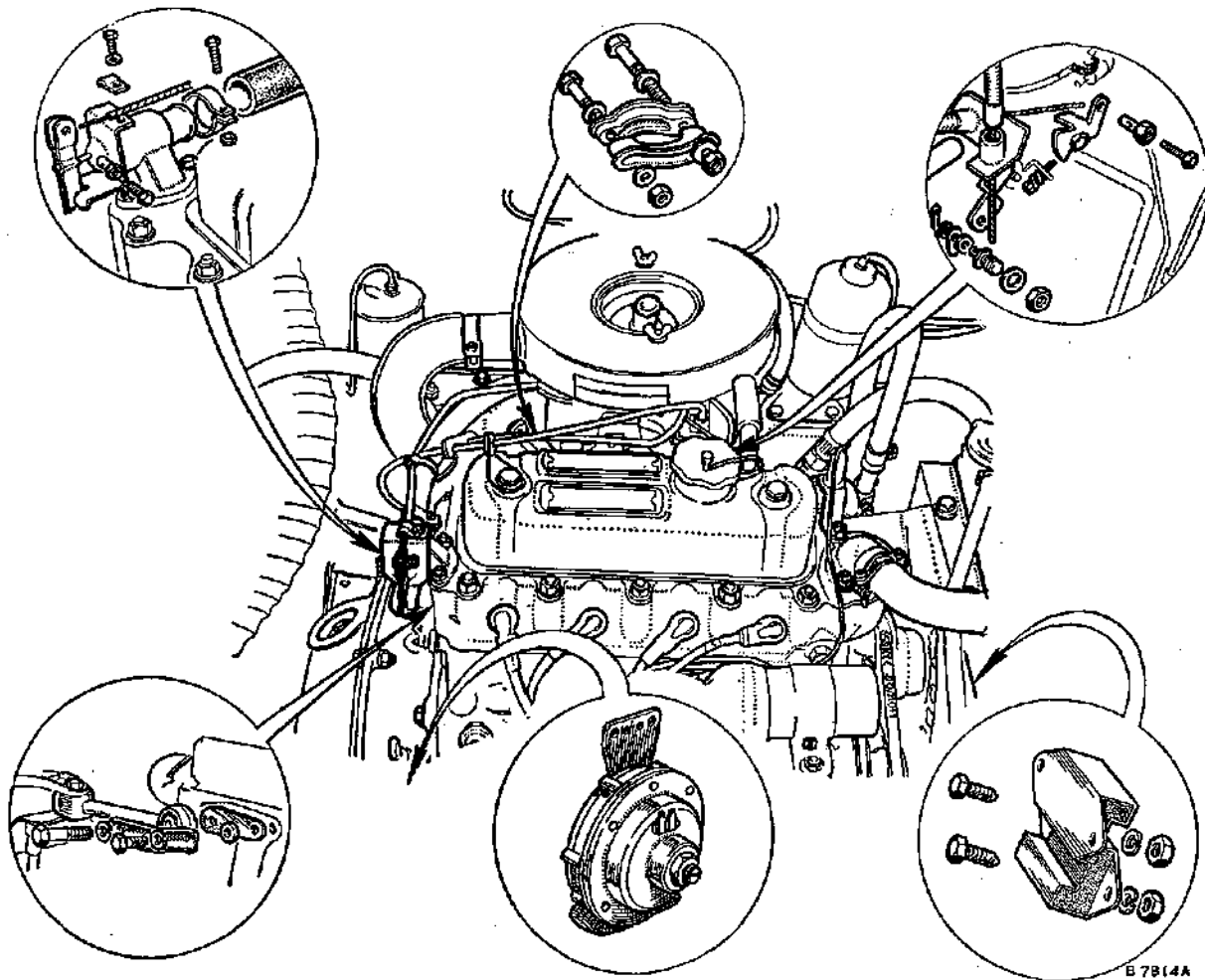

Fig. Aa.4

The main components to be disconnected or removed from above the car before removing the engine and transmission unit

- (2) Raise the front of the car until the wheels are free to rotate and remove the drive shaft flange securing nuts.
- (3) Remove the weather protection cover (if fitted) or pull back the rubber sleeve and disconnect the

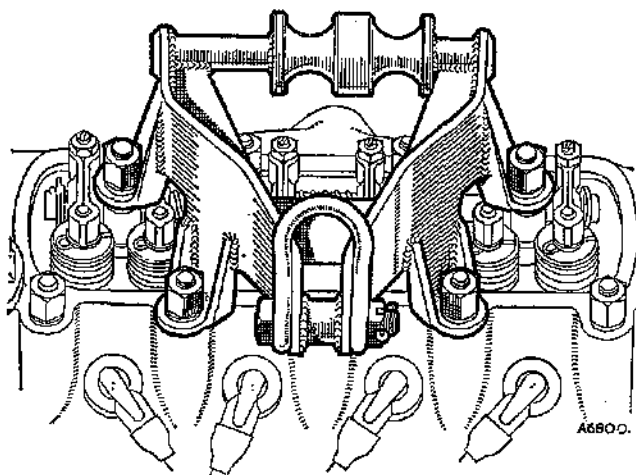

Fig. Aa.5

Use the individual front lifting eye of the attachment to give an angled lift when removing and refitting the power unit

gear selector cable by removing the clevis pin. Slacken the yoke clamp nut and remove the yoke, nut, and rubber ferrules and sleeve. Remove the cable front adjusting nut from the outer cable and pull the cable clear of the transmission.

- (4) Remove the exhaust bracket from the final drive cover. The larger nut is secured by a locking tab (see Fig. Aa.3).
- (5) Drain the cooling system as in Section C.2.
- (6) Disconnect the heater hoses and the water control valve cable. Slacken the fixing clips on the heater fresh air tube connections on the grille and the wing valance and swing the tube clear of the engine bay.
- (7) Disconnect all electrical connections from the engine.
- (8) Remove the distributor cap.
- (9) Remove the air cleaner as in Section Da.1.
- (10) Remove the carburetter as in Section Da.2.
- (11) Disconnect the speedometer cable from the rear of the instrument.
- (12) Disconnect the oil pressure gauge hose.
- (13) Disconnect and remove the horn.

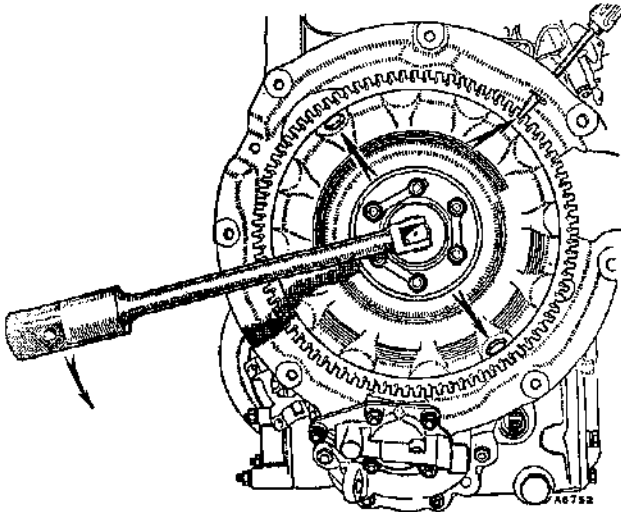

Fig. Aa.6

Removing the converter centre bolt, using Service tool 18G 587. A suitable screwdriver inserted through the converter housing to stop the converter turning, and the converter drain plugs, are indicated by arrows

- (14) Disconnect the exhaust pipe from the manifold and secure the pipe against the bulkhead.
- (15) Disconnect the tie-rod from the cylinder block and swing the rod away from the engine.
- (16) Remove the rocker cover nuts and fit the engine lifting bracket (Fig. Aa.5).
- (17) Remove the set screws securing each engine mounting to the sub-frame.
- (18) Lift the engine sufficiently to release the drive shafts from the driving flanges, and remove the engine/transmission unit from the car.

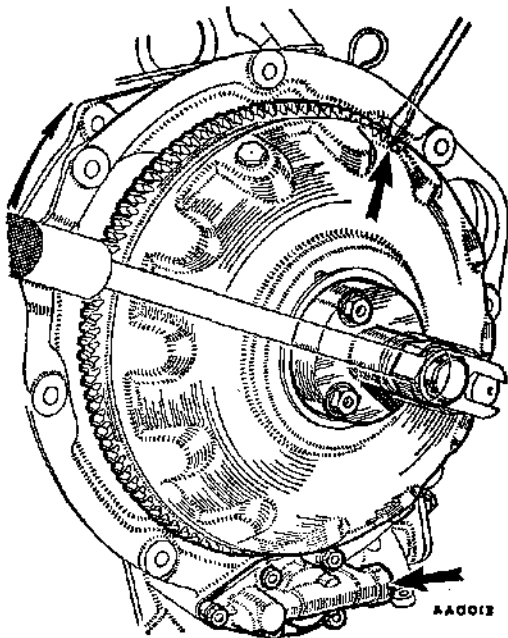

Fig. Aa.7

Removing the converter using Service tool 18G 1086. A screwdriver to stop the converter turning, and the low pressure valve, are indicated by the arrows

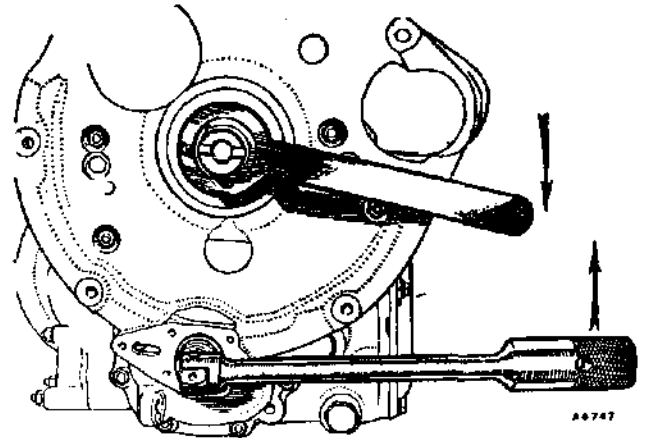

Fig. Aa.8

Using Service tool 18G 1088 to hold the converter output gear when removing the input gear nut

Refitting

- (19) Reverse the removal instructions with particular attention to the following points.
- (20) Lower the engine/transmission unit to a position where the drive shafts can engage the driving flange studs and screw the securing nuts on approximately four threads. Lower the unit completely into the car.
- (21) Adjust the gear selector rod and cable as in Section Fa.2.
- (22) Top up the engine with oil as described in Section Aa.1.

Section Aa.4

TRANSMISSION UNIT

Removing

- (1) Remove the engine and transmission (see Section Aa.3).

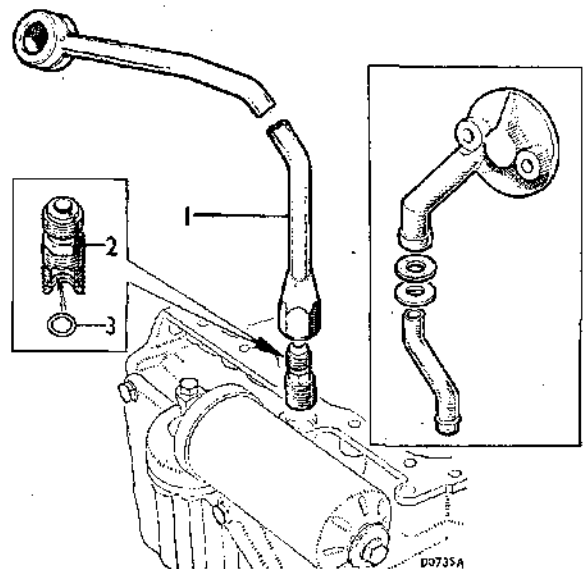

Fig. Aa.9

The engine oil feed pipe (1), adaptor (2) with the internal 'O' ring seal (3). Inset shows the early type pipe assembly

- (2) Remove the radiator mounting bracket from the transmission case.
- (3) Remove the starter motor and converter cover.
- (4) Drain the transmission.
- (5) Knock back the lock washer on the converter centre bolt. Hold the converter from turning with a suitable screwdriver inserted through the hole in the converter housing. Using Service tool 18G 587, remove the centre bolt (Fig. Aa.6).
- (6) Knock back the locking tabs and remove three equally spaced set screws from the converter centre. Ensure that the slot in the end of the crankshaft is horizontal. Using Service tool 18G 1086 with the adaptor correctly positioned, remove the converter (Fig. Aa.7). Remove the Service tool and refit the three screws.
- (7) Remove the low-pressure valve from the converter housing.
- (8) Fit Service tool 18G 1088 onto the converter output gear and remove the input gear self-locking nut (Fig. Aa.8).
- (9) Remove the gear change bell-crank lever clevis pin and nut and lift off the bell-crank lever. Remove the bell-crank lever pivot.
- (10) Fit the nylon protector sleeve Service tool 18G 1098 over the converter output gear.
- (11) Remove the nuts and set screws securing the converter housing to the transmission and lift away the housing. Remove the converter oil outlet pipe from the housing.
- (12) Lever the main oil feed pipe from the transmission and oil pump.

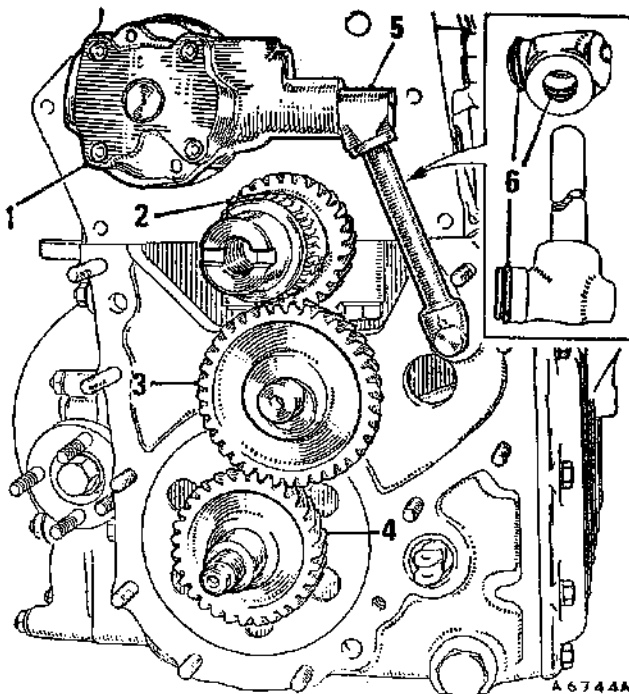

Fig. Aa.10

The converter housing removed showing:

- | | |
|---------------------------|-------------------|
| 1. Main oil pump. | 4. Input gear. |
| 2. Converter output gear. | 5. Oil feed pipe. |
| 3. Idler gear. | 6. Sealing rings. |

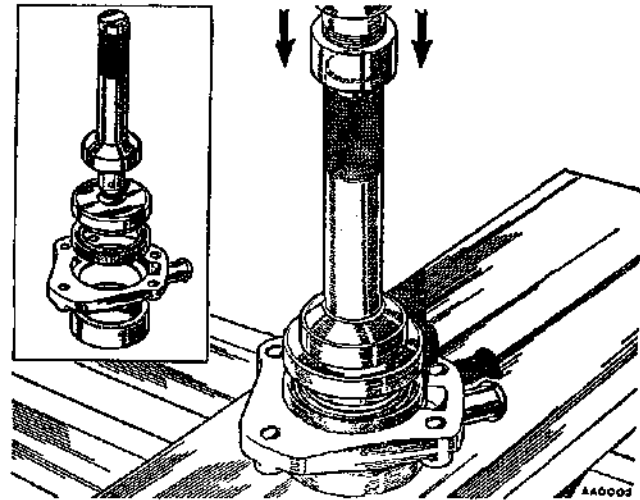

Fig. Aa.11

Replacing the converter output gear oil seal. Pressing the seal in, using Service tools 18G 134 and adaptor 18G 134 CN, with (inset) showing exploded view

- (13) Remove the idler gear, thrust washers, and the converter output gear assembly.
- (14) Remove the oil filter assembly and disconnect the engine oil feed pipe together with, (on early units) its rubber seal and spring washer (see Fig. Aa.9).
- (15) Remove the nuts and set screws securing the engine to the transmission and with suitable lifting equipment lift away the engine from the transmission.

Inspecting

Ensure that the oil rings fitted to the main oil pipe, oil filter, transmission to engine oil feed pipe, and the main oil strainer pipe are in perfect condition. All joint faces must be free from burrs and new joint washers should be used.

Inspect the idler gear bearings and renew if necessary, using Service tool 18G 581 to remove the bearings from the casings. Inspect the input gear bearing and renew if necessary by removing the circlip and pressing the bearing from the housing.

Check the main oil seals and renew if necessary. If it is necessary to renew the converter housing oil seal this operation is detailed in Section Aa.15. To renew the converter output gear oil seal, remove the rear case assembly and carefully remove the seal. Lubricate the new seal and press into the casing, using Service tools 18G 134 and 18G 134 CN (Fig. Aa.11).

Refitting

- (16) Immerse the front main bearing cap moulded rubber oil seal in oil and fit with the lip facing the rear of the engine.
- (17) Fit the rubber sealing ring on to the main oil strainer pipe and fit new gaskets to the transmission case.
- (18) Lower the engine on to the transmission. Ensure that the moulded rubber seal is correctly located. Tighten the set screws and nuts as the transmission is being lowered in position.

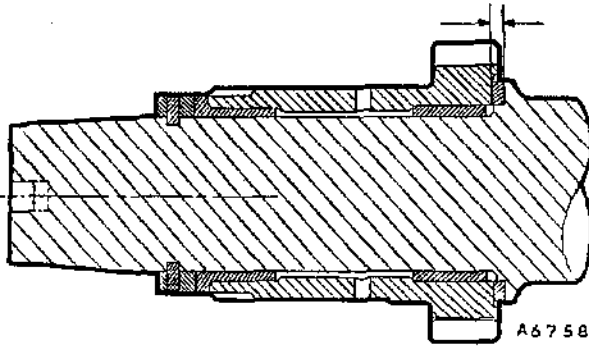

Fig. Aa.12

The converter output gear. Measure the gap indicated and fit the appropriate thrust washer

- (19) Refit the transmission to engine oil feed pipe, with the spring beneath the rubber seal and refit the oil filter assembly.
- (20) Refit the main oil pump to transmission oil pipe.
- (21) Trim off any excess transmission joint from the rear of the unit. Clean the surfaces and fit a new converter housing gasket.
- (22) Refit the converter output gear. When refitting, make certain that the correct running clearance of .0035 to .0065 in. (.089 to .165 mm.) is maintained between the inner thrust washer and the converter output gear. If the clearance is outside these limits, select and fit the appropriate washer from the size range, with the chamfered inner edge of the washer to face the crankshaft.

Converter output gear thrust washers

- .112 to .114 in. (2.848 to 2.898 mm.)
- .114 to .116 in. (2.898 to 2.949 mm.)
- .116 to .118 in. (2.949 to 3.0 mm.)
- .118 to .120 in. (3.0 to 3.051 mm.)

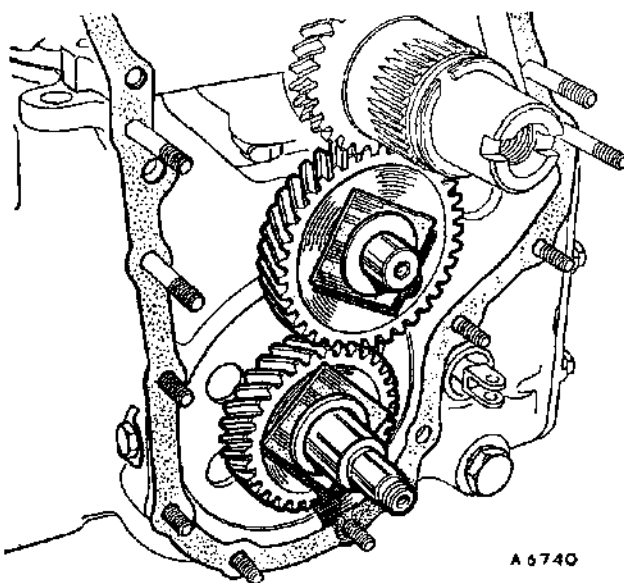

Fig. Aa.13

The idler and input gears fitted with the Service tool, 18G 1089 (two sets of special washers, each set interspersed with a wax washer)

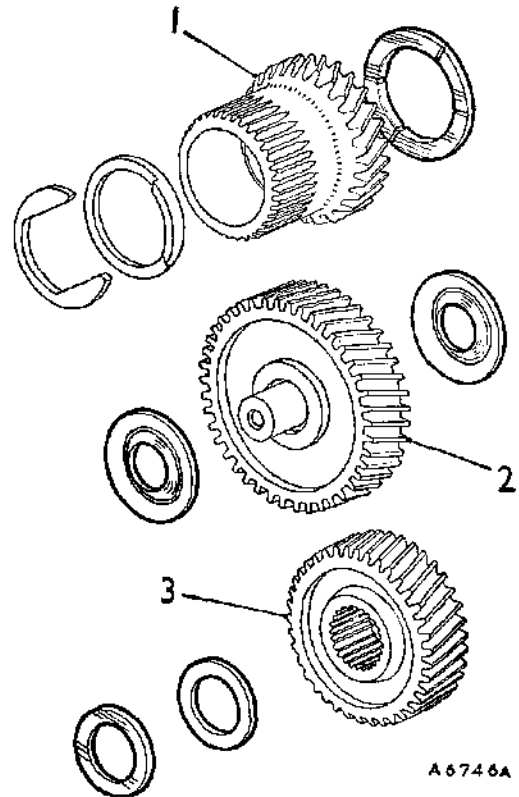

Fig. Aa.14

The converter output (1), idler (2), and input gear (3) with their respective thrust washers

NOTE.—Two types of input gears have been used, those fitted to earlier units have two thrust washers (Fig. Aa.14). The later gear (of increased hub thickness) has a number of thin shims fitted to the outer hub face of the gear for adjustment (see Fig. Aa.19).

Idler and input gear adjustment (Early Models)

- (23) Assemble the idler gear to the transmission with a nominal washer (from the range fitted), on the

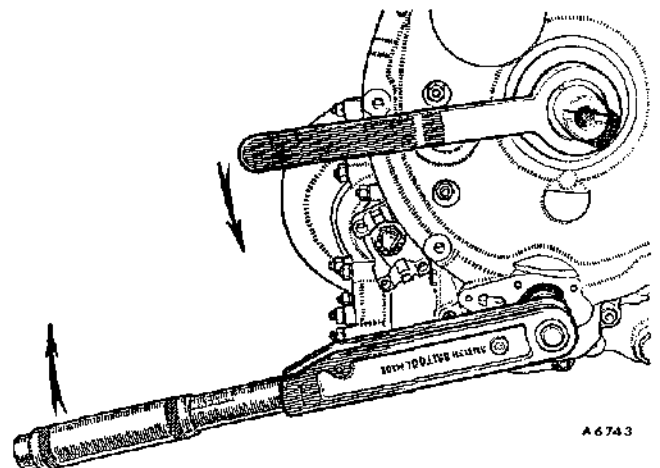

Fig. Aa.15

Using Service tools 18G 1088 to hold the converter output gear and 18G 592 to tighten the input gear nut to the correct torque figure

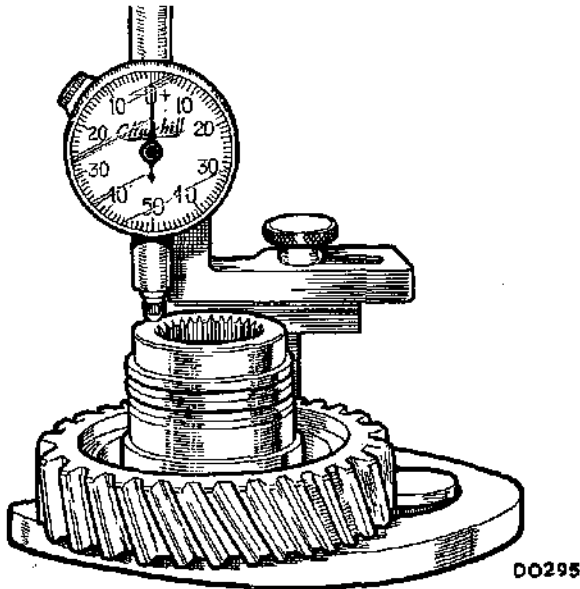

Fig. Aa.16

Using Service tools 18G 191 and 18G 191 A, with the dial test indicator set at zero

transmission side of the idler gear. Assemble Service tool 18G 1089 with a dental wax washer interposed on to the converter housing side of the idler gear. To cut the holes in the wax strip, place the larger washers of 18G 1089 one on either side of the wax, opposite each other, and press together.

- (24) Fit input Service tool 18G 1089 interposed with a dental wax washer (Fig. Aa.13).

NOTE.—If the input gear will not fully mesh with the idler gear, this indicates that the third speed reaction gear thrust washer has become displaced. Therefore it is necessary to remove, dismantle, and reassemble the gear train as detailed in Section Fa.7 (all items except (1)).

- (25) Screw the two pilot bars of Service tool 18G 1043 into the two bottom tapped holes in the crankcase. Fit the nylon protector sleeve Service tool 18G 1098 over the converter output gear and refit the converter housing; tighten into position to the correct torque figure given in 'GENERAL DATA'. The input shaft nut must not be fitted.
- (26) Remove the converter housing.
- (27) Measure the thickness of the idler gear thrust washer plus the thickness of the Service tool 18G 1089 and its dental wax washer. From this figure subtract $\cdot004$ to $\cdot007$ in. ($\cdot102$ to $\cdot178$ mm.) to give the total thickness of the thrust washers to be fitted to provide the correct idler gear end-float.

Idler gear thrust washers

- $\cdot132$ to $\cdot133$ in. (3.35 to 3.37 mm.)
- $\cdot134$ to $\cdot135$ in. (3.40 to 3.42 mm.)
- $\cdot136$ to $\cdot137$ in. (3.45 to 3.47 mm.)
- $\cdot138$ to $\cdot139$ in. (3.50 to 3.53 mm.)

- (28) Measure the thickness of the input gear Service

tool 18G 1089 plus its dental wax washer. Add $\cdot001$ to $\cdot003$ in. ($\cdot025$ to $\cdot076$ mm.) to this figure to give the total thickness of the thrust washers to be fitted to provide the required 'nip' on the input gear bearing.

Input gear thrust washers

- $\cdot128$ to $\cdot130$ in. (3.25 to 3.30 mm.)
- $\cdot132$ to $\cdot134$ in. (3.35 to 3.40 mm.)
- $\cdot140$ to $\cdot142$ in. (3.55 to 3.61 mm.)
- $\cdot148$ to $\cdot150$ in. (3.76 to 3.81 mm.)
- $\cdot152$ to $\cdot154$ in. (3.86 to 3.91 mm.)

- (29) (a) Fit one washer on each side of the idler gear as calculated in item (27).
 (b) Fit two washers to make up the calculated thickness onto the input gear shaft. Both washers must be fitted to the outside of the input gear (see Fig. Aa.14), with the chamfered inside edge of one washer towards the gear.

Idler and input gear adjustment (Later Models)

- (30) Carry out item (23).
 (31) Place the input gear on a surface plate or onto Service tool 18G 191 A and use a dial test indicator gauge, Service tool 18G 191, to take a mean reading. Set the dial gauge to zero as shown in Fig. Aa.16.
 (32) Fit Service tool adaptor 18G 1089 A over the input shaft. Use Service tool 18G 1089/1 to cut a dental wax washer, and fit the wax washer with Service tool 18G 1089/1 over the input shaft (see Fig. Aa.17).
 (33) Carry out items (25) and (26).
 (34) Fit a new converter housing joint washer and ensure that NO shims are sticking to the input gear bearing. Lubricate the oil seal lip, refit the housing and tighten to the torque figure given in

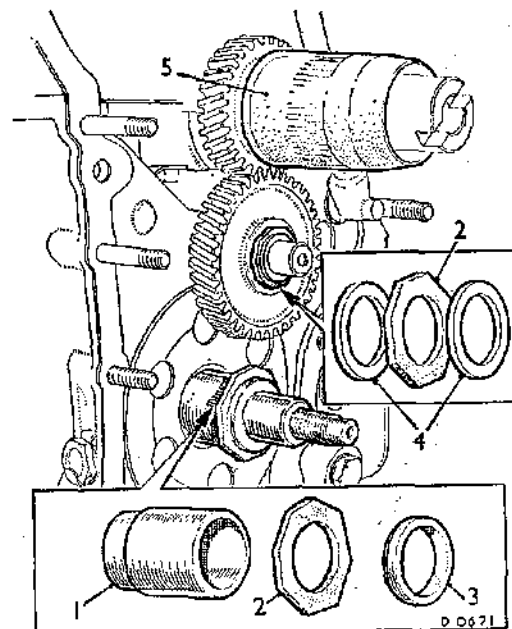

Fig. Aa.17

1. Service tool 18G 1089 A. 4. Service tool 18G 1089 with wax washer interposed.
 2. Wax washer. 5. Service tool 18G 1098.
 3. Service tool 18G 1089/1.

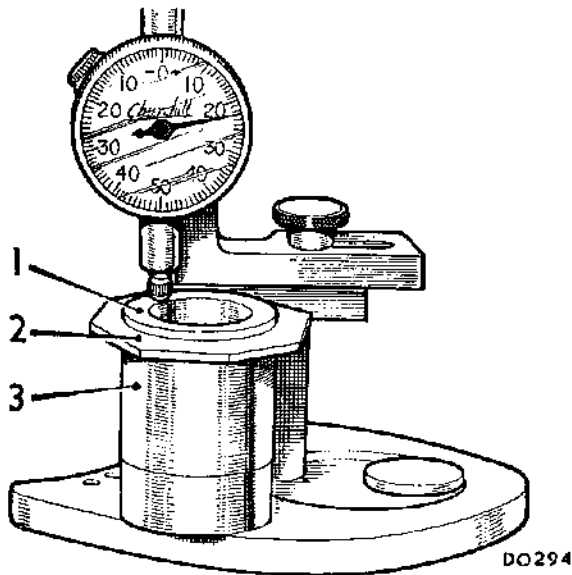

Fig. Aa.18

Measuring the adaptor assembly

1. Service tool 18G 1089/1.
2. Wax washer.
3. Service tool 18G 1089 A.

'GENERAL DATA'. The input shaft nut must not be fitted.

- (35) Remove the converter housing and withdraw the adaptor assembly 18G 1089 A, wax washer, and 18G 1089/1. Substitute this complete assembly for the input gear on the surface plate (see Fig. Aa.18).
- (36) Use the dial test indicator gauge, Service tool 18G 191, and measure the thickness of this assembly (see Fig. Aa.18). The mean reading obtained indicates the total thickness of shims required to eliminate end-float. To this figure add shims to the value of .001 to .003 in. (.025 to .076 mm.) to give the required input bearing preload.

Input gear adjustment shims

- .003 in. (.076 mm.).
- .012 in. (.305 mm.).

- (37) Measure the thickness of the idler gear thrust washer plus the thickness of the Service tool 18G 1089 and its dental wax washer. From this figure subtract .004 to .007 in. (.102 to .178 mm.) to give the total thickness of the thrust washers to be fitted to provide the correct idler gear end-float.

Idler gear thrust washers

- .132 to .133 in. (3.35 to 3.37 mm.)
- .134 to .135 in. (3.40 to 3.42 mm.)
- .136 to .137 in. (3.45 to 3.47 mm.)
- .138 to .139 in. (3.50 to 3.53 mm.)

- (38) (a) Fit the required thickness of shims as calculated in item (36) onto the outside of the input gear (see Fig. Aa.19).
- (b) Fit one washer on each side of the idler gear (see Fig. Aa.19) as calculated in item (37).

Refitting

- (39) Refit and align the converter outlet pipe.

- (40) Discard the converter housing joint washer used during the idler and input gear adjustment operations. Refit the converter housing with a new joint washer, remove the pilot bars of Service tool 18G 1043 and tighten the securing nuts and set screws to the torque figures given in 'GENERAL DATA'.

- (41) Refit the input gear shaft nut and tighten to the correct torque figure (see 'GENERAL DATA'), using Service tools 18G 1088 and 18G 592.

- (42) Remove each pair of bolts in turn from the converter and fit new locking plates. Tighten the bolts to the torque figure given in 'GENERAL DATA', and tap up the locking tabs.

NOTE.—Do not remove all six screws from the converter centre at one time.

- (43) Lubricate the converter oil seal and refit the converter. Refit the washer (offset pegs) and the centre bolt with its lock washer. Tighten the bolt to the correct torque figure (see 'GENERAL DATA') with Service tools 18G 587 and 18G 592 and lock up the lock washer.

- (44) Refit the low pressure valve and gasket.

- (45) Refit the gear selector bell-crank lever, clevis pin, and rubber boot.

- (46) Refit the converter cover, the starter motor, and the rear engine mounting.

- (47) For refitting the engine and transmission to the car (see Section Aa.3).

Section Aa.5

EXHAUST SYSTEM

Removing

- (1) Slacken the exhaust pipe to manifold clamp.

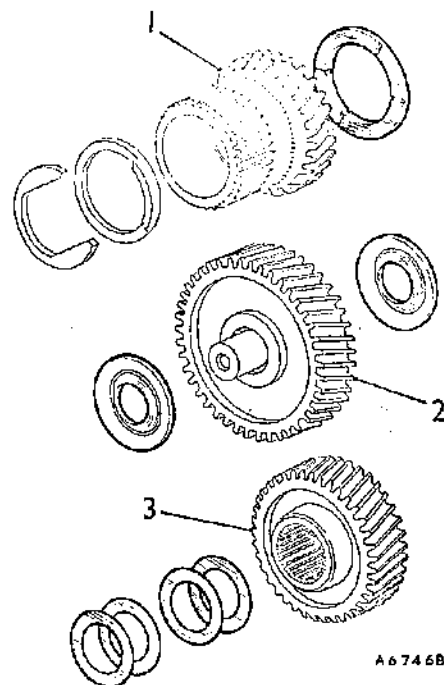

Fig. Aa.19

The converter output (1), idler (2), and input gear (3) with their respective thrust washers and shims

- (2) Release the pipe from the bracket on the final drive casing (Fig. Aa.3) and from the two locations on the rear sub-frame.

Refitting

- (3) Refit the exhaust system to the car with the intermediate and rear support clips loose to allow articulation at the manifold spherical flange.
- (4) Align the pipe flange with the manifold, refit and tighten the manifold clamp.
- (5) Ensure correct alignment of the system and tighten the remaining fixing points.

Section Aa.6**DISTRIBUTOR DRIVING SPINDLE****Removing**

- (1) Remove the distributor and driving spindle as detailed in Section A.10.

Refitting

- (2) Refitting is described in Section A.10 with the following exceptions.
- (3) To rotate the crankshaft, insert a screwdriver through the aperture (adjacent the oil dipstick) on the converter housing, and turn the converter starter ring gear to the position described in Section A.10.
- (4) Check that the 1/4 timing mark on the converter is in line with the pointer on the converter housing (Fig. Ba.1).

Section Aa.7**VALVE TIMING**

- (1) Follow the instructions given in Section A.17 with the following exceptions.
- (2) Rotate the crankshaft as described in Section Aa.6 until the 5° B.T.D.C. timing mark on the converter is opposite the pointer on the converter cover.

Section Aa.8**OIL PUMP****Removing**

- (1) Remove the engine and transmission as detailed in Section Aa.3.
- (2) Remove the converter and converter housing as detailed in Section Aa.4, items (3) to (12).
- (3) Remove the pump securing screws and withdraw the pump.

Dismantling and reassembling

- (4) Follow the instructions given in Section A.22 for the Hobourn-Eaton pump.

Refitting

- (5) Reverse the removal instructions fitting new joint washers as required.

Aa.10

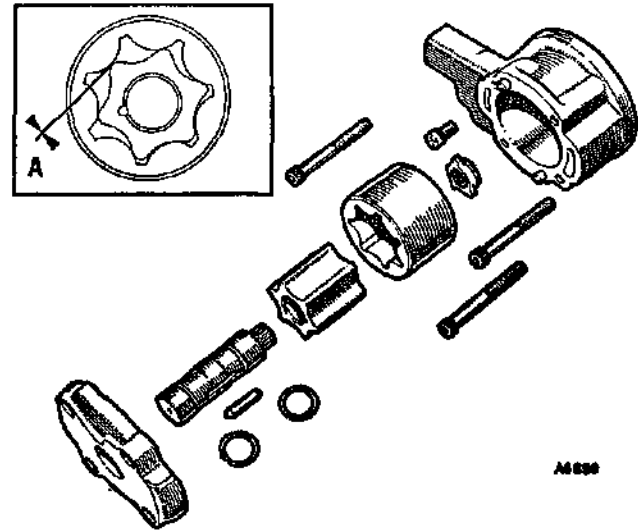

Fig. Aa.20

The oil pump components. A indicates the lobe positions for checking clearances

Section Aa.9**CAMSHAFT**

NOTE.—Extreme care is necessary when removing the camshaft. The oil pump drive coupling may stick by oil adhesion to the camshaft and possibly fall into the transmission unit. Ensure therefore when refitting the camshaft that this drive coupling is fully located on the splined oil pump spindle.

Removing

- (1) Follow the instructions given in Section A.23 with the following exceptions.
- (2) Remove the engine and transmission as detailed in Section Aa.3.
- (3) Should the front camshaft bearing clearance be excessive, a new bearing liner must be fitted and as this will entail line-reaming after fitting, both the converter, converter housing, and the transmission unit must be removed as in Section Aa.4.
- (4) For removing, fitting, and reaming a new liner follow the instructions in Section A.23.

Refitting

- (5) Refitting is a reversal of the removal procedure given in Section A.23.

Section Aa.10**PISTONS AND CONNECTING RODS****Removing**

- (1) Follow the instructions given in Section A.24 with the following exceptions.
- (2) Remove the engine and transmission unit as detailed in Section Aa.3.

- (3) Remove the converter, converter housing, and the transmission unit from the engine as detailed in Section Aa.4.

Refitting

- (4) Refitting is a reversal of the removing procedure (see Sections A.24 and Aa.3-4).

Section Aa.11

CRANKSHAFT AND MAIN BEARINGS

Removing

- (1) Follow the instructions given in Section A.25 with the following exceptions.
- (2) Remove the engine and transmission unit as detailed in Section Aa.3.
- (3) Remove the converter, converter housing, and the transmission unit from the engine as detailed in Section Aa.4.

Refitting

- (4) Follow the refitting instructions for installation of the crankshaft and bearings given in Section A.25
- (5) Carry out the inspection and refitting of the transmission unit as detailed in Section Aa.4.

Section Aa.12

ENGINE MOUNTINGS

Removing

Left-hand mounting

- (1) Follow the instructions in Section A.14.

Right-hand mounting

- (2) Disconnect the battery earth cable.
- (3) Disconnect the electrical connections from the starter solenoid and remove it from the wing valance.
- (4) Disconnect the engine tie-rod from the rear of the cylinder block and the exhaust down pipe from the manifold flange.
- (5) Remove the two nuts and set screws securing the mounting to the sub-frame.
- (6) Lift the rear of the engine sufficiently to remove the securing nuts and bolts from the converter cover and the starter motor. Turn the cover slightly anti-clockwise and remove the cover complete with the engine mounting.
- (7) Unscrew the set screws to release the mounting from the cover.

Refitting

- (8) Refitting is a reversal of the removal procedure.

Section Aa.13

CONVERTER OUTPUT GEAR

Removing

- (1) Remove the engine and transmission as detailed in Section Aa.3.
- (2) Carry out the removing instructions as detailed in Section Aa.4, items (3) to (11) and (13).

Adjusting

- (3) Carry out the instruction given in Section Aa.4, item (22).

Refitting

- (4) Refitting is a reversal of the removal procedure.

Section Aa.14

CYLINDER LINERS

Follow the instructions in Section A.24 with the following exceptions.

- (1) Remove the engine and transmission from the car as detailed in Section Aa.3.
- (2) Remove the transmission unit from the engine as detailed in Section Aa.4.

Section Aa.15

CONVERTER HOUSING OIL SEAL REPLACEMENT

Removing

- (1) Remove the engine from the car as detailed in Section Aa.3.
- (2) Remove the starter motor and converter cover.

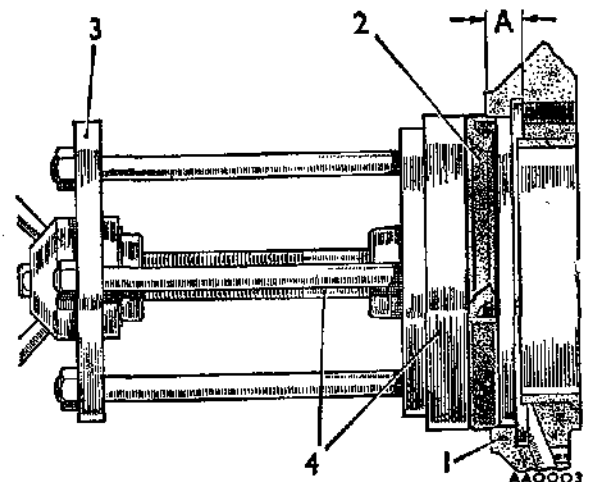

Fig. Aa.21

A section through of fitting the converter housing oil seal. A = the depth measurement to be taken

- | | |
|-----------------------|--|
| 1. Converter housing. | 3. Service tool 18G 1068. |
| 2. Oil seal. | 4. Service tool adaptor set 18G 1068A. |

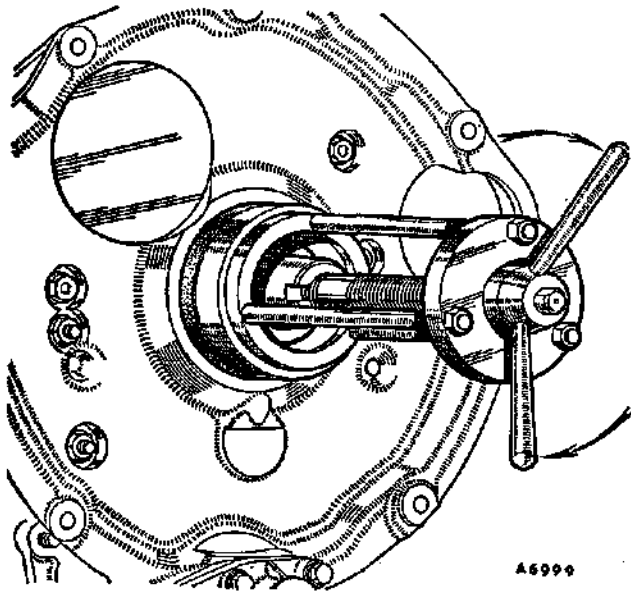

Fig. Aa.22

Fitting the converter output gear oil seal, using Service tool 18G 1068 with adaptor 18G 1068 A

- (3) Remove the converter (Section Aa.4, items (5) and (6)).
- (4) Remove the old seal, using Service tool 18G 1087. Hook the tool into the oil seal groove and tap outwards on the tool, working round the seal until it is removed.

Refitting

The new seal must be fitted to the correct depth in order that the oil drain hole behind the seal remains open.

- (5) Take a depth measurement from any convenient point on the periphery of the housing bore of the front face of the housing to the undercut face (see Fig. Aa.21). This measurement will be approximately $\frac{3}{8}$ in. (9.5 mm.), but should it be more or less than this measurement this must be taken into account and either added to or subtracted from $\frac{3}{8}$ in. (9.5 mm.).

Example: If measurement is $\frac{3}{8}$ in. (9.5 mm.) fit the new seal to be flush with the front face of the converter housing. If measurement is less than $\frac{3}{8}$ in. (9.5 mm.) fit the seal proud of the face by the difference of measurement obtained.

NOTE.—The converter housing face is not machined, therefore, the initial measurement position and that used when fitting a new seal must always be taken from the same position on the housing.

- (6) Screw in the short threaded end of Service tool 18G 1068 A securely into the crankshaft.
- (7) Liberally lubricate the new oil seal.
- (8) Assemble the new seal together with Service tool 18G 1068 into position (see Fig. Aa.22).
- (9) Screw in the wing nut of the tool until the seal is pressed in to the depth of the measurement (see item (5)).
- (10) The remainder is a reversal of the removing procedure.
- (11) Check and top up oil level (Section Aa.1).

SECTION B

THE IGNITION SYSTEM

| | <i>Section</i> |
|------------------------|----------------|
| Capacitor | B.4 |
| †Distributor | B.1 |
| Sparking plugs | B.3 |
| †Timing | B.2 |

† These operations must be followed by an exhaust emission check



Section B.1

DISTRIBUTOR



Removing

- (1) Turn the crankshaft until Nos. 1 and 4 pistons are at T.D.C., the rotor arm is pointing to No. 1 segment in the cap and the points are just breaking.
- (2) Disconnect the low-tension lead from the terminal on the side of the distributor, and the suction advance pipe from the union.
- (3) Take out the two set screws securing the clamp plate and pull out the distributor. Do not loosen the clamp plate pinch bolt.

NOTE.—The position of the driving dog slot. The distributors on later models have an 'O' ring oil seal fitted to the mounting shank.

Dismantling

Contact breaker only

- (4) Remove the rotor arm and the slotted nylon low-tension terminal insulator from the distributor body.
- (5) Take out the two screws, ease up the contact breaker plate and unhook the flexible actuating link.

Distributor assembly

- (6) Pull off the rotor arm.
- (7) Unscrew the nut and remove the nut and washer from the moving contact anchor pin.
- (8) Withdraw the insulating sleeve from the capacitor and low-tension connectors. Lift off the moving contact and the large insulating washer from the anchor pin.
- (9) Take out the screw and spring and flat washers securing the fixed contact plate and remove the plate.
- (10) Remove the capacitor.
- (11) Take out the two screws securing the base plate (one also carries the earth lead) and lift out the base plate.
- (12) Unhook the flexible actuating link connecting the diaphragm of the suction advance unit.
- (13) Take out the cam retaining screw, disconnect the toggle springs and remove the cam.

Note the relative positions of the drive slot in the cam spindle and the offset driving dog to ensure that the timing is not 180° out when the cam spindle is re-engaged with the centrifugal weights during reassembly.

- (14) Lift out the centrifugal weights.
- (15) Remove the circlip, adjusting nut and springs, and withdraw the suction advance unit.
- (16) Drive out the pin passing through the collar of the driving dog member at the lower end of the spindle, withdraw the spindle from the body.

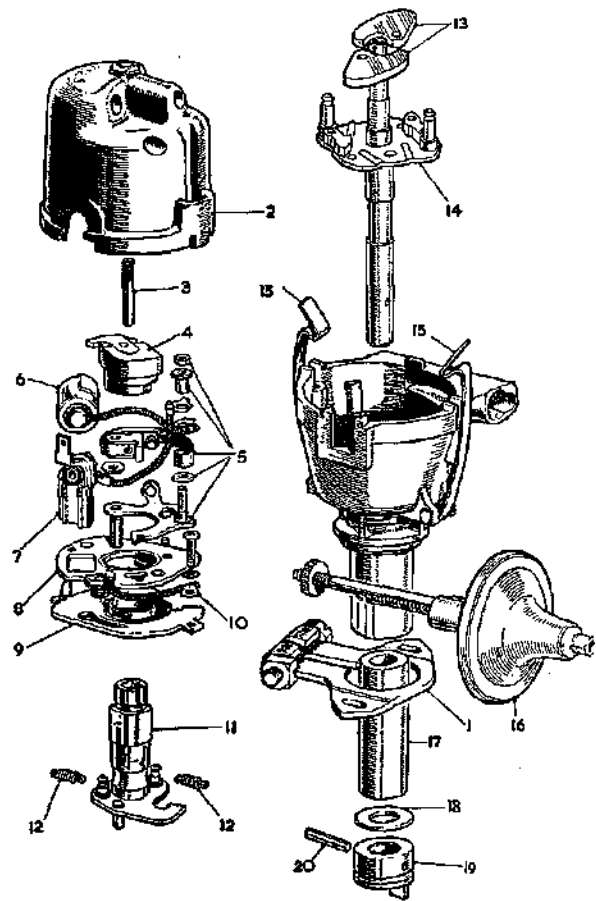

Fig. B.1

The components of the distributor

- | | |
|-------------------------------------|--------------------------------|
| 1. Clamping plate. | 12. Automatic advance springs. |
| 2. Moulded cap. | 13. Weight assembly. |
| 3. Brush and spring. | 14. Shaft and action plate. |
| 4. Rotor arm. | 15. Cap-retaining clips. |
| 5. Contacts (set). | 16. Vacuum unit. |
| 6. Capacitor. | 17. Bush. |
| 7. Terminal and lead (low-tension). | 18. Thrust washer. |
| 8. Moving contact breaker plate. | 19. Driving dog. |
| 9. Contact breaker base plate. | 20. Taper pin. |
| 10. Earth lead. | |
| 11. Cam assembly. | |

NOTE.—The Cooper 'S' distributor is not fitted with a suction advance device; therefore items (12) and (15) are not applicable.

Inspecting

- (17) Clean the cap and examine for cracks and signs of tracking; renew if necessary.
- (18) Make sure that the carbon brush moves freely in the cap.
- (19) If the metal electrode on the rotor arm is slack or badly burned, fit a new arm.
- (20) Clean the contact breaker points, or fit a new set if they are badly pitted or burnt.
- (21) Check the fit of the movable contact arm, balance weights, cam assembly, and the shaft in the body; fit new where necessary.

NOTE.—Before fitting a new shaft bush immerse it in engine oil for 24 hours, or for two hours in oil heated to 100° C. (212° F.).

Reassembling

- (22) Reverse the dismantling procedure with the following additional work.
- (23) Refers to items (13) and (14). Lubricate with thin engine oil.
- (24) Refers to item (14). When engaging the cam driving pins with the centrifugal weights, make sure they are in their original positions. When seen from above the small offset of the driving dog must be on the right, and the driving slot for the rotor arm in the six o'clock position.
- (25) Check the oil sealing ring on the mounting shank and fit a new seal if necessary (later models only).
- (26) Refers to item (15). Turn the suction control adjusting nut to the half-way position when refitting.

If the clamp bolt has been slackened for any reason, when refitting the distributor to the engine, to ensure correct alignment, screw in the two clamp plate securing screws finger-tight only, tighten the clamp bolt to the correct torque tightness (see 'GENERAL DATA'), then tighten the securing screws fully.

Section B.2

TIMING



If the distributor has been removed, refer to Section A.10.

Setting

- (1) Remove the sparking plugs and the flywheel inspection cover.
- (2) Turn the manual adjuster to the central position.

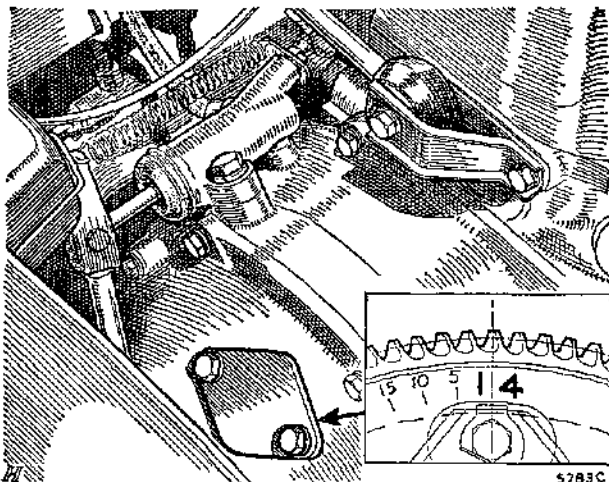

Fig. B.2

The timing marks on the flywheel, and the indicator, may be seen with the aid of a mirror after removing the inspection plate on the clutch cover

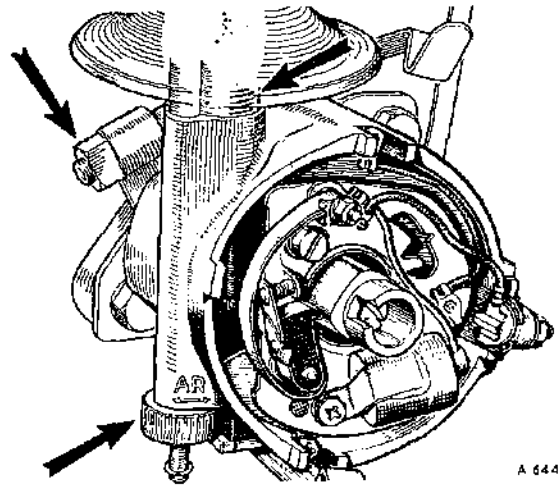

Fig. B.3

The distributor clamp plate pinch-bolt and vernier scale. The lower arrow indicates the ignition firing point adjusting nut

- (3) Remove the distributor cap.
- (4) Adjust the gap at the points.
- (5) Turn the flywheel in the direction of engine rotation until the correct timing mark on the flywheel is opposite the indicator. The No. 1 piston is on compression and the rotor pointing to No. 1 segment in the cap. For the correct timing mark see 'GENERAL DATA'.
- (6) With the indicator opposite the correct timing mark, the distributor contact points are just about to break.
- (7) Turn the knurled adjuster towards 'R' if the points break before, and towards 'A' if they break after the timing mark. Each graduation on the adjuster spindle is equal to about 5° of flywheel movement and 55 clicks on the adjuster.
- (8) If further adjustment is required, slacken the distributor clamp bolt and turn the distributor clockwise to advance and anti-clockwise to retard the firing point.
- (9) Tighten the clamp and check.

Checking points opening—electrical

Connect a 12-volt battery and bulb in parallel with the contact points: when the bulb lights the points have just opened.

Stroboscopic check

If this method is used do not run the engine fast enough to operate the centrifugal weights.

When the vacuum advance take-off is directly from the induction manifold disconnect it before checking.

Section B.3

SPARKING PLUGS

Remove, clean, and adjust the sparking plugs at the recommended intervals and if they are suspected to be the cause of poor performance:

- (1) Blow all dirt from around the plugs before unscrewing them; remove the plugs and gaskets.
- (2) Clean the plugs with abrasive blasting equipment.
- (3) Adjust the gaps with a Champion Sparking Plug Tool, bending the side electrode only.
- (4) Clean the gasket seatings in the cylinder head and screw the plugs with gaskets into position. If the original gaskets have been compressed to less than half their thickness, fit new. Tighten the plugs to the recommended torque (see 'GENERAL DATA').

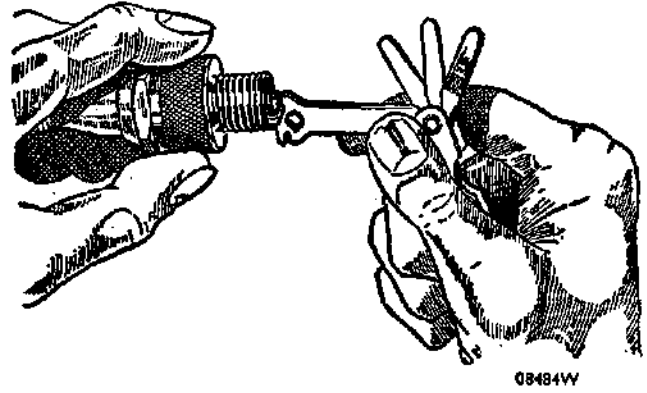

Fig. B.4

Reset the gap, using a Champion special gap setting tool shown above

Section B.4

CAPACITOR

If the capacitor is suspected check by substitution of a new one and note the difference, if any, in the engine running.

SECTION Ba

THE IGNITION SYSTEM

The information in this Section refers specifically to engines fitted with automatic transmission and must be used in conjunction with Section B

| | <i>Section</i> |
|------------------------------|----------------|
| †Timing the ignition | Ba.1 |

† These operations must be followed by an exhaust emission check



Section Ba.1

TIMING THE IGNITION



- (1) Follow the instructions given in Section B.2 with the following exceptions.
- (2) To rotate the crankshaft, insert a screwdriver through the aperture (adjacent to the oil dipstick) on the converter housing, and turn the starter ring gear in the direction of engine rotation to the position described in Section B.2, item (5).
- (3) The three timing marks can be seen on the converter (Fig. Ba.1) after removal of the rubber grommet on the converter end cover.

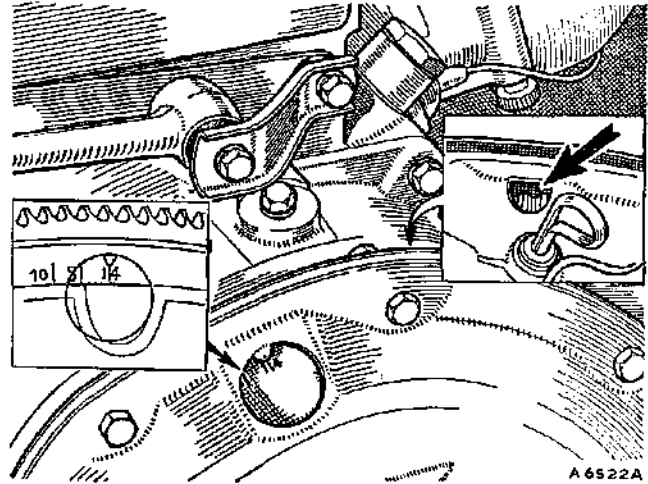

Fig. Ba.1

The timing marks on the converter, T.D.C. position is indicated by the 1/4 shown inset; 5° and 10° marks are also provided. The hole in the converter housing (shown inset) used for inserting a suitable tool to turn the converter

SECTION C

THE COOLING SYSTEM

| | <i>Section</i> |
|---------------------------|----------------|
| Fan belt | C.2 |
| Frost precautions | C.4 |
| Radiator | C.1 |
| Thermostat | C.5 |
| Water pump | C.3 |

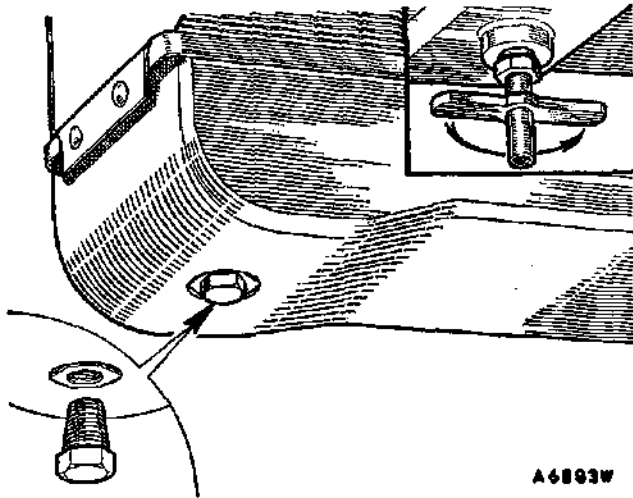

Fig. C.1

The radiator drain plug or tap

Section C.1

RADIATOR

The cooling system is under considerable pressure when hot.

Take off the cap slowly, turning it anti-clockwise until you feel the tongues engage the lobes on the end of the filler cam. Allow the pressure to fall before turning further and removing the cap.

Draining

- (1) Drain the system, using the taps (or plugs if fitted) at the base of the radiator and at the rear of the cylinder block.

Flushing

- (2) Flush the system periodically by running water through until it comes out clear. If the radiator is excessively furred up, remove it and flush through in the reverse direction (in through the bottom hose connection) using the reverse flush adaptor 18G 187 with a 1 in. (25 mm.) hose.

Filling

- (3) Close the drain tap(s) or refit the drain plug(s). Fill to the level indicator in the radiator top tank. Use only the recommended anti-freeze when necessary.

Removing

- (4) Remove the bonnet and drain the system.
- (5) Remove the cowling upper support bracket and the two bolts securing the lower support bracket to the engine mounting.

C.2

One-piece cowling

- (6) Disconnect the top hose and completely remove the lower.
- (7) Take out the four screws securing the radiator to the cowling and lift off the radiator and cowling.

Two-piece cowling

- (8) Disconnect the top and bottom hoses.
- (9) Take out the six screws securing the radiator to the cowling and remove the top half of the cowling.
- (10) Bend the lower hose to the outside of the cowling and lift out the radiator.

COOPER

Removing

- (11) Drain the system and remove the bonnet and grille.
- (12) Disconnect the top hose.
- (13) Detach the upper mounting bracket.
- (14) Remove the top half of the cowling.
- (15) Take out the two screws in the bottom half of the cowling securing the lower mounting bracket.
- (16) Disconnect the heater hose from the bottom radiator hose and the radiator hose.
- (17) Remove the fan and lift out the radiator.

Refitting

Reverse the removal instructions.

Section C.2

FAN BELT

Removing

- (1) Slacken the dynamo pivot and adjusting link bolts.
- (2) Lift the dynamo and run the belt off the crankshaft pulley.
- (3) Manoeuvre the belt between the fan blades and the right-hand top of the cowling.

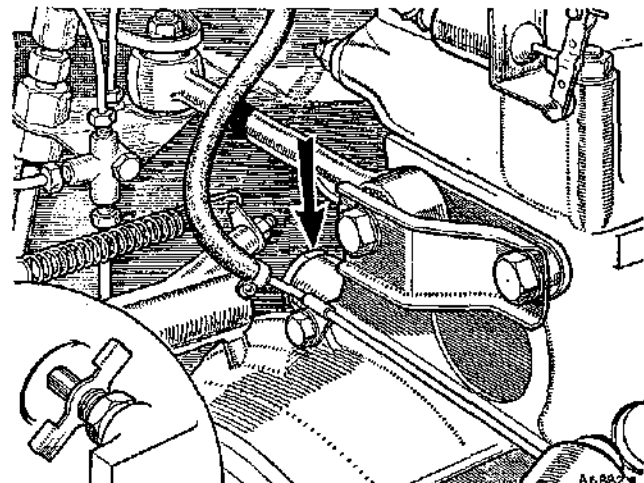

Fig. C.2

The cylinder block drain plug or tap

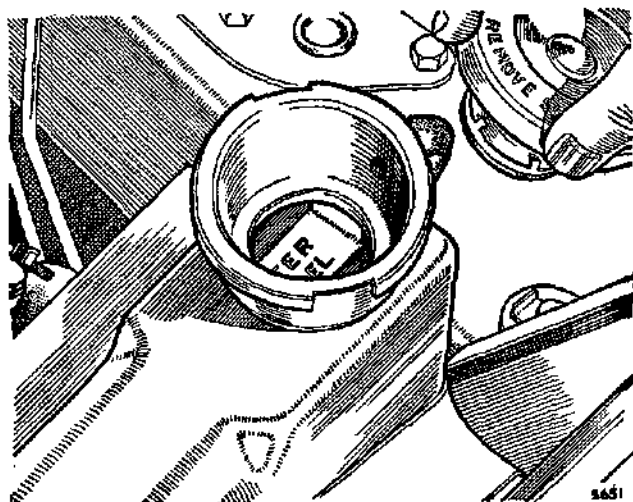

Fig. C.3

The filler cap of the sealed cooling system removed, showing the water level indicator

- (4) If the fan is 16-bladed, feed the belt between individual blade tips and the cut-out in the cowl flange.

Refitting

Reverse the removing instructions.

Adjusting

Adjust the tension by moving the dynamo so that the belt can be moved 1 in. (25 mm.) at the centre of its longest run.

Section C.3

WATER PUMP

Removing

- (1) Drain the system and remove the radiator.
- (2) Disconnect the hose from the water pump inlet connection and slacken the top clip of the by-pass hose.
- (3) Unscrew four set screws and lift off the pump.

Dismantling

- (4) Withdraw the bearing locating wire through the hole in the top of the pump body.
- (5) Tap the spindle backwards to extract the spindle and bearing assembly.
- (6) Pull the vane from the spindle and remove the seal.

Reassembling

Reverse the dismantling instructions.

Refitting

Reverse the removing instructions.

Section C.4

FROST PRECAUTIONS

Damage due to freezing can be prevented by draining the system when the car is not in use, or by the addition of anti-freeze. When a heater is fitted anti-freeze must be used as there is no provision for satisfactorily draining the heater matrix.

Use only an anti-freeze of the ethylene glycol type: Bluecol is recommended. Also, any anti-freeze to B.S.3151 or B.S.3152 is approved.

Quantity of anti-freeze required

| Anti-freeze % | Commences to freeze | | Frozen solid | | Amount of anti-freeze | | |
|---------------|---------------------|------|--------------|------|-----------------------|-----------|--------|
| | ° C. | ° F. | ° C. | ° F. | Pts. | U.S. Pts. | Litres |
| 25 | -13 | 9 | -26 | -15 | 1½ | 1.8 | .85 |
| 33½ | -19 | -2 | -36 | -33 | 2 | 2.5 | 1.18 |
| 50 | -36 | -33 | -48 | -53 | 3½ | 3.75 | 1.8 |

Section C.5

THERMOSTAT

Removing

- (1) Drain the cooling system (Section C.1.).
- (2) Disconnect the top hose and remove the cowl upper support bracket.
- (3) Remove the securing nuts and spring washers from the thermostat cover and the cover from its studs.
- (4) Remove the paper joint washer and lift out the thermostat.

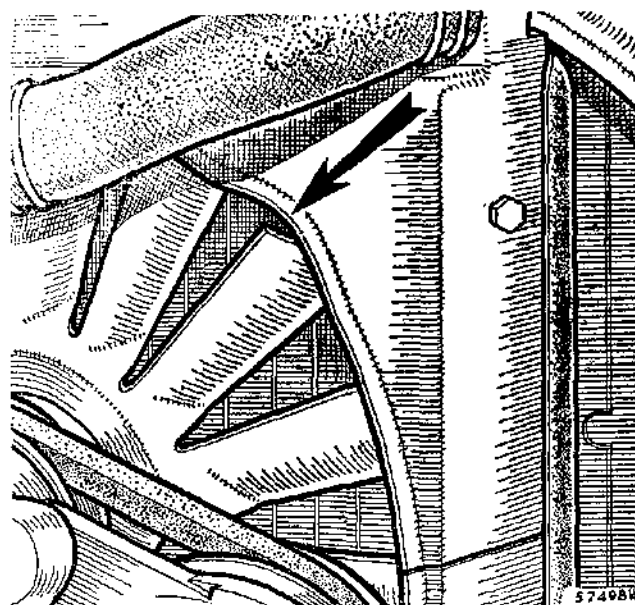

Fig. C.4

Turn the fan blades to the position indicated where the fan belt can be extracted through the recess provided in the radiator cowl

Testing

- (5) Test the thermostat opening temperature by immersing it in water and raising the temperature of the water to the thermostat opening temperature as given under 'GENERAL DATA'. If the thermostat valve fails to open or sticks in the fully open position, fit a new one; do not attempt to repair it.

Refitting

- (6) Installation of the thermostat assembly is the reverse of the removal procedure. Fit a new joint washer if the existing one is damaged.
- (7) A wax-element-type thermostat together with a modified thermostat water outlet cover is fitted to later vehicles.
- (8) When refitting this type of thermostat it is essential that the threaded stem faces upwards.

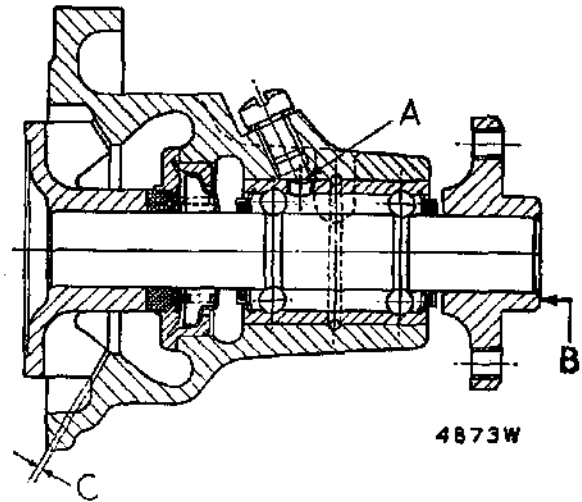
**Fig. C.5**

A section through the water pump showing the location of the components. When assembled, the hole (A) in the bearing must coincide with the lubricating hole in the water pump and the face of the hub (B) must be flush with the end of the spindle. The clearance at (C) must be .020 to .030 in. (.508 to .762 mm.)

SECTION D

THE FUEL SYSTEM

| | <i>Section</i> |
|--------------------------------------|----------------|
| †Air cleaner | D.7 |
| †Carburettor | D.6 |
| Fuel pump (Moke) | D.8 |
| Fuel pump: | |
| Type PD | D.3 |
| Type SP | D.4 |
| Testing | D.5 |
| Fuel tank | D.1 |
| Fuel tank (Moke) | D.9 |
| Tank gauge unit | D.2 |
| Twin fuel tanks (Cooper 'S') | D.10 |

†These operations must be followed by an exhaust emission check



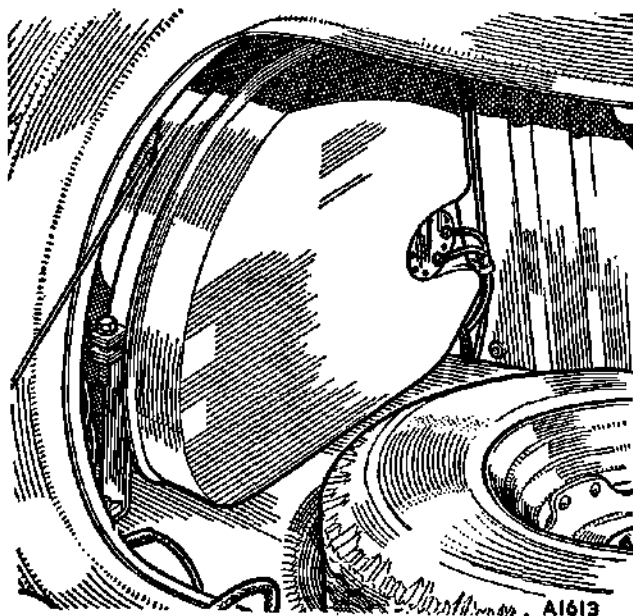

Fig. D.1

The fuel tank located on the left-hand side of the luggage compartment

Section D.1

FUEL TANK

Removing

- (1) Unscrew the tank drain plug (when fitted) approximately three turns, otherwise, disconnect the flexible hose from the pump and drain the tank.
- (2) Take off the filler cap, disconnect the lead from the gauge unit and unscrew the bolt from the securing strap. Release the vent pipe clip and remove the tank from the luggage compartment, at the same time drawing the fuel and vent pipes through the floor. Note the locating plate fitted below the tank.

VAN, PICK-UP, AND LATER TRAVELLER

- (3) Remove the six flange screws and spacers and lower the tank.

TRAVELLER (EARLY MODELS)

- (4) Remove the trim liner from the body above the tank, and the metal finishers from the rear seat squab support.
- (5) Lift out the luggage platform, disconnect the battery and ease the trim panel away from the tank.
- (6) Drain the tank and disconnect the drain and fuel delivery pipes. Take off the filler cap.
- (7) Disconnect the fuel gauge lead and pull the breather pipe from the tank.
- (8) Unscrew the support bracket screws and lift the tank from the vehicle.

Refitting

SALOON

- (9) Reverse the removal instructions. Note that the vent pipe passes through the same hole as the wiring harness. The seal between the drain pipe housing and the body must be watertight. Refit the locating strip before the strap is tightened.

VAN, PICK-UP, AND TRAVELLER

Reverse the removal instructions.

Section D.2

TANK GAUGE UNIT

Removing

- (1) Disconnect the battery earth cable and the electrical connection from the fuel gauge tank unit.
- (2) Ensure that the fuel level in the tank is below that of the fuel gauge unit aperture.
- (3) Remove the six securing screws to remove the unit. On later models remove the tank unit locking ring with Service tool 18G 1001 and carefully remove the unit from the tank.

Refitting

- (4) When refitting the gauge unit, use a new joint washer coated with a suitable sealing compound.
- (5) On later models fit a new rubber sealing ring and tighten the unit locking ring with the Service tool.

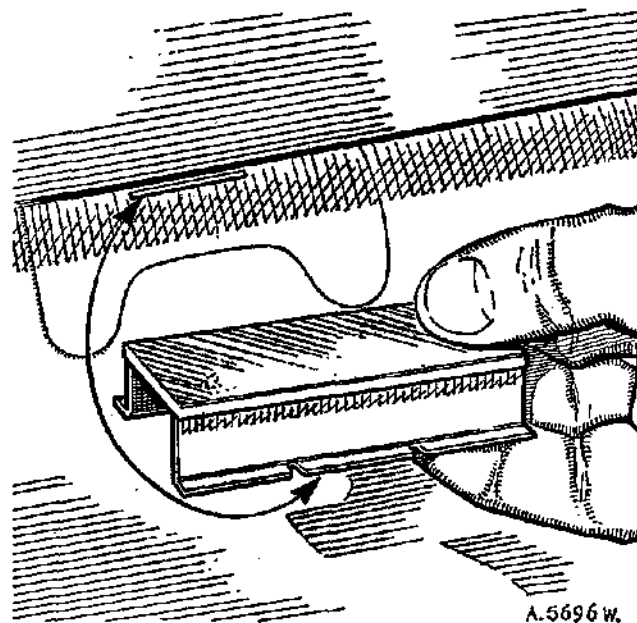

Fig. D.2

The tongue of the fuel tank locating plate must be secured in the slot in the luggage compartment floor

Section D.3

FUEL PUMP—TYPE PD

Apart from cleaning the filter and contact points, no servicing is possible; if the pump fails a new one must be fitted.

Removing

- (1) Disconnect the leads, slacken the clamp screws, and pull off the fuel pipes. Unscrew the bracket screws and remove the pump and bracket.

Cleaning the filter

- (2) Remove the pump and take off the bottom cover plate. Extract the filter and clean it with a brush and petrol (fuel). Fit a new cover gasket.

Points

- (3) Lift off the top cover and clean the points by drawing a piece of clean paper between them.
- (4) Check that the points make good contact and that the gap between the end of the upper blade and its stop face is not less than .015 in. (.4 mm.).

Refitting

- (5) Reverse the removing instructions.

Section D.4

FUEL PUMP—TYPE SP AND AUF 201

The pump is mounted on the lower left-hand flange of the rear sub-frame.

Removing

- (1) Disconnect the battery, the pump leads, and both hoses.
- (2) Unscrew the nut securing the pump clamp to the bracket and lift off the pump and clamp.

Refitting

- (3) Reverse the removing instructions.

Dismantling

- (4) Screw the inlet nozzle from the pump body and withdraw the filter and fibre washer.
- (5) Unscrew the six screws securing the coil housing to the body, separate the housing, diaphragm, and body.
- (6) Withdraw the retainer screw, retainer, and valves.
- (7) Unscrew the armature from the inner rocker trunnion and remove the brass rollers, feed spring and impact washer from the armature.
- (8) Remove the terminal nut, Lucar connector and washer from the terminal screw and take off the bakelite cap.

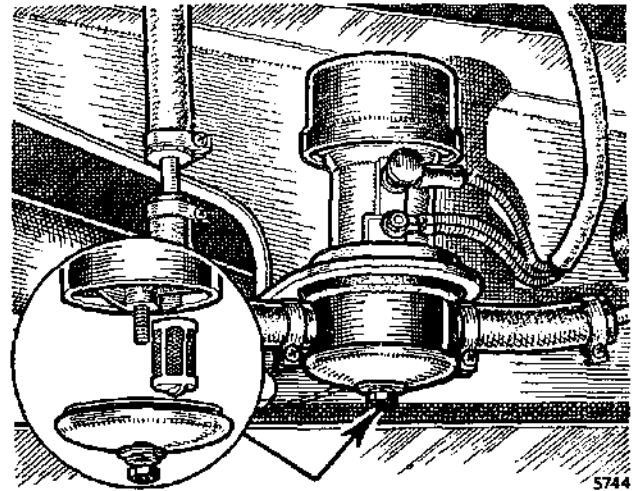

Fig. D.3

The PD-type fuel pump

- (9) Unscrew the spring blade securing screw and disconnect the coil lead. Remove the terminal screw retaining nut; cut the lead washer.
- (10) Unscrew the two pedestal retaining screws and disconnect the braided copper earth lead.
- (11) Remove the remaining coil lead from the terminal screw and the screw from the pedestal.
- (12) Push the rocker pivot pin from the pedestal and remove the rocker assembly. Do not remove the toggle spring.

Inspecting

- (13) Clean and examine all parts.
- (14) Check the feed spring; test figures are given in 'GENERAL DATA'.
- (15) Check the condition of the valves and springs.
- (16) If the points are pitted or burnt, fit a new rocker assembly.

Assembling

- (17) Refit the valves and retainer.
- (18) Screw the nozzle, with a new washer, into the body.
- (19) Refit the rocker assembly.
- (20) Refit the terminal screw, spring washer, short coil lead, new lead washer and nut.
- (21) Connect the braided copper earth lead to the nearest pedestal screw with the tag next to the head of the screw; screw the pedestal to the coil housing.
- (22) Refit the remaining coil lead and the spring blade. The blade must bear against the small rib on the top face of the pedestal, and the tag of the solenoid lead must be on top of the blade.
- (23) Adjust the spring blade so that the points are making good contact and the points on the blade wipe over the centre line of the other points when the rocker arm is moved up and down. Tighten the spring blade screw.

THE AUF 201 and SP FUEL PUMP COMPONENTS

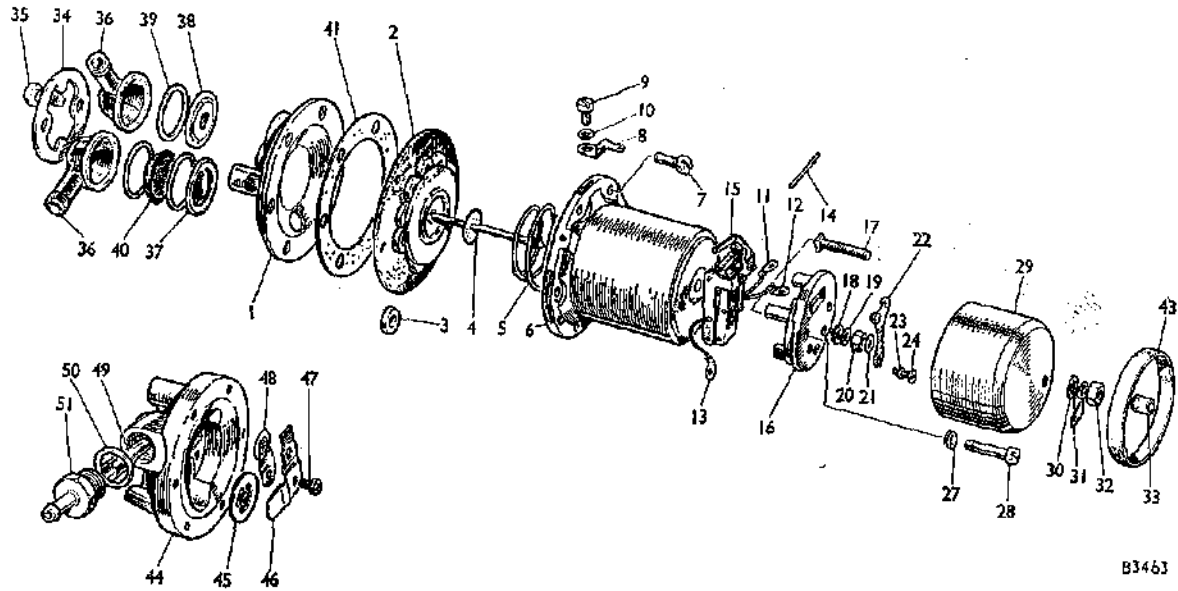

B3463

| No. | Description | No. | Description | No. | Description |
|-----|---------------------------------|-----|-----------------------------|-----|---------------------------|
| 1. | Pump body (AUF 201 only). | 17. | Terminal stud. | 35. | Set screw. |
| 2. | Diaphragm and spindle assembly. | 18. | Spring washer. | 36. | Inlet and outlet nozzles. |
| 3. | Armature centralizing roller. | 19. | Lead washer. | 37. | Inlet valve. |
| 4. | Impact washer. | 20. | Terminal nut. | 38. | Outlet valve. |
| 5. | Armature spring. | 21. | End-cover seal washer. | 39. | Sealing washer. |
| 6. | Coil housing. | 22. | Contact blade. | 40. | Filter. |
| 7. | Set screw. | 23. | Washer. | 41. | Gasket. |
| 8. | Earth connector. | 24. | Contact blade screw. | 43. | Sealing band. |
| 9. | Set screw. | 27. | Spring washer. | 44. | Pump body. |
| 10. | Spring washer. | 28. | Screw. | 45. | Outlet valve. |
| 11. | Terminal tag. | 29. | End-cover. | 46. | Valve retainer. |
| 12. | Terminal tag. | 30. | Shakeproof washer. | 47. | Screw. |
| 13. | Earth tag. | 31. | Connector. | 48. | Inlet valve. |
| 14. | Rocker pivot pin. | 32. | Nut. | 49. | Filter. |
| 15. | Rocker mechanism. | 33. | Insulating sleeve. | 50. | Washer. |
| 16. | Pedestal. | 34. | Clamp plate (AUF 201 only). | 51. | Inlet nozzle. |

AUF 201 only.

SP type only.

- (24) The free end of the spring blade must be deflected away from the rib on the pedestal so that a gap exists between the under-side of the blade and the rib.
- (25) Refit the impact washer and the spring to the armature spindle, pass the spindle through the centre of the coil housing and screw it into the trunnion on the inner rocker.
- (26) Screw the spindle into the trunnion until a steady pressure on the armature just fails to cause the outer rocker to snap over. Then unscrew the spindle seven holes (for body and coil housing screws).
- (27) Position the rollers, fit the body to the coil housing and tighten the securing screws.
- (28) Refit the bakelite cap, spring washers, Lucar connector, nut and terminal screws.
- (29) Refit the rubber sleeve, and the dust excluders to the inlet and outlet connections.

AUF 201 type pump

This type of pump is fitted to later vehicles. The instructions given for the SP pump apply, with the exception of items (4), (6), and (18); for item (4) substitute instructions (30) and (31).

- (30) Unscrew the two screws securing the spring clamp plate which holds the inlet and outlet nozzles. Remove the nozzles, filter and valve assemblies, being careful to note their correct positions for replacement.

Rocker finger settings (AUF 201)

- (31) After reassembly the spring blade of the contacts should rest against the ridge of the pedestal mounting when the outer rocker is pressed onto the coil housing and a gap of .030 in. (.76 mm.) should exist between the points. When the outer

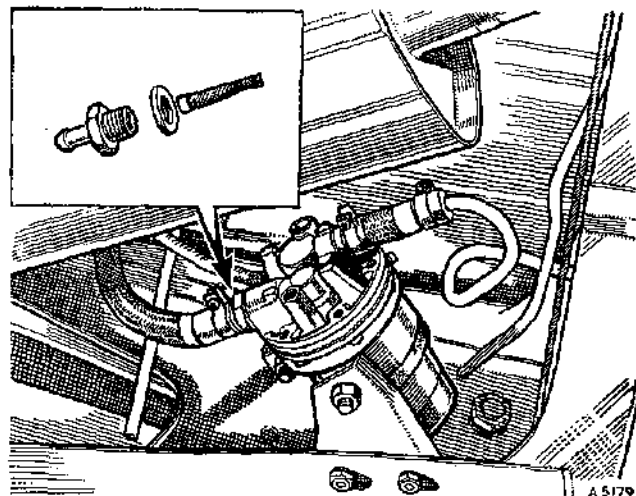
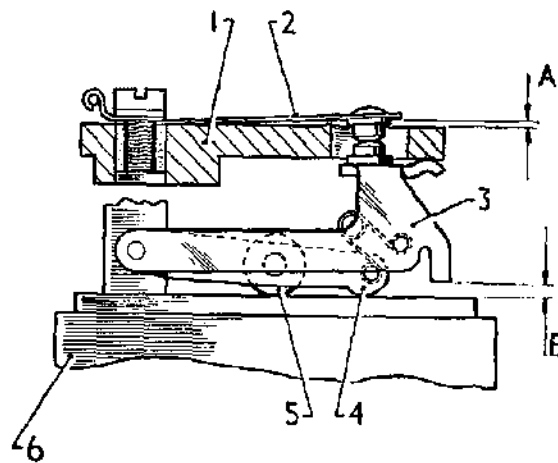

Fig. D.4
The SP-type fuel pump



A9300

Fig. D.5
The rocker finger settings

- A. .035 in. ± .005 in. (.89 mm. ± .12 mm.).
- B. .070 in. ± .005 in. (1.78 mm. ± .12 mm.).
- 1. Pedestal.
- 2. Contact blade.
- 3. Outer rocker.
- 4. Inner rocker.
- 5. Trunnion.
- 6. Coil housing.

rocker is released the spring blade should be deflected away from the ridge. If necessary, set the blade and/or rocker fingers to achieve this position.

Section D.5

FUEL PUMP TESTING

- (1) Fit the SP adaptor set to a test rig, and a cut-away cap to the pump. Connect the pump to a 12-volt battery with a voltmeter and resistance in circuit.

Priming

- (2) The pump should prime from dry in 10 to 15 seconds and the paraffin (kerosene) should rise in the glass container until it runs from the overflow drain pipe. If the level does not rise above the small hole in the drain pipe, the pump is faulty. Initial air bubbles should cease after a minute or two; if they do not, there is an air leak on the suction side.

Valves

- (3) Run the pump for about 10 minutes and turn off the fuel tap. If the pump beats within 12 seconds, the inlet valve is not seating correctly.

Minimum delivery

- (4) Partly open the fuel tap and gradually depress the spring blade to reduce the stroke. The pump should continue working with increasing frequency until it stops owing to the lack of a gap between the points.

Reduced voltage

- (5) The pump should work satisfactorily at a minimum of 9.5 volts.

THE FUEL SYSTEM

THE CARBURETTOR COMPONENTS

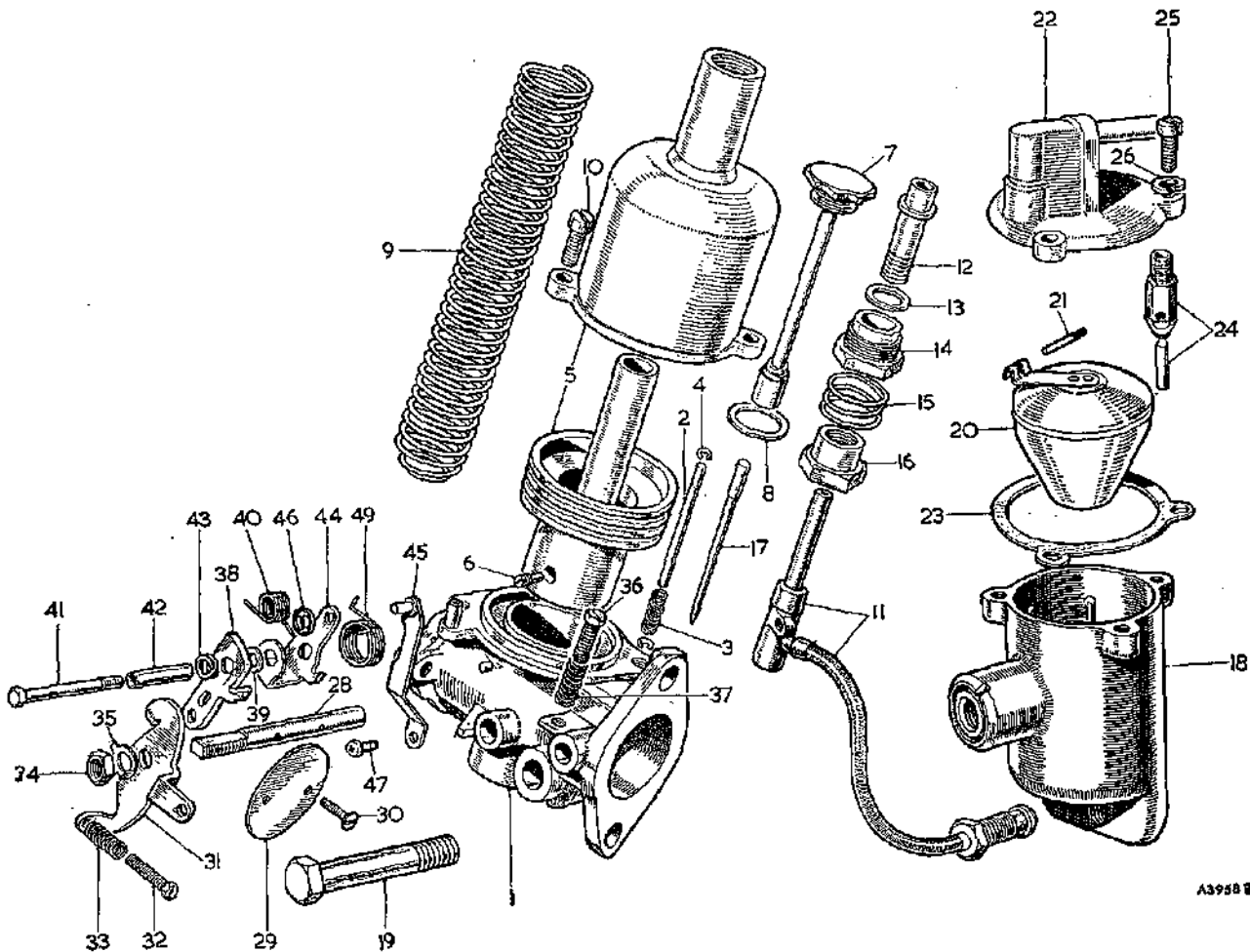

A3928 E

| No. | Description | No. | Description | No. | Description |
|-----|--------------------------------------|-----|----------------------------------|-----|---------------------------|
| 1. | Body. | 17. | Jet needle. | 34. | Throttle spindle nut. |
| 2. | Piston lifting pin. | 18. | Float-chamber body. | 35. | Tab washer for nut. |
| 3. | Spring for pin. | 19. | Float-chamber securing bolt. | 36. | Idling stop screw. |
| 4. | Circlip for pin. | 20. | Float and lever assembly. | 37. | Spring for stop screw. |
| 5. | Suction chamber and piston assembly. | 21. | Lever hinge pin. | 38. | Cam lever. |
| 6. | Needle locking screw. | 22. | Float-chamber lid assembly. | 39. | Washer. |
| 7. | Piston damper assembly. | 23. | Washer for lid. | 40. | Cam lever spring. |
| 8. | Washer for damper cap (fibre). | 24. | Needle and seat assembly. | 41. | Cam lever pivot bolt. |
| 9. | Piston spring. | 25. | Screw—float-chamber lid to body. | 42. | Pivot bolt tube. |
| 10. | Screw—suction chamber to body. | 26. | Spring washer. | 43. | Spring washer. |
| 11. | Jet assembly. | 28. | Throttle spindle. | 44. | Pick-up lever assembly. |
| 12. | Jet bearing. | 29. | Throttle disc. | 45. | Jet link. |
| 13. | Washer for jet bearing (brass). | 30. | Screw—throttle disc. | 46. | Jet link retaining clip. |
| 14. | Lock screw for jet bearing. | 31. | Throttle lever. | 47. | Jet link securing screw. |
| 15. | Lock spring. | 32. | Cam stop screw. | 49. | Spring for pick-up lever. |
| 16. | Jet adjusting screw. | 33. | Spring for stop screw. | | |

Section D.6

CARBURETTERS



IMPORTANT.—The instructions given in this section for adjusting, dismantling and reassembling the carburetters applies only to cars not fitted with exhaust emission control equipment. Carburetters fitted to cars with exhaust emission control equipment must be tuned and serviced in accordance with the instructions given in Workshop Manual Supplement AKD 4957 A.

Dismantling

- (1) Unscrew the plug and withdraw the piston damper.
- (2) Take out the two suction chamber securing screws, lift off the suction chamber and withdraw the piston and jet needle.
- (3) Disconnect the rod from the bottom of the jet, and the nylon feed tube from the base of the float-chamber; pull out the jet and tube.
- (4) Unscrew and remove the jet adjusting nut and the spring.
- (5) Unscrew the jet bearing locking nut.
- (6) Remove the float-chamber securing bolt and the float-chamber.
- (7) Take out three screws and lift off the top of the float chamber; withdraw the float.
- (8) Screw out the needle valve assembly.

Inspecting

- (9) Note the condition of the needle valve and seating; fit a new needle and seating if necessary.
- (10) If the jet needle is bent or otherwise damaged, withdraw the locking screw in the piston and fit a new needle. Push the needle in until the shoulder is flush with the lower face of the piston.
- (11) Clean and dry the piston assembly; lubricate the piston rod only with thin oil.

Reassembling

Reverse the dismantling instructions and centre the jet.

Jet centring

- (12) Screw the jet adjusting nut up as far as possible, lift the piston with the lifting pin and allow it to drop; it should drop freely onto the bridge with a soft metallic click. Repeat with the adjusting nut screwed fully down. If the piston does not fall freely in either of the tests, proceed as follows.
- (13) Carry out instructions (3) and (4) above.
- (14) Refit the adjusting nut without the spring and screw it up as far as possible.
- (15) Slacken the jet bearing lock nut until the bearing can be turned with the fingers.
- (16) Remove the piston damper and press the piston down onto the bridge. Tighten the lock nut.

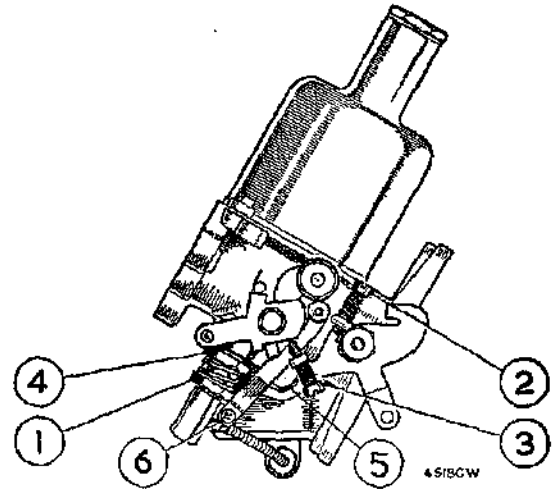

Fig. D.6
The carburetter adjusting screws

- | | |
|--------------------------------|-----------------------------|
| 1. Jet adjusting nut. | 4. Jet locking nut. |
| 2. Throttle adjusting screw. | 5. Float-chamber bolt. |
| 3. Fast-idle adjustment screw. | 6. Jet link securing screw. |
- (17) Lift the piston and note whether it falls freely; fully lower the adjusting nut and check again. If the second check produces a sharper click than the first, repeat the centring.
 - (18) Refit the parts that have been removed, pour thin oil into the hollow rod of the piston damper: to within .5 in. (12.7 mm.) of the top of the rod.

Adjustments

Slow running

- (19) Turn the throttle adjusting screw as necessary.

Mixture

- (20) Run the engine until it is at its normal temperature.
- (21) Disconnect the choke cable.
- (22) Unscrew the throttle adjusting screw until the throttle is fully closed and then screw it up about one turn.
- (23) Hold the jet up against the adjusting nut and then turn the nut until the engine runs smoothly without missing or hunting.
- (24) Raise the piston about $\frac{1}{16}$ in. (1 mm.). If there is a momentary increase in speed the adjustment is correct; if the engine stops the mixture is too weak; and if it continues to increase even when the piston is raised $\frac{1}{4}$ in. (7 mm.) the mixture is too rich.
- (25) Adjust the idling speed as required.
- (26) Set the fast idling screw so that there is a clearance of about $\frac{1}{16}$ in. (.4 mm.) between the cam and the end of the screw when the engine is warm and idling with closed throttle. Alteration may be needed after the mixture has been adjusted. Reconnect the choke cable.

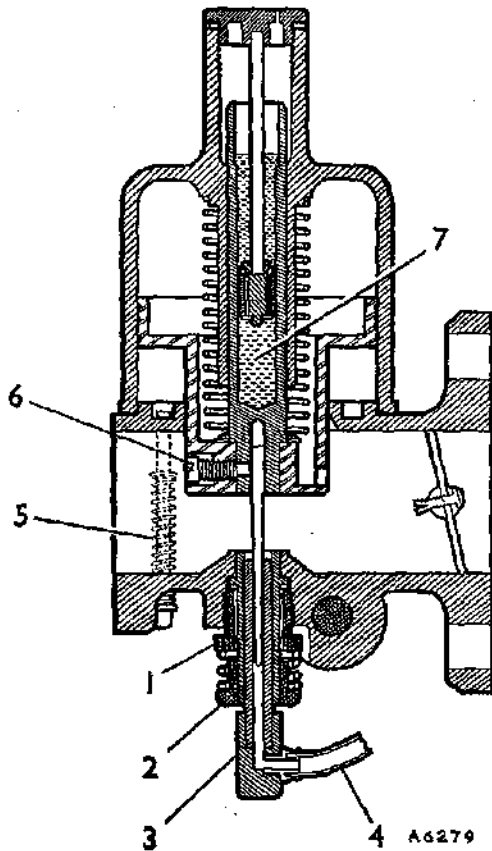

Fig. D.7

A section through the carburettor showing:

- | | |
|-----------------------|----------------------------|
| 1. Jet locking nut. | 5. Piston lifting pin. |
| 2. Jet adjusting nut. | 6. Needle securing screw. |
| 3. Jet head. | 7. Piston damper oil well. |
| 4. Nylon fuel pipe. | |

(27) Fuel starvation or flooding may be caused by an incorrect float level. To check the level, insert a $\frac{1}{8}$ in. (3 mm.) bar between the lip of the float-chamber and the hinged lever. Adjust by bending the lever where the curved portion meets the shank. On carburettors fitted with a nylon float use a test bar of $\frac{1}{4}$ in. (3.18 mm.) diameter.

Flooding

This may be caused by an incorrect float level or by a faulty needle valve.

- (28) Remove, clean, and inspect the needle valve and seating; fit a new assembly if necessary.
- (29) Check the float level.

COOPER

Slow-running

- (30) As instruction (19) but turn both screws an equal amount. Listen to the hiss at the carburettor intake and adjust the screws until the intensity of the hiss at each is the same.

Mixture

- (31) Carry out instructions (20) to (23) on each carburettor moving both nuts the same number of turns.
- (32) Raise the piston on the left-hand carburettor about $\frac{1}{8}$ in. (.8 mm.). If the engine speed increases the mixture is too rich; if the engine speed immediately decreases the mixture is too weak; if the engine speed momentarily increases very slightly the mixture is correct.
- (33) Repeat (32) on the right-hand carburettor.
- (34) Re-adjust the slow-running speed as necessary.

Linkage adjustment, Fig. D.8

- (35) Disconnect the choke cable. With the throttle shaft levers free on the shaft, put a .012 in. (.30 mm.) feeler between the shaft stop and the choke interconnecting spindle. Move each throttle lever downwards until the pin rests lightly on the lower arm of the fork in the carburettor throttle lever. Tighten the clamp of the throttle shaft lever. When both carburettors are adjusted the pins on the throttle levers should then have the correct clearance in the forks. Re-connect the choke cable and ensure that the jet heads return against the jet adjusting nuts when the choke knob is pushed fully in. Adjust the fast idling screws.

Section D.7

AIR CLEANER



Renew the filter element at the recommended periods.

Removing

- (1) Unscrew the wing nut at the top of the cleaner, remove the cover and extract the element.

Refitting

- (2) Reverse the removal procedure.

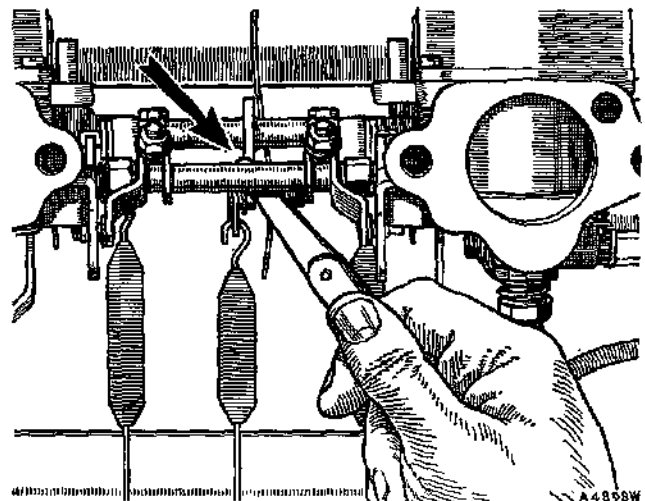

Fig. D.8

The feeler between the throttle shaft stop and the choke interconnecting spindle

COOPER

Gauze filters

Removing

- (3) Detach the breather hose and remove the four retaining screws to remove the air cleaners.

Cleaning

- (4) Wash the gauzes thoroughly in fuel, dry and re-oil with engine oil.

Refitting

- (5) Reverse the removal procedure, fitting new joint washers if necessary.

COOPER

Dry element filter

Renew the filter elements at the recommended periods.

Removing

- (6) Remove the two wing nuts and washers and remove the cover, lift out the paper elements and wipe the inside of the container to remove all dust deposit. The container may also be removed if required by careful manoeuvring over the carburettors, after releasing the throttle lever return spring and the breather hose (if fitted).

Refitting

- (7) Reverse the removal procedure, ensuring that the air manifold rubber seals are correctly positioned if the container has been removed.

Section D.8

FUEL PUMP

(Moke)

The fuel pump is located in the pannier of the left-hand side-member (Fig. D.9).

Removing

- (1) Disconnect the battery.
- (2) Remove the pannier side cover (two quick-release fasteners).
- (3) Disconnect the lead from the pump terminal.
- (4) Slacken the clips and pull the hose from the delivery pipe, and the suction hose from the pump.
- (5) Remove two nuts to release the mounting bracket.

Dismantling and assembling

- (6) Follow the instructions in Section D.4.

Refitting

- (7) Reverse the removing instructions, tighten all clips, and secure the earth lead with one of the mounting bracket nuts.

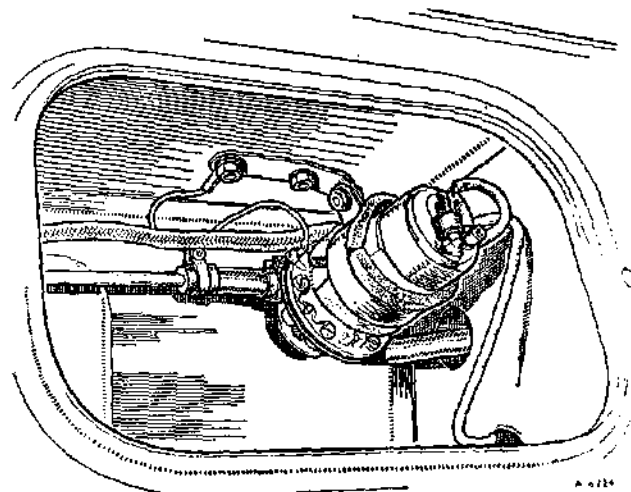

Fig. D.9

The fuel pump location in the left-hand side-member

Section D.9

FUEL TANK

(Moke)

The fuel tank is located in the left-hand side-member. Remove the tank for access to the gauge unit.

Removing

- (1) Remove the forward pannier side cover and disconnect the lead from the fuel gauge unit terminal.
- (2) Drain the fuel tank (see Fig. D.10).
- (3) Disconnect the suction hose from the fuel pump.
- (4) Remove the bottom cover-plate from the side-member.
- (5) Extract the tank-retaining screw from the top face of the side-member.
- (6) Remove the support bracket and lower the tank.

Refitting

- (7) Reverse the removal instructions.

Section D.10

TWIN FUEL TANKS

(Cooper 'S')

Removing

Both tanks

- (1) Remove the trimmed floorboard.
- (2) Disconnect the battery earth cable.
- (3) Remove the spare wheel.
- (4) Remove the fuel filler caps.
- (5) Unscrew the drain plug on the left-hand tank approximately three turns and allow the fuel to drain from both tanks.

Left-hand tank

- (6) Disconnect the electrical connections from the tank gauge unit.
- (7) Remove the tank strap securing bolt.
- (8) Disconnect the flexible fuel pipe and the vent pipe from the tank.
- (9) Base the tank to the centre of the luggage compartment and withdraw it.

Right-hand tank

- (10) Disconnect and remove the battery.
- (11) Carry out instruction (7) and disconnect the flexible hose from the left-hand tank.
- (12) Move the tank slightly from its mountings, taking care not to damage the flexible fuel pipes. The tank will still retain a small amount of fuel which should be drained off into a small container when the flexible fuel pipe is disconnected.
- (13) Disconnect the flexible fuel pipe.
- (14) Release the vent pipe from the tank and withdraw the tank from the luggage compartment.

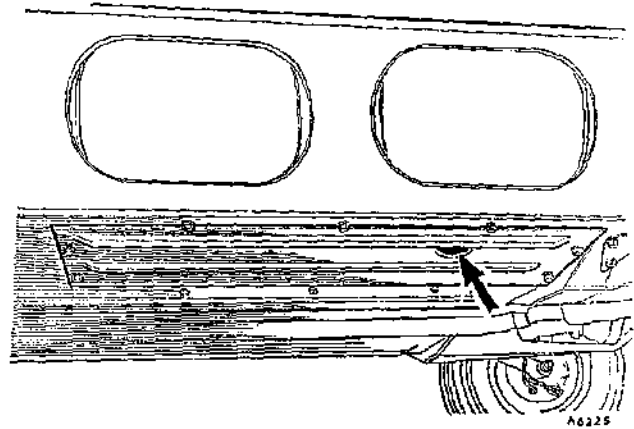

Fig. D.10

*The fuel tank drain plug access***Refitting**

- (15) Reverse the removal instructions.
- (16) Ensure that the seal around the drain plug housing is watertight.

SECTION Da

THE FUEL SYSTEM

The information in this Section refers specifically to engines fitted with automatic transmission and must be used in conjunction with Section D

| | <i>Section</i> |
|----------------------|----------------|
| †Air cleaner | Da.1 |
| †Carburetter | Da.2 |

† These operations must be followed by an exhaust emission check



Section Da.1

AIR CLEANER



Cars equipped with automatic transmission are fitted with a larger paper-element-type air cleaner.

Removing

- (1) Unscrew the wing nuts.
- (2) Disconnect the breather hose.
- (3) Lift the air cleaner from the carburetter.

Element replacement

- (4) Remove the cover from the container and lift out the paper element.
- (5) Wipe all dust deposit from inside the container.
- (6) Fit the new element and refit the cover.

Refitting

- (7) Reverse the removal procedure.

NOTE.—The air cleaner intake should be positioned adjacent to the exhaust manifold during winter operating conditions in order that the possibility of carburetter icing is reduced to the minimum. It is advisable to move the intake away from the manifold in warmer weather.

Section Da.2

CARBURETTER



(Type HS4)

Description

The HS4 carburetter is fitted to an engine equipped with automatic transmission.

The dismantling and reassembling of the carburetter is as described for the HS2 type in Section D.6.

IMPORTANT.—The instructions given in this section for adjusting, dismantling and reassembling the carburetters applies only to cars not fitted with exhaust emission control equipment. Carburetters fitted to cars with exhaust emission control equipment must be tuned and serviced in accordance with the instructions given in Workshop Manual Supplement AKD 4957 A.

Removing

- (1) Remove the air cleaner as detailed in Section Da.1.
- (2) Disconnect the mixture and throttle control cables, the suction advance pipe, and the fuel delivery hose from the carburetter.
- (3) Disconnect the governor control rod fork end from the throttle lever.

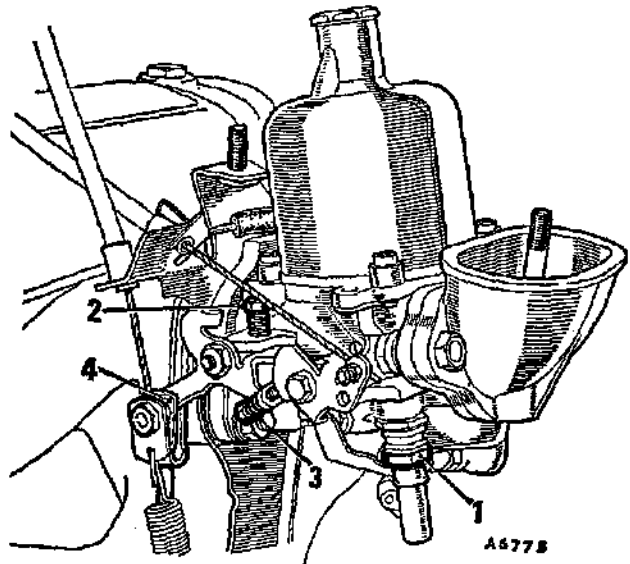

Fig. Da.1

The HS4 carburetter

- | | |
|------------------------------|-------------------------------|
| 1. Jet adjusting nut. | 3. Fast idle adjusting screw. |
| 2. Throttle adjusting screw. | 4. Governor control rod. |

- (4) Remove the securing nuts and spring washers and lift off the carburetter and the cable abutment plate.

Refitting

- (5) Reverse the removal instructions, fitting new joint washers between the manifold face and the abutment plate and carburetter flange if any have been damaged during removal.

Adjustments

The method of adjusting the jet and slow running is as described in Section D.6 with the following exceptions.

- (6) Connect a tachometer.
- (7) Select 'N' on the gear lever quadrant and apply the hand brake.
- (8) Run the engine until it attains its normal running temperature and adjust the jet as described in Section D.6.
- (9) With the carburetter correctly tuned, adjust the throttle adjusting screw (2) (Fig. Da.1) until a maximum idling speed of 650 r.p.m. is obtained.
- (10) Pull out the choke control to the maximum fast idle position. Check, and adjust if necessary, the fast idle adjustment screw (3) (Fig. Da.1), to obtain a maximum fast idle speed of 1,050 r.p.m. Push in the choke control and re-check the idling speed.
- (11) Adjust the governor control rod as detailed in Section Fa.2.

SECTION Db

THE FUEL SYSTEM

The information contained in this Section refers specifically to new or modified components fitted to the Mini range coincident with the introduction of NEGATIVE earth electrical systems and must be used in conjunction with Sections D and Da.

| | <i>Section</i> |
|---|----------------|
| Fuel pump—mechanical (type AUF 705) | Db.1 |
| Testing | Db.2 |

Section Db.1

MECHANICAL FUEL PUMP

(Type AUF 705)

General description and operation

The pump is mounted on the rear left-hand side of the crankcase and is driven from the camshaft. The cam lobe actuates the rocker lever which moves the diaphragm downwards. Fuel is drawn in through the filter, down past the inlet valve flap, and into the diaphragm chamber. When the cam lobe passes the rocker lever the diaphragm moves upwards under the influence of the spring and forces fuel through the outlet valve.

When the float needle valve closes, the diaphragm stays in the down position and the rocker arm idles until the pressure drops.

Maintenance

Filter cleaning

- (1) Clean the outside of the pump and mark the cover and body for alignment when refitting (see Fig. Db.1 for correct positions of the inlet and outlet connections).
- (2) Remove the outlet cover, sealing washer, and filter.
- (3) Clean any sediment from the filter chamber and clean the filter (air jet or fuel).
- (4) Fit a new joint washer (if necessary), refit the outlet cover and tighten the screws evenly.

Fault diagnosis

- (5) To check the fuel flow, disconnect the fuel hose at the carburettor and put the end into a container. Disconnect the (-) connection from the ignition coil and turn the crankshaft by operating the starter.
 - (a) Flow normal—examine float needle valve and seating.
 - (b) Flow normal, but falls off rapidly—check fuel tank venting. Other causes: choked pump or tank filter.
 - (c) Air bubbles emerge—air leak on suction side.
 - (d) No flow—dismantle pump, examine valves and diaphragm.

DO NOT PASS COMPRESSED AIR THROUGH THE PUMP.

Removing

- (6) Disconnect the battery and remove the air cleaner for access.
- (7) Disconnect and remove the fuel pump to carburettor feed pipe. Disconnect the fuel pump feed pipe.
- (8) Remove the pump securing nuts and partially pull the pump from the engine. Use a screwdriver and separate the insulating block from the pump; pull out the pump followed by the insulating block.

The total thickness of the insulating block with its two joint washers must not be altered.

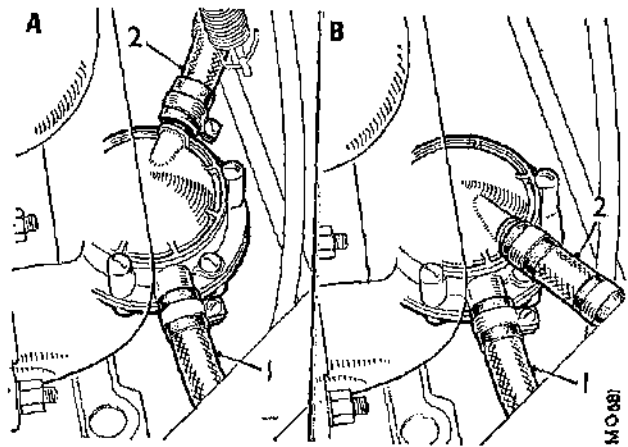

Fig. Db.1

The fuel pump location

- | | |
|----------------------|--------------------------|
| A. 1275 GT. | B. 850/1000 and Clubman. |
| 1. Inlet connection. | 2. Outlet connection. |

Dismantling

Refer to Fig. Db.2

- (9) Mark the outlet cover and the upper and lower bodies for alignment (arrowed).
- (10) Remove the outlet cover, sealing washer and filter.
- (11) Unscrew the three short securing screws and remove the upper body.
- (12) Remove the combined inlet/outlet valve.

NOTE.—The valve is a press fit; take care not to damage the fine edge of the inlet valve.
- (13) Hold the diaphragm and rocker lever against spring pressure, and tap out the rocker lever pivot pin.
- (14) Remove the rocker lever and spring.
- (15) Withdraw the diaphragm and spring, lubricate the crankcase seal to avoid damage as the spindle stirrup is pulled through.
- (16) Remove the crankcase seal and retaining cup only if the seal is to be replaced.

Replacing seal. Screw centre of service tool 18G 1119 into the retaining cup and withdraw the cup from the lower body.

Inspection

Examine components for wear and damage, particularly the diaphragm, the fine edge of the inlet/outlet valve, and the insert in the outlet cover.

Reassembling

- (17) Reverse the dismantling sequence, noting the following:
 - (a) Press the retaining cup into the lower body using 18G 1119.
 - (b) Remove any sharp edges from the diaphragm spindle and stirrup, lightly oil, position stirrup slot for engagement by the rocker lever.
 - (c) Ensure that the inlet/outlet valve groove registers in the housing, and that the fine edge of the inlet valve contacts its seating evenly.

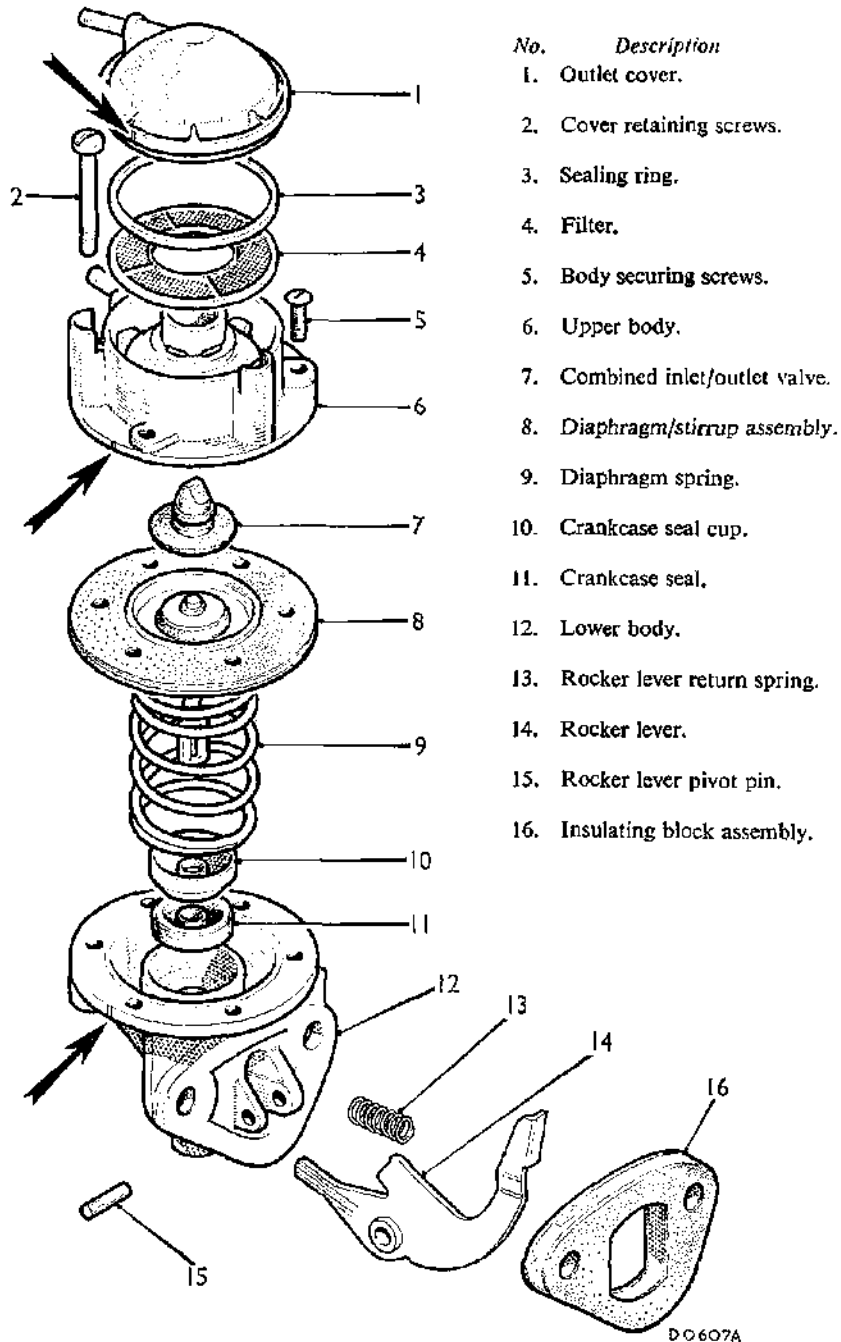

Fig. Db.2

The fuel pump components. Mark the components (arrowed) for correct reassembly

- (d) Line up the screw holes in the lower body and the holes in the diaphragm, depress the rocker lever so that the diaphragm lies flat, fit the short screws and leave slack. Fit the filter, sealing washer, and outlet cover; tighten all screws evenly.
- (e) Test pump—Section Db.2.

Refitting

- (18) Reverse the removing procedure, using new joints on the fuel pump insulating block.
- (19) Switch on the ignition and use the starter continuously for 20 seconds to prime the pump.

Section Db.2

TESTING THE FUEL PUMP

Dry test before dismantling a suspect pump and after reassembly (see Fig. Db.3).

Testing using 18G 1116

Suction

- (1) Connect the gauge to the inlet nozzle.
- (2) Operate the rocker lever, using the extension lever, through three full strokes. Minimum vacuum reading 6 in. (150 mm.) Hg, must not drop more than 2 in. (50 mm.) in 15 seconds.
- (3) Disconnect the gauge.

Delivery

- (4) Connect the gauge to the outlet nozzle.
- (5) Operate the rocker lever, using the extension lever, through two full strokes. Minimum pressure reading 3 lb./sq. in. (.2 kg./cm.²), must not drop more than ½ lb./sq. in. (.04 kg./cm.²) in 15 seconds.

Testing without gauge

A reasonable indication of pump condition can be obtained using the following procedure:

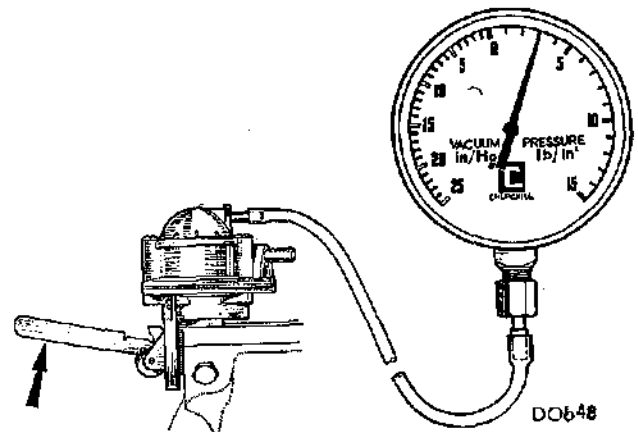
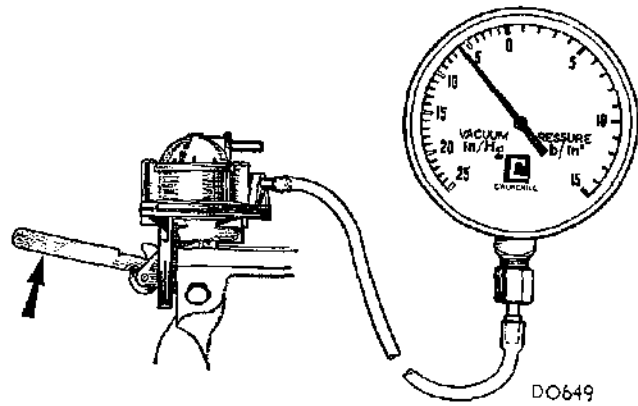

Fig. Db.3

Testing the pump for suction (above) and for pressure (below) using Service tool 18G 1116

Suction

- (1) Hold a finger over the inlet nozzle and operate rocker lever through three full strokes.
- (2) Release finger; a noise caused by suction should be heard.

Delivery

- (3) Hold a finger over the outlet nozzle and depress the rocker arm fully. Pressure should hold for up to 15 seconds.

SECTION E

THE CLUTCH

| | |
|--|-----------------------|
| Adjustments | <i>Section</i> E.2 |
| Overthrow | |
| Pedal movement | |
| Throw-out stop | |
| Drag | E.3 |
| Master cylinder | E.4 |
| Overhaul (coil pressure spring type) | E.1 |
| Removal (diaphragm spring type) | E.6 |
| Slave cylinder | E.5 |

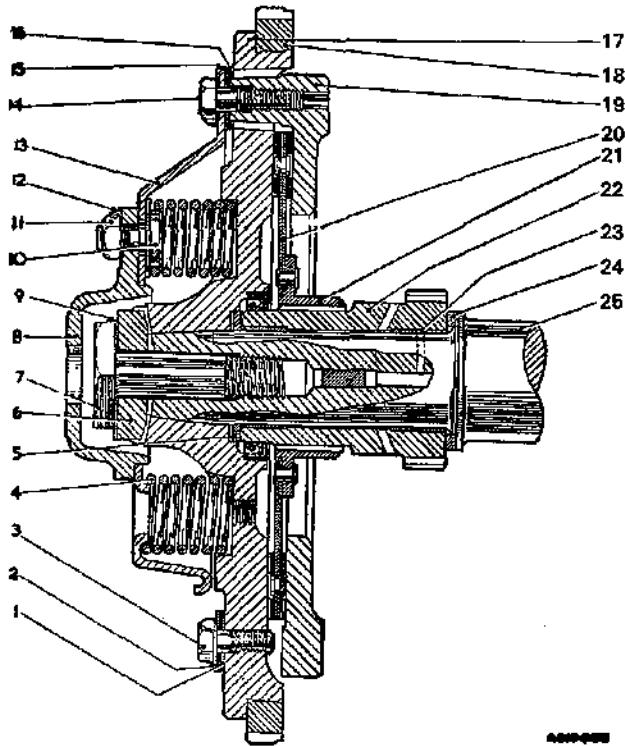

Fig. E.1

A section through the clutch assembly

- | | |
|------------------------------|------------------------------|
| 1. Driving strap. | 14. Driving pin. |
| 2. Lock washer. | 15. Lock washer. |
| 3. Driving pin. | 16. Driving strap. |
| 4. Pressure spring. | 17. Flywheel. |
| 5. Circlip. | 18. Starter ring. |
| 6. Keyed washer. | 19. Pressure plate. |
| 7. Flywheel screw. | 20. Driven plate. |
| 8. Thrust plate. | 21. Driven plate hub. |
| 9. Locking washer. | 22. Crankshaft primary gear. |
| 10. Pressure spring guides. | 23. Primary gear bearing. |
| 11. Guide nut. | 24. Thrust washer. |
| 12. Lock washer. | 25. Crankshaft. |
| 13. Pressure spring housing. | |

Section E.1

OVERHAUL (Coil Pressure Spring Type)

Removing

- (1) See Section A.11.

Dismantling

- (2) Mark the driving pins, driving straps, and the housing so that these parts can be refitted in their original positions. Note the clutch balance mark (Fig. E.2).
- (3) Insert the three screws (Service tool 18G 304 M) through the recessed holes in the pressure spring housing and screw them into the flywheel.
- (4) Screw the nuts down against the housing with the fingers and then tighten them one turn at a time until the load is off the driving pins.

- (5) Unscrew the three driving pins.
- (6) Unscrew the nuts of the Service tool 18G 304 M, gradually releasing the housing. Remove the housing and the springs.

Inspecting

- (7) Inspect the housing for elongation of the driving pin holes.
- (8) Inspect the driving pins for ridging and wear; fit three new pins if any are worn.
- (9) Inspect the driving straps; fit three new ones if any are worn.

Reassembling

NOTE.—When reassembling, fit the pressure plate to the clutch cover with the marks 'A' adjacent to each other and fit the clutch unit to the flywheel as shown in Fig. E.2.

- (10) Centralize the driven plate and the flywheel hub with Service tool 18G 571.
- (11) Locate the springs, housing and driving straps, and tighten the nuts evenly (Service tool 18G 304 M)
- (12) Insert and tighten the driving pins. If the driving straps have been removed from the flywheel, ensure that the spacing washers are refitted between the straps and the flywheel face.

Refitting

- (13) Reverse the removing instructions (Section A.11)

Section E.2

ADJUSTMENTS

Pedal movement

- (1) Pull the operating lever outwards until all free movement is taken up, then check the clearance between the lever and the stop.

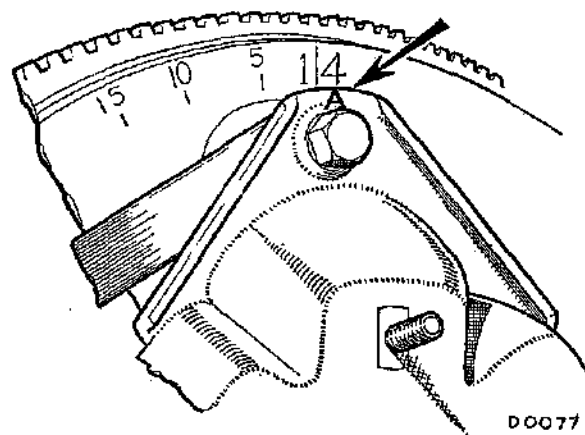

Fig. E.2

The fitted position of the clutch cover, with the balance mark 'A' adjacent to the 1/4 timing mark on the flywheel

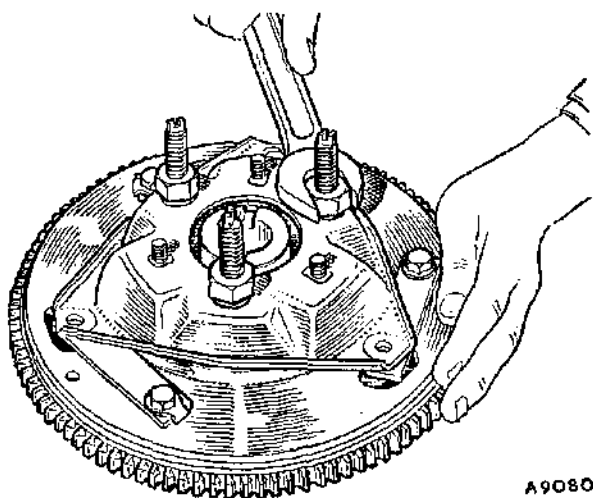

Fig. E.3

The clutch pressure springs being compressed with the aid of Service tool 18G 304 M, with Service tool 18G 571 used to keep the driven plate and flywheel hubs centralized during the operation

- (2) If necessary, adjust the stop to give a clearance of .060 in. (1.5 mm.). On later models with the throw-out stop, adjust to give a clearance of .020 in. (.50 mm.).

Throw-out stop (later models)

Adjustment is normally only necessary if the stop has been removed during overhaul.

- (3) Screw the stop and locknut away from the clutch housing to the limit of its travel.
- (4) Fully depress the pedal.
- (5) Screw the stop up against the housing, release the pedal and screw up another .007 to .010 in. (.20 to .25 mm.), approximately one flat of the locknut.
- (6) Re-check the pedal movement (items (1) and (2)).

Clutch over-throw

To test

- (7) Run the engine at its normal temperature and at about 500 r.p.m.
- (8) Depress and release the pedal three or four times; if the engine stalls or slows down appreciably, over-throw is occurring.

To rectify

- (9) Check the pedal movement and test for over-throw.
- (10) Adjust the pedal movement to a maximum of .075 in. (2.0 mm.) and test for over-throw.
- (11) Fit a stronger lever return spring and test for over-throw.
- (12) If over-throw persists, fit new pressure springs.

Section E.3

DRAG

With the car stationary, run the engine and hold the clutch out for several seconds; if drag persists, carry out the following test in sequence.

- (1) Check for air leaks in the hydraulic system.
- (2) Check the pedal movement.
- (3) Check the crankshaft end-float (Section A.25).
- (4) Dismantle the clutch and fit a new flywheel oil seal (if fitted).

Section E.4

MASTER CYLINDER

Removing

- (1) Disconnect the pedal lever from the push-rod.
- (2) Unscrew the pipe union from the cylinder.
- (3) Remove the two bolts securing the unit to the bulkhead.

Dismantling

- (4) Drain out the fluid.
- (5) Pull back the rubber dust cover.
- (6) Extract the circlip, dished washer, and push-rod.
- (7) Withdraw the piston cups and spring from the barrel.
- (8) Use only the fingers to remove the secondary cup from the piston.

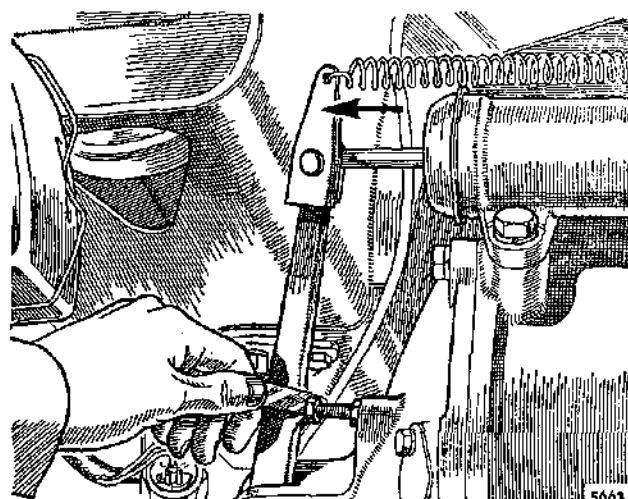

Fig. E.4

A clearance of .060 in. (1.52 mm.) or .020 in. (.50 mm.) on later models must exist between the adjustable clutch return stop and the operating lever

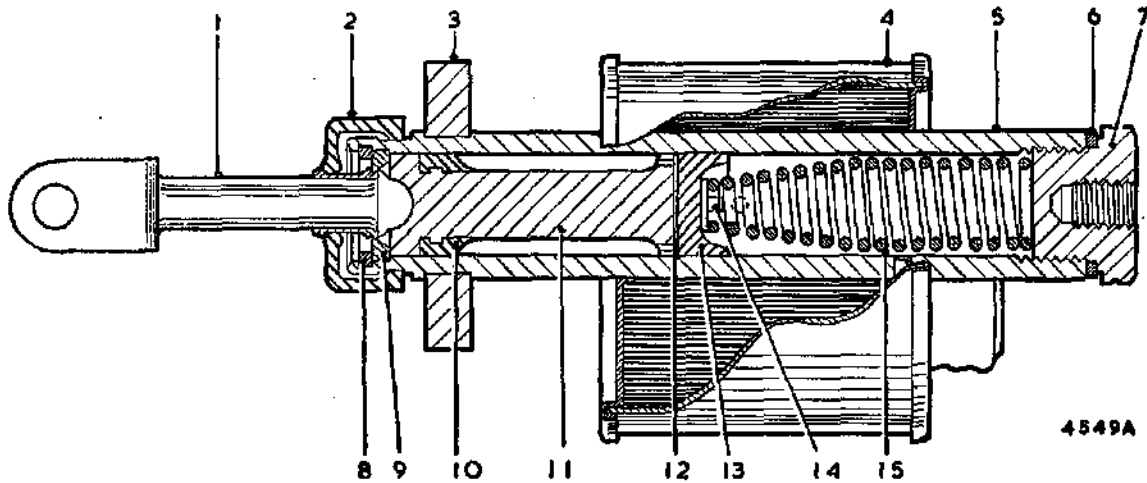

Fig. E.5

A section through the clutch master cylinder

- | | | |
|---------------------|--------------------|----------------------|
| 1. Push-rod. | 6. Washer. | 11. Piston. |
| 2. Rubber boot. | 7. End plug. | 12. Piston washer. |
| 3. Mounting flange. | 8. Circlip. | 13. Main cup. |
| 4. Supply tank. | 9. Stop washer. | 14. Spring retainer. |
| 5. Body. | 10. Secondary cup. | 15. Return spring. |

Reassembling

- (9) Clean all rubber parts with brake fluid and remove all traces of petrol (fuel), kerosene, and trichloroethylene from the metal parts.
- (10) Fit new rubbers and assemble the internal components lubricated with brake fluid.
- (11) Stretch the secondary cup over the end flange of the piston with the lip of the cup towards the opposite end of the piston; work it round to ensure correct sealing.
- (12) Insert the return spring, largest coils first. Make sure the spring seat is positioned on the small end of the spring.
- (13) Insert the main cup, lip first, and press it down onto the spring seat.
- (14) Push the piston down the bore and refit the push-rod, circlip, and rubber dust cover.

Refitting

- (15) Reverse the removing instructions and fill up with Lockheed Super Heavy Duty Brake Fluid, or (COOPER), Lockheed Disc Brake Fluid. Bleed the system.

- (3) Disconnect the push-rod from the clutch lever.

- (4) Unscrew the two securing bolts and remove the cylinder from the housing.

Dismantling

- (5) Clean the exterior before stripping.
- (6) Withdraw the rubber boot and push-rod.
- (7) Remove the circlip, piston, piston cup, cup filler, and return spring.
- (8) Renew all rubber parts: examine the remainder and renew as required.

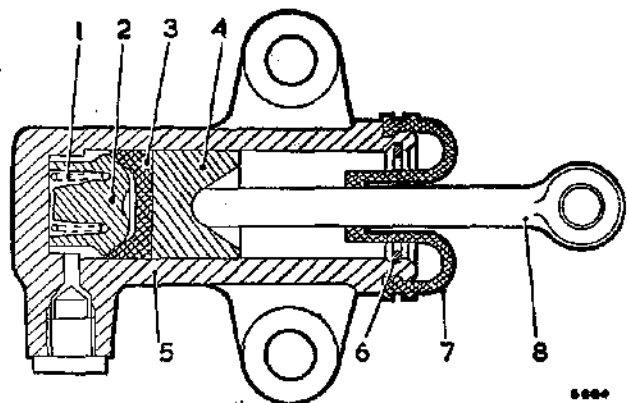

Fig. E.6

A section through a clutch slave cylinder

- | | |
|----------------|-----------------|
| 1. Spring. | 5. Body. |
| 2. Cup filler. | 6. Circlip. |
| 3. Cup. | 7. Rubber boot. |
| 4. Piston. | 8. Push-rod. |

Section E.5

SLAVE CYLINDER

Removing

- (1) Attach a bleed tube to the cylinder bleed nipple and a container, pump the pedal and drain out the fluid.
- (2) Disconnect the pressure pipe.

Reassembling

Carry out items (5) to (8) in the reverse order.

Refitting

Reverse the removal procedure items (1) to (4) and bleed the system.

Section E.6

**CLUTCH
(Diaphragm Spring Type)**

A diaphragm spring replaces the six conventional coil pressure springs on this clutch assembly.

Remove and refit the flywheel and clutch as detailed in Section A.28.

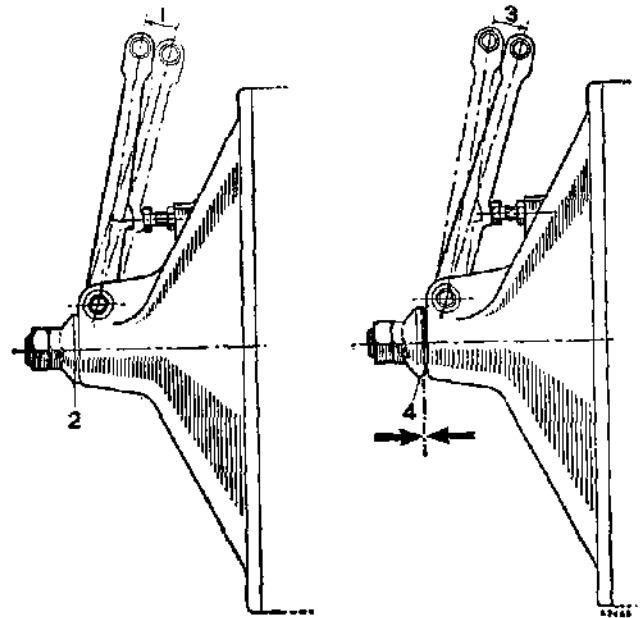

Fig. E.7

(1) The clutch fully released, with (2) the throw-out stop screwed up to the cover boss. (3) The clutch fully engaged and the stop (4) screwed up a further $\cdot007$ to $\cdot010$ in. ($\cdot178$ to $\cdot254$ mm.) towards the cover boss



SECTION F

THE TRANSMISSION

| | <i>Section</i> |
|---|----------------|
| Differential assembly | F.4 |
| Synchronizing cones | F.5 |
| Third motion shaft | |
| Three-speed synchromesh transmission | F.2 |
| Four-speed synchromesh transmission | F.3 |
| Transmission—dismantling and reassembling | F.1 |

NOTE

The gear change remote control shaft lubrication nipple on the differential cover requires attention at major overhaul periods only, when grease should be used.

Section F.1

TRANSMISSION

Dismantling

- (1) Remove the transmission casing from the crankcase (Section A.19).
- (2) Withdraw the idler gear with its thrust washers.
- (3) Remove the differential assembly (Section F.4).
- (4) Withdraw the reverse detent plug, plunger, and spring or the reverse light switch and plunger, where fitted.
- (5) Remove the clamp and key from the inner end of the gear change operating shaft and pull out the shaft.
- (6) Remove the speedometer pinion bush securing screw and withdraw the bush assembly and pinion.
- (7) Remove the speedometer gear retaining plate and the gear.
- (8) Remove the securing nuts and screws, and pull off the front cover.
- (9) Remove the selector interlocking arm.
- (10) Disconnect the oil suction pipe from the bracket (where a clip is fitted), and the flange and withdraw the pipe from the strainer.
- (11) Extract the circlip and withdraw the first motion shaft roller bearing using Service tool 18G 705 and adaptor 18G 705 C.
- (12) Use the selector shafts and lock first and third gears together.
- (13) Tap back the locking washers and remove the first motion shaft nut. Use Service tool 18G 587 to remove the final drive gear nut, and withdraw both the input and final drive gears.
- (14) Tap back the locking plates, remove the four securing screws and the third motion shaft bearing retainer and packing shims.
- (15) Remove the layshaft and reverse shaft locking plate, push the layshaft from the clutch side of the casing and remove the laygear and thrust washers.
- (16) Unscrew the plugs from the outside of the casing and withdraw the selector rod interlocking plungers and springs.
- (17) Remove the first motion shaft bearing circlip and withdraw the bearing and shaft from the casing with Service tools 18G 284 and 18G 284 B.

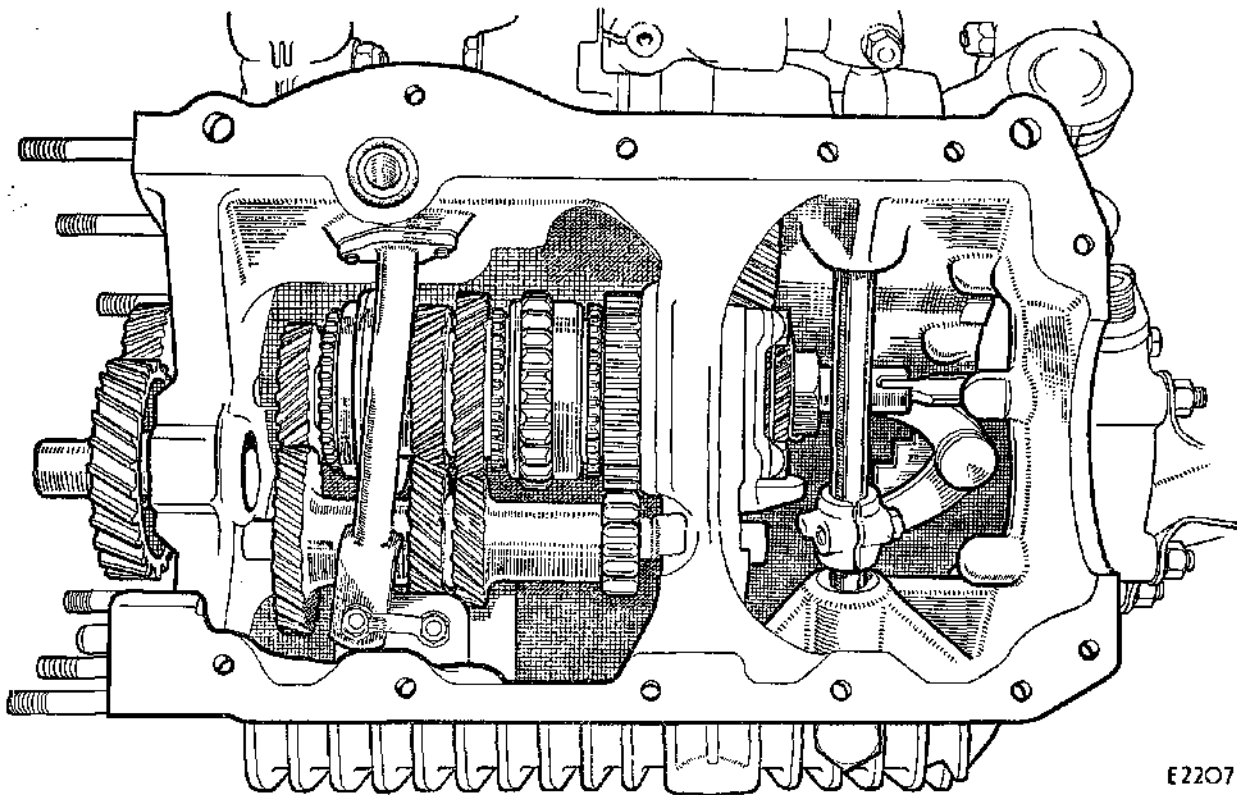

Fig. F.1

The four-speed synchromesh transmission assembly, with all the gears assembled into the casing

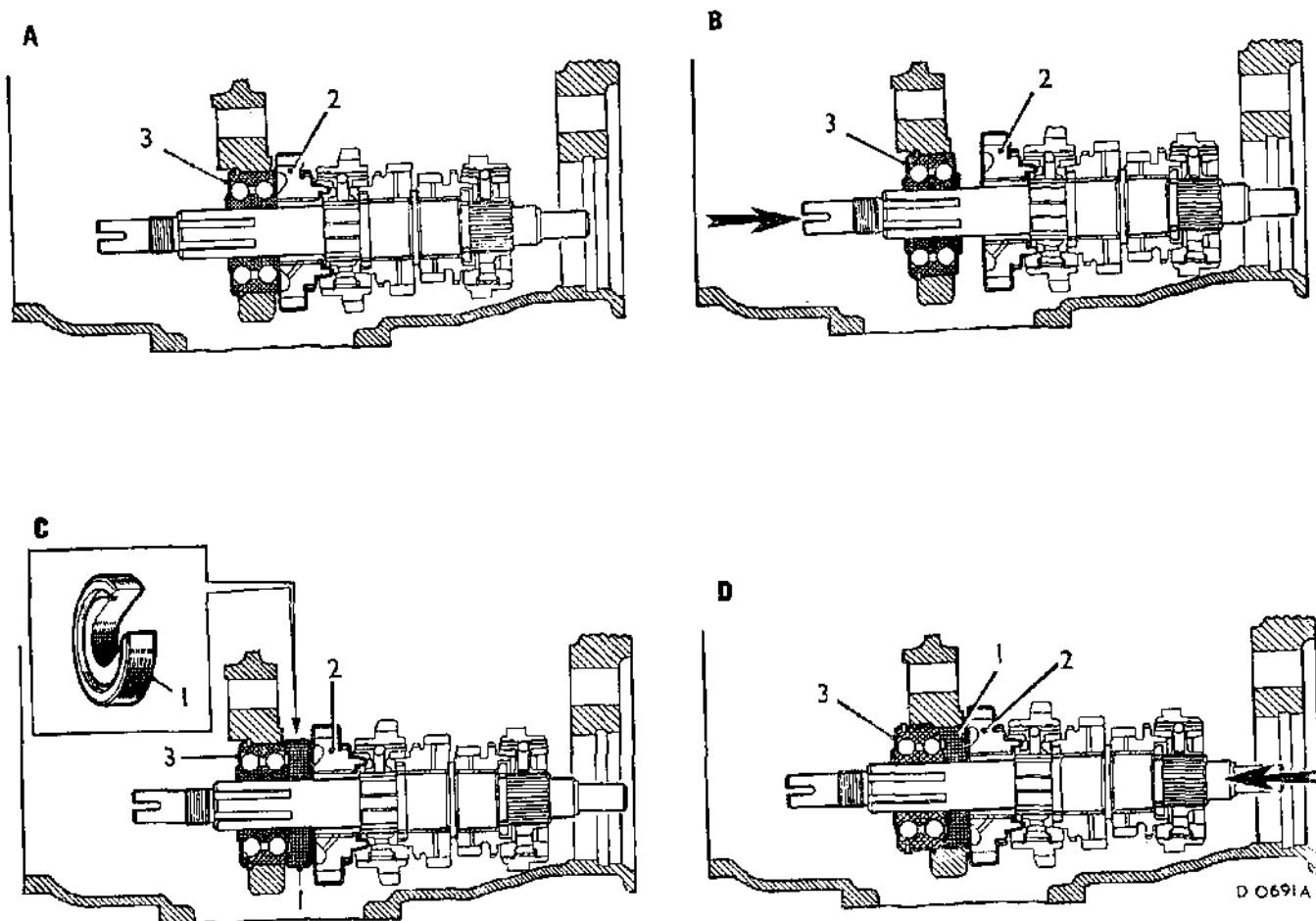

Fig. F.2
Removing the third motion shaft bearing

(18) Refer to Fig. F.2. Drift the third motion shaft backwards, as indicated by the arrow in (B), until a special Service tool (1) can be placed between the first speed gear (2) and the bearing (3), as illustrated in (C). On three-speed synchromesh gearboxes use 18G 613, and on four-speed units 18G 1127 with their relieved side towards the bearing. These two tools must not be interchanged, or the bearing or casing will be damaged. Drift the third motion shaft forward as illustrated in (D), to push the bearing (3) from the web, taking care not to damage the selector forks. Pull the bearing from the shaft, and lift the shaft from the casing.

(19) Remove the strainer assembly.

(20) Withdraw the reverse shaft, gear and selector fork.

The following operations are only necessary if complete stripping of the casing is required.

(21) Unscrew the selector shaft/fork locking screws and withdraw the shafts and forks.

(22) Remove the circlip from the reverse gear shifter lever pivot pin and remove the lever.

Reassembling

(23) If the gearbox has been completely stripped, first refit the reverse gear shifter lever and pivot pin. Push in the selector rods from the front of the casing, engage them with the selector forks, tighten the selector screws, and secure the lock nuts.

(24) Position the reverse gear and fork, and refit the reverse shaft, with the plain end foremost.

(25) Refit the oil strainer and smear some grease onto the sealing ring to assist when fitting the oil suction pipe.

(26) Refer to item (18). Refit the third motion shaft assembly with the slotted end passing through the centre web of the casing. Engage the sliding hubs with the selector forks.

(27) Refer to item (17). Drift the first motion shaft and bearing assembly into the casing using Service tool 18G 579 (modified).

Use Service tool 18G 569 to gauge the correct thickness of circlip required to retain the bearing assembly. Try the thicker side of the gauge first; the two sizes are marked on the handle. Refer to

Fig. F.3, which illustrates this operation, and fit the circlip selected from the chart beneath it.

- (28) Refer to item (18). Drift the third motion shaft bearing into the central web using Service tool 18G 579 modified, together with the spacer washer.
- (29) Refit the laygear with the standard sized thrust washer at one end, and measure the gap at the other. Refer to the chart (Fig. F.4) to select the correct variable thrust washer, to give an end clearance of between .002 and .006 in. (.05 and .15 mm.). On three-speed synchromesh gearboxes the small thrust washer is of a standard size, the large one selective, and vice versa on four-speed synchromesh gearboxes.

Use the dummy layshaft, Service tool 18G 471 to position the thrust washer, and refit the layshaft from the clutch side, with its slotted end positioned horizontally and towards that of the reverse shaft. Refit the layshaft and reverse shaft locking plate.

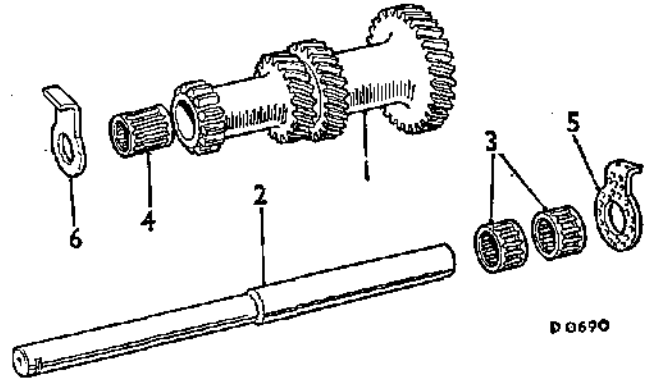

Fig. F.4

The laygear assembly. With the standard-sized thrust washer fitted, use the table below to select the correct size of variable washer. The part numbers of the thrust washers available for the three-speed and four-speed synchromesh gearboxes are given in columns 'A' and 'B' respectively

1. Laygear.
2. Layshaft (un-stepped on three-speed synchromesh units).
3. Needle-roller bearings (one only on three-speed synchromesh units).
4. Needle-roller bearing.
5. Large thrust washer.
6. Small thrust washer.

Early three-speed synchromesh gearboxes were fitted with uncaged needle-roller bearings, with which the later caged type are interchangeable.

| When gap is | A | B |
|--|---------|---------|
| .125 to .127 in. (3.18 to 3.22 mm.) | 88G 325 | 22G 856 |
| .128 to .130 in. (3.25 to 3.30 mm.) | 88G 326 | 22G 857 |
| .131 to .133 in. (3.32 to 3.37 mm.) | 88G 327 | 22G 858 |
| .134 in. (3.41 mm.) | 88G 328 | 22G 859 |

- (30) Refit the third motion shaft bearing retainer without any shims, lightly tighten the bolts and measure the gap, see Fig. F.5. Fit the shims required (see chart), ensure that they are fitted under the layshaft and reverse shaft locking plate, and finally tighten the bolts and turn over the tab washers.
- (31) Refer to item (10). Insert the oil suction pipe into the oil strainer assembly, and tighten first the external flange securing bolts and then the bracket retaining bolts. Take care not to displace the oil seal from the strainer.
- (32) Fit new idler gear needle-roller bearings if required. Engage the expandable collets of Service tool 18G 581 with each old bearing and screw up the nut on the tool to extract them, after removing the outer circlip (when fitted) from the transmission casing boss.

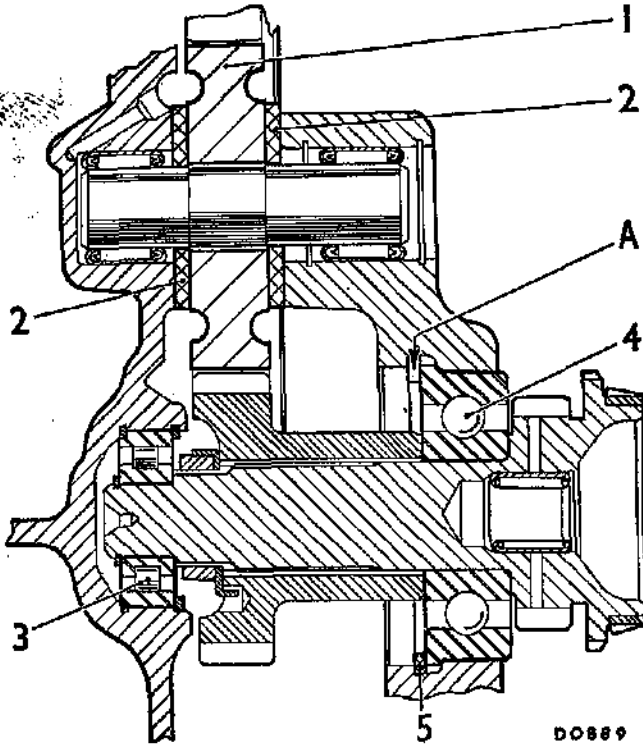

Fig. F.3

A section through the idler gear and first motion shaft. Measure the gap 'A' between the bearing face and register with Service tool 18G 569, and fit the appropriate circlip as indicated by the chart below

1. Idler gear.
2. Idler gear thrust washers.
3. First motion shaft roller bearing.
4. First motion shaft ball bearing.
5. First motion shaft circlip.

| When gap is | Use circlip Part No. |
|-------------------------------------|----------------------|
| .096 to .098 in. (2.43 to 2.48 mm.) | 2A 3710 |
| .098 to .100 in. (2.48 to 2.54 mm.) | 2A 3711 |

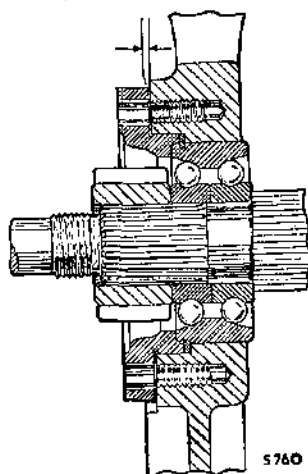

Fig. F.5

A section through the third motion shaft bearing and retainer. Use the following table to ensure that the correct thickness of shim is used

| When gap is | Use shims totalling |
|-----------------------------------|---------------------|
| .005 to .006 in. (.13 to .15 mm.) | .005 in. (.13 mm.) |
| .006 to .008 in. (.15 to .20 mm.) | .007 in. (.18 mm.) |
| .008 to .010 in. (.20 to .25 mm.) | .009 in. (.23 mm.) |
| .010 to .012 in. (.25 to .30 mm.) | .011 in. (.28 mm.) |
| .012 to .014 in. (.30 to .35 mm.) | .013 in. (.33 mm.) |
| .014 to .015 in. (.35 to .38 mm.) | .015 in. (.38 mm.) |

Use Service tool 18G 582 (three-speed synchromesh) or 18G 1126 (four-speed synchromesh) to fit the new bearings. Use the collar supplied with each tool to control the depth to which the bearing is pressed into the flywheel housing, the boss of which must be well supported during this operation. These collars are not required when fitting the transmission casing bearing, since each tool's shoulder governs the depth to which it is pressed. Replace the outer circlip, if fitted.

- (33) Refer to items (12) and (13). Refit the input and final drive gears, and, using new lock washers tighten the first motion shaft and final drive gear nuts, using Service tool 18G 587 for the latter; the torque figures are given in 'GENERAL DATA'.
- (34) Refit the first motion shaft roller bearing and circlip.
- (35) Reverse the instructions in item (16).
- (36) Refit the selector interlocking arm, the front cover, the speedometer gear and cover, pinion, bush, and pinion housing. Push in the gear change operating shaft, refit its key and clamp, and replace the reverse detent plunger and spring, or the reverse light switch (if fitted).
- (37) Refit the differential and check adjustment as given in Section F.4.

- (38) Refit the idler gear and thrust washers, with the chamfered side of each washer against the gear.
- (39) Refit the flywheel housing with a new joint washer and tighten to the torque figure given in 'GENERAL DATA'.

Check with feeler gauges that the idler gear has an end-float of between .003 and .008 in. (.08 and .2 mm.), see Fig. F.3. Thrust washers ranging in thickness from .132 to .139 in. (3.34 to 3.54 mm.) are available for adjustment.

- (40) Remove the flywheel housing and gasket, and refit the transmission unit to the engine as detailed in Section A.19, using a new housing gasket to replace the one used for the idler gear end-float check.

Section F.2

THIRD MOTION SHAFT

Three-speed synchromesh transmission

The baulk ring synchromesh is fitted to Mk. I cars from Engine No. 8AM/U/H412992 and to all Mk. II models. The dismantling and reassembling sequences for the early-type transmission are the same as detailed below except that the second and third/top gear synchronizers are not fitted with baulk rings.

Removing

- (1) Remove the third motion shaft assembly from the transmission as detailed in Section F.1.

Dismantling

- (2) Remove the first speed gear, hub and baulk ring from the rear of the shaft, and the top and third gear synchromesh hub and baulk rings from the front of the shaft.
- (3) Remove the front thrust washer by pressing down the spring-loaded locating plunger and rotating the washer until the splines register with those on the shaft. Withdraw the thrust washer and third speed gear, complete with needle-roller bearings on later type gears, and take out the plunger and spring.

Early type gears. Withdraw the third gear bush and interlocking ring, followed by the second speed gear and bush and the rear thrust washer.

Later type gears. Depress the spring loaded pegs, turn and remove the second speed gear locking collar and take out the two split washers. Pull the gear from the rear of the shaft, and remove the needle-roller bearings from their journal.

If it is necessary to separate the second or third and fourth speed striking dog from its synchromesh hub and cone assembly, press the assembly into Service tool 18G 572, to retain the three balls and springs which are located in each hub.

Reassembling*Early type gears*

- (4) Fit the rear thrust washer, then the plain half of the split bush with its flat end towards the thrust washer.
- (5) Fit the second speed gear, with the synchronizer cone facing the rear of the shaft, the interlocking ring and the splined half of the split bush. Engage the dogs of the split bushes with the slots in the interlocking ring. New bushes must be fitted, since the interference fit of the old ones will have been lost when they were removed. Heat the bushes to a temperature of 180 to 200° C. (356° to 392° F.), to allow them to be fitted without force, and to obtain a permanent 'shrink fit' on cooling.
- (6) Refit and depress the spring and locking plunger, refit the third speed gear, plain side first, and the front thrust washer. Turn the thrust washer until the plunger engages the spline and locks the washer.

Later type gears

- (7) Slide the second speed gear on from the rear of the shaft, plain side first, after sticking the needle-roller bearings to their journal with grease. Replace the two split washers, depress the two spring loaded locking pegs, and refit the locking collar, turning it until the pegs are heard to engage the splines.
- (8) From the front of the shaft refit the third speed gear, plain side first, with its needle-roller bearings. Slide on the front thrust washer and turn it until the spring loaded peg is heard to lock it.

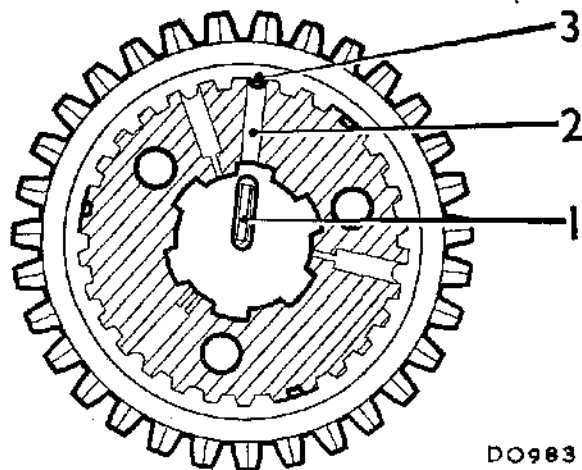

Fig. F.6

The three-speed synchronesh first and second speed gear assembly, showing the plunger (1) in its drilling in the hub (2) aligned with the cut-away tooth (3) in the gear assembly

Early and later type gears

- (9) The end-float of both the second and third speed gears when assembled on the third motion shaft must be between .0035 and .0055 in. (.09 and .13 mm.).
- (10) Refit the top and third speed synchronesh hub and baulk rings, with the plain side of the hub towards the rear of the shaft.
- (11) Refit the speed gear, hub, and baulk ring, with the cone end of the hub towards the front of the shaft.

Should the first and second speed gear assembly have been dismantled, the gear must be correctly repositioned on the hub, otherwise selection of second gear will be impossible. Ensure that the plunger in the hub aligns with the cut-away tooth in the gear assembly (see Fig. F.6), and that the cone end of the hub and the tapered side of the gear teeth are on opposite sides of the assembly.

Section F.3**THIRD MOTION SHAFT****Four-speed synchronesh transmission****Removing**

- (1) Remove the shaft assembly from the transmission as detailed in Section F.1.

Dismantling

- (2) Withdraw the top and third gear synchronesh hub and baulk rings from the front end of the shaft.
- (3) Press the front thrust washer plunger, and turn the washer until its splines register with those on the shaft, enabling it to be removed, complete with plunger and spring. Remove the third speed gear, with its caged needle-roller bearing.
- (4) Remove the first speed gear, baulk ring, and caged needle-roller bearing from the opposite end of the shaft.
- (5) Carefully lever the needle-roller bearing journal backwards sufficiently to fit Service tool 18G 2 and pull the journal from the shaft.
- (6) Remove the reverse mainshaft wheel and first/second speed synchronizer assembly, and the baulk ring.
- (7) Press in the two plungers securing the rear thrust washer, turn it to align it with the shaft splines and withdraw it from the shaft. Remove the second speed gear, and the split caged needle-roller bearing.

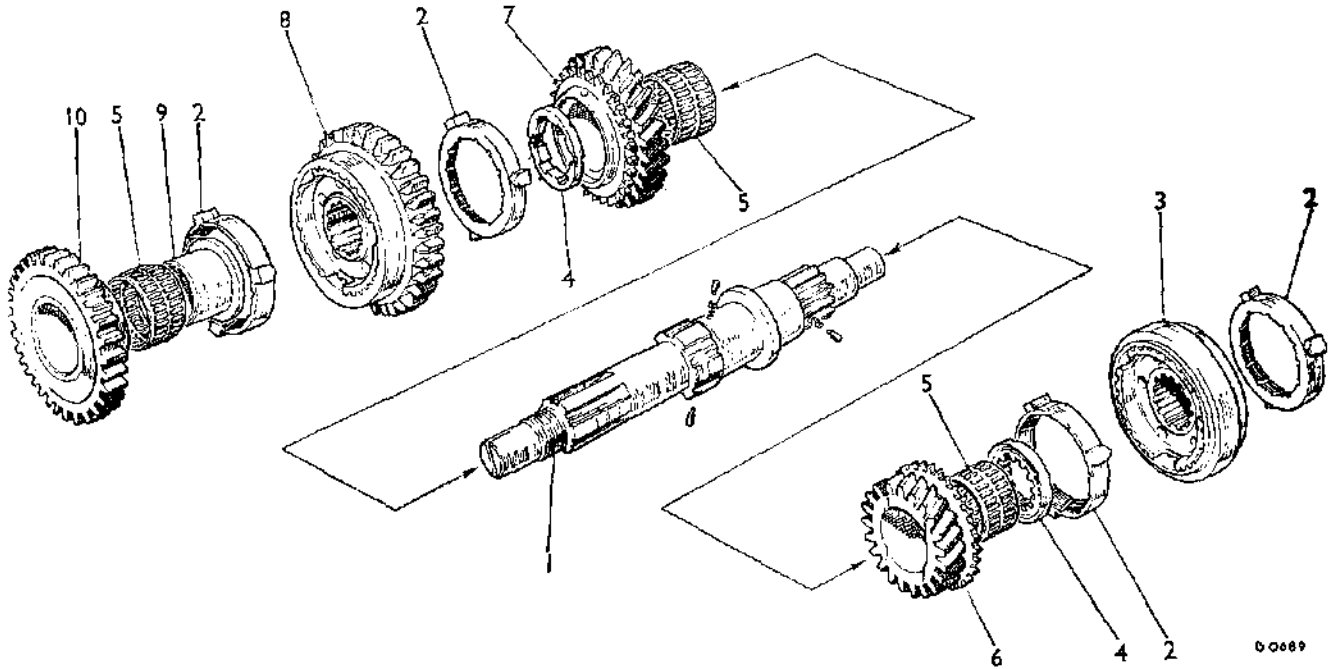

Fig. F.7

The third motion shaft assembly (four-speed synchromesh transmission)

- | | | |
|------------------------------------|----------------------------|---|
| 1. Third motion shaft | 5. Needle-roller bearings. | 8. Reverse mainshaft gear and 1st and 2nd speed synchronizer. |
| 2. Baulk rings. | 6. Third speed gear. | 9. Needle-roller bearing journal. |
| 3. 3rd and 4th speed synchronizer. | 7. Second speed gear. | 10. First speed gear. |
| 4. Thrust washers. | | |

Reassembling

- (8) Carry out the dismantling instructions, but note items (9) to (11).
- (9) Use Service tool 18G 572 to prevent the balls and springs from being lost, should it be necessary to separate the striking dogs from the synchromesh hub and cone assemblies. When reassembling the synchronizers, ensure that the long boss on both the sleeve and the hubs are on the same side.
- (10) When refitting the third and top speed synchronizer assembly, the long boss on the synchronizer sleeve must face the first motion shaft bearing. The first and second speed synchronizer assembly must be fitted with the long boss towards the first speed gear, or second speed synchromesh action will be lost.
- (11) Use Service tool 18G 186 to drift the first speed gear needle-roller bearing journal onto the third motion shaft.

Section F.4

DIFFERENTIAL ASSEMBLY

Removing

- (1) Remove the engine and transmission as detailed in Section A.13.

- (2) Remove the transmission from the engine as detailed in Section A.19 **only** if it is necessary to fit a new final drive pinion into the transmission, or if the differential components have suffered damage with the result that swarf has been introduced into the transmission unit.
- (3) Remove the gear-change extension bottom cover plate.
- (4) Release the control shaft lever from the top of the remote control shaft, which can now be withdrawn.
- (5) Extract the split pin from the slotted nuts securing both right- and left-hand driving flanges to the differential gear shafts, using Service tool 18G 669 to hold each driving flange in turn, remove the nuts and withdraw the flanges. **Do not under any circumstances use the transmission casing as a stop or leverage point when removing the driving flange nuts or other components of the transmission. Serious damage to the casing can easily result from misuse in this way.**
- (6) Unscrew the five set screws from each of the final drive end covers, and remove them from the differential housing. Note the number of shims fitted between the differential bearing and the housing.
- (7) Remove the differential housing stud nuts, withdraw the housing from the transmission case and remove the differential assembly.

THE DIFFERENTIAL COMPONENTS

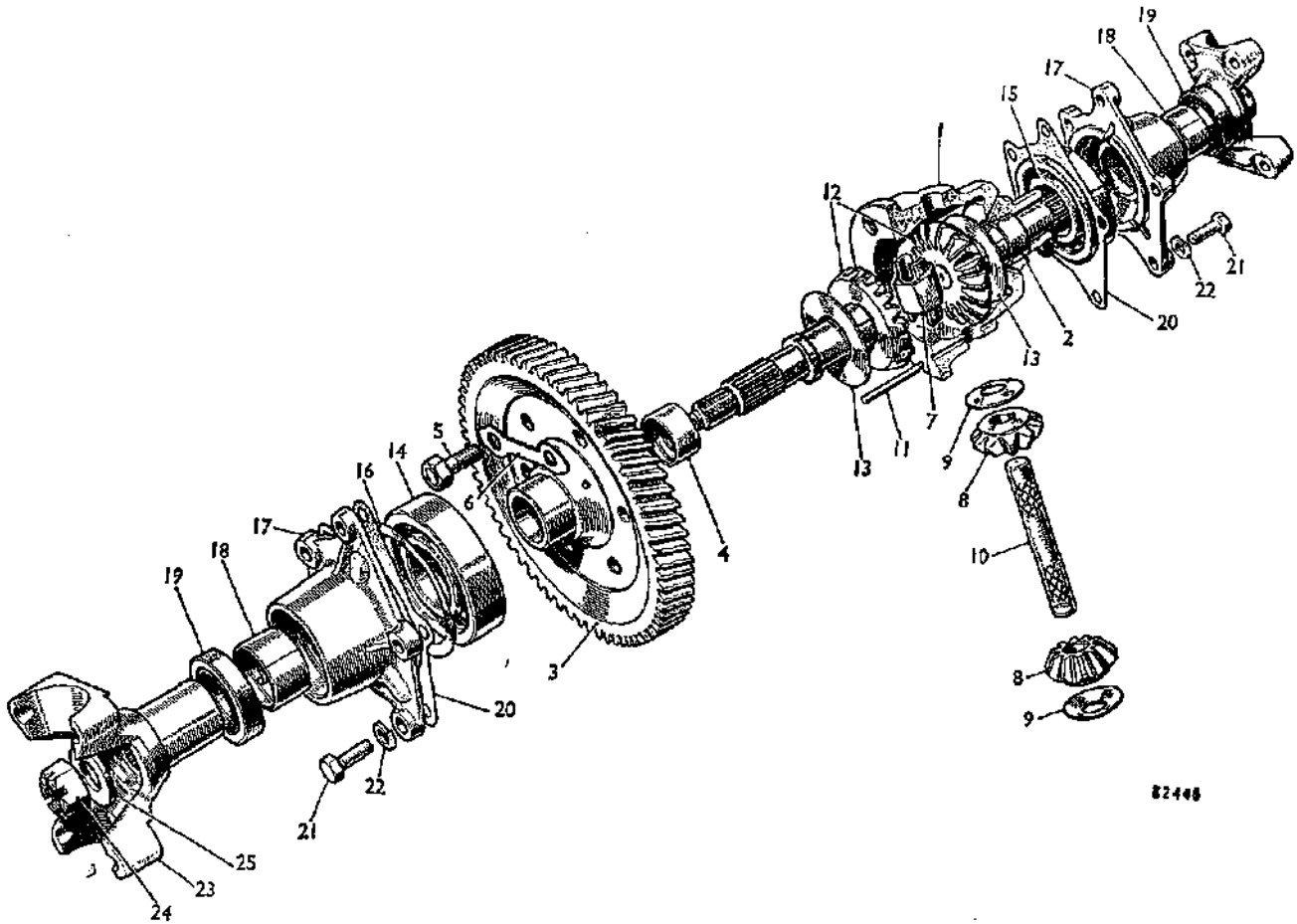

82448

| No. | Description |
|-----|-----------------------|
| 1. | Differential case. |
| 2. | Case bush. |
| 3. | Drive gear. |
| 4. | Gear bush. |
| 5. | Gear bolt. |
| 6. | Lock washer. |
| 7. | Thrust block. |
| 8. | Differential pinion. |
| 9. | Pinion thrust washer. |

| No. | Description |
|-----|---------------------|
| 10. | Centre pin. |
| 11. | Pin peg. |
| 12. | Differential gear. |
| 13. | Gear thrust washer. |
| 14. | Drive gear bearing. |
| 15. | Case bearing. |
| 16. | Bearing shim. |
| 17. | End cover. |

| No. | Description |
|-----|------------------|
| 18. | Cover bush. |
| 19. | Oil seal. |
| 20. | Cover joint. |
| 21. | End cover screw. |
| 22. | Washer. |
| 23. | Driving flange. |
| 24. | Flange nut. |
| 25. | Washer. |

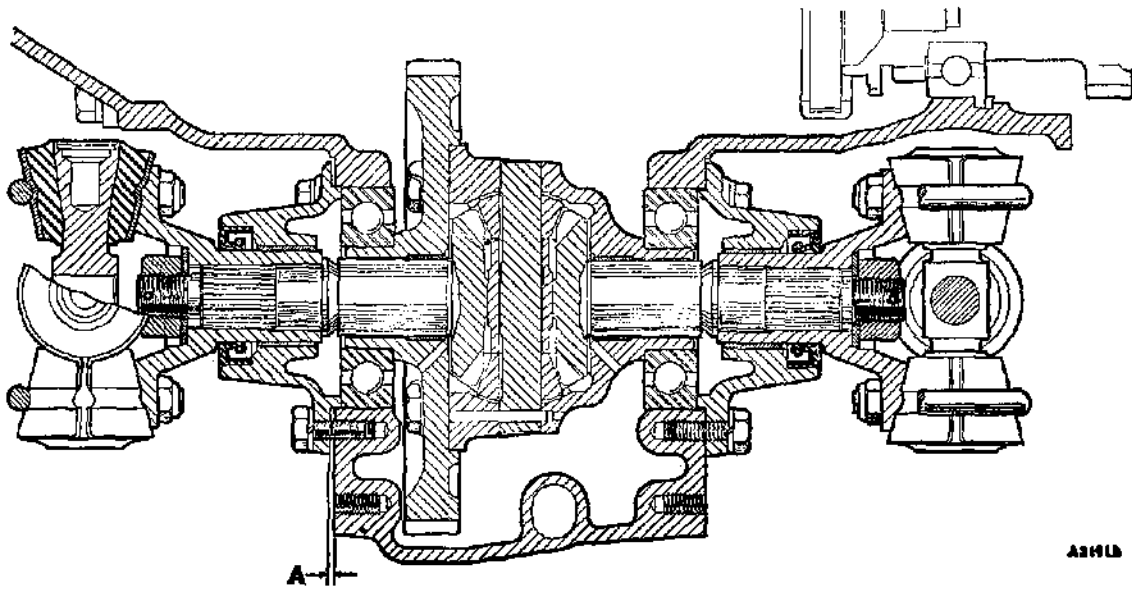

Fig. F.8

With the left-hand drive cover fitted without its joint washer, measure the gap at point 'A', and fit shims between the bearing and cover to obtain the required pre-load

Dismantling

- (8) Withdraw the two differential bearings, using Service tool 18G 2. Knock back the locking plate tabs and remove the six set bolts securing the driving gear to the cage, which may now be separated after marking them to assist in refitting them in their original positions. Extract the differential gear and thrust washer from the bore of the driving gear.
- (9) Tap out the taper pin peg to release the pinion centre pin, the thrust block, both differential pinions and thrust washers and the other differential gear and washer.

Reassembling

- (10) Reverse the dismantling sequence, making sure that the gear thrust washers are refitted with their chamfered bores against the machined face of the differential gears, and that all parts are refitted in their original positions.

Refitting

- (11) Place the differential assembly in the transmission casing with a slight bias towards the flywheel side. Refit the differential housing with its joint washers, and nip up the nuts sufficiently to hold the bearings, yet still allowing the assembly to be moved side-ways.
- (12) Refit the right-hand drive end cover together with its joint washer. Then carefully and evenly tighten

up the set screws, to displace the differential assembly away from the flywheel side and ensuring full contact between the register on the inner face of the cover and the differential bearing.

Fit the left-hand final drive cover, without its joint washer, the compressed thickness of which is .007 in. (.18 mm.). Tighten the set screws sufficiently for the cover register to nip the bearing outer race; overtightening will distort the cover flange. The required preload on the bearings is .001 to .002 in. (.025 to .05 mm.), hence the gap between the cover flange and the differential housing and transmission casing must be between .008 to .009 in. (.2 to .23 mm.). Measure this gap ('A' in Fig. F.8) with feeler gauges, and correct it as necessary by fitting shims between the bearing and the register on the cover. For example if the gap as measured is .005 in. (.13 mm.) a shim of .003 in. (.076 mm.) is required. Measure the gap in several places: any deviations will indicate that the end cover set screws have not been tightened evenly.

Remove and refit the end cover with its joint washer and the selected shims, tighten the cover screws and differential housing nuts.

NOTE.—Later assemblies are fitted with increased thrust capacity bearings, which must be fitted with the identification word 'THRUST' facing the outside, towards the end cover. Since the pre-load is increased to .004 in. (.1 mm.), adjust the gap 'A' (see Fig. F.8) with shims until it is .011 in. (.28 mm.) before the joint washer is fitted.

- (13) Refit the driving flanges, making reference to item (4). The torque tightening figure is given in 'GENERAL DATA'.

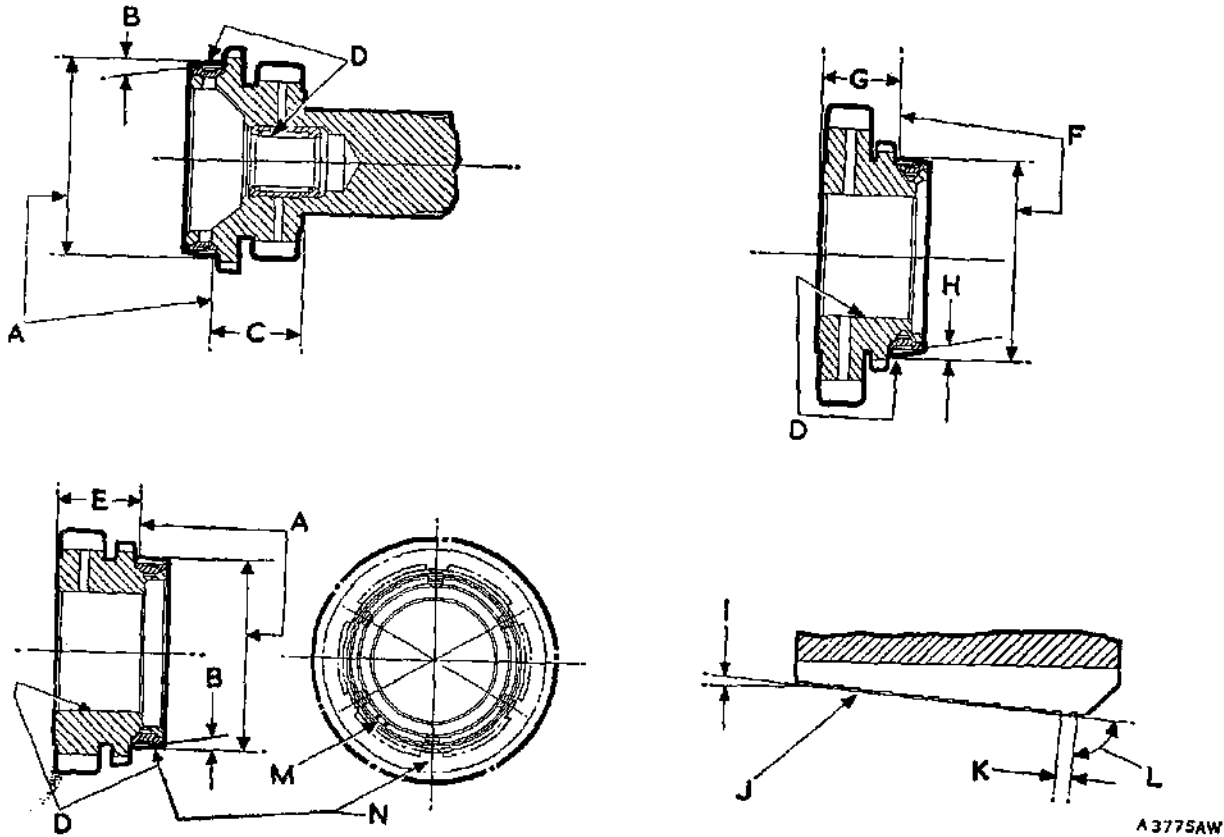

Fig. F.9

Top left: first motion shaft. Lower left: third speed mainshaft gear. Top right: second speed mainshaft gear. Lower right: Cone

Dimensions

- | | |
|---|---|
| A. Taper 2-150 in. (54-61 mm.) dia. at this line to gauge. | I. 6°. |
| B. Taper 10° 30', to be true and concentric with bore to .001 in. (.025 mm.). | J. Coarse turning may be either right or left-hand. |
| C. .909/.912 in. (23.09/23.16 mm.). | K. .015 in. (.38 mm.). |
| D. Taper to be true and concentric with bore to .001 in. (.025 mm.). | L. 90°. |
| E. .862/.865 in. (21.8/21.9 mm.). | M. One notch to be ground in position shown relative to grooves with indentations. |
| F. Taper 2-150 in. (54-61 mm.) dia. at this line to gauge. | N. Synchronizing cone to be heated in oil shrunk onto gear, and punched into holes as shown with centre-line of holes and spaces in cone in line. |
| G. .837/.840 in. (21.254/21.335 mm.). | |
| H. 8° 30'. | |

(14) Make certain that both drive shafts are equally free to rotate, otherwise the vehicle's steering may pull to one side.

(15) Refer to item (3). Position the remote control shaft lever on the ball end of the operating lever, insert the remote control shaft from underneath and engage it with the splined bore of the former. Insert the set screw after checking that the drilling in the boss and the recess in the shaft are in alignment.

(16) Reassemble the transmission, clutch assembly and housing to the engine (if removed, see item (2)).

(17) Refit the power unit into the car and reassemble the gear-change to the transmission (or refit the remote control assembly).

Section F.5

SYNCHRONIZING CONES (Non-baulk-ring Transmission)

Cones may be shrunk onto the second, third and fourth gears by heating in oil to 121° C. (250° F.) and quenching in cold water when in position.

See Fig. F.9 for machining dimension.

SECTION Fa

THE AUTOMATIC TRANSMISSION

| | <i>Section</i> |
|---|----------------|
| General description | |
| Power flow diagrams (Mechanical) | |
| Line pressure and lubrication diagrams | |
| Adjustments | Fa.2 |
| Inhibitor switch | |
| Gear-change cable and selector rod | |
| Governor control rod | |
| Pressure check | |
| Stall speed check | |
| Auxiliary pump and governor | Fa.5 |
| Differential assembly | Fa.9 |
| Fault diagnosis | Fa.1 |
| First gear free-wheel assembly (one-way clutch) | Fa.11 |
| Forward clutch | Fa.6 |
| Gear-change cable | Fa.12 |
| Gear train | Fa.7 |
| Servo assembly | Fa.8 |
| Top and reverse clutch | Fa.10 |
| Transmission unit | Fa.3 |
| Valve block | Fa.4 |

GENERAL DESCRIPTION

The automatic transmission incorporates a three-element fluid torque converter with a maximum torque conversion ratio of 2 : 1 coupled to a bevel gear train which provides four forward gears and reverse.

Engine power is transmitted from the crankshaft converter output gear through an idler gear to the input gear which drives the bevel reduction gears in the gear train assembly.

The final drive is transmitted from a drive gear to a conventional-type differential unit (similar to that fitted to a synchromesh transmission unit), which in turn transmits engine power through two flange-type coupling drive shafts employing constant velocity joints to the road wheels.

The complete gear train assembly, including the reduction gear and differential units, runs parallel to, and below, the crankshaft and is housed in the transmission casing which serves also as the engine sump.

The system is controlled by a selector lever within a gated quadrant marked with seven positions, and mounted centrally on the floor of the car. The reverse, neutral, and drive positions are for normal automatic driving, with the first, second, third, and fourth positions used for manual operation or over-ride as required. This allows the system to be used as a fully automatic four-speed transmission, from rest to maximum speed with the gears changing automatically according to throttle position and load. If a lower gear is required to obtain greater acceleration, an instant full throttle position, i.e. 'kick-down' on the accelerator, immediately produces the change.

Complete manual control of all four forward gears by use of the selector lever provides rapid changes. However, it is very important that downward changes are effected at the correct road speeds otherwise serious damage may result to the automatic transmission unit. The second, third, and top gears provide engine braking whether driving automatic or manual; in first gear a free-wheel condition exists when decelerating. Manual selection to third or second gear gives engine braking and also allows the driver to stay in a particular lower gear to suit road conditions or when descending steep hills.

The hydraulic system

Oil is drawn from the transmission casing through the main gauze strainer and pick-up pipe by the main oil pump which has a high potential output and serves both the engine lubrication and transmission systems with a common oil supply. The oil passes through drillings in the cylinder block and a pipe to the external full-flow filter and thence to the valve block.

The valve block assembly controls pressures to the transmission. Separate valves control the converter and engine pressures. The oil passes from the valve block through a long connecting pipe to the converter stator unit. Three short interconnecting pipes take the necessary line pressure to each of the servos which control brake band operation in manual and automatic selector positions.

Fa.2

The power flow through the bevel reductions gear is coupled to the final drive gear pinion by means of two multi-disc clutch assemblies operated hydraulically in manual and the automatic selector positions.

In the event of tow-starting the engine, an auxiliary oil pump of low capacity is employed which is responsive to vehicle speed only; immediately the engine starts the main pump automatically takes over.

The governor system

The governor is driven by the auxiliary pump gears and is of the spring-loaded mechanical type, with its bobweights mounted on short links. A rod linkage transfers the movement to the governor valve incorporated in the valve block chest.

A spring-loaded rod connected to the carburetter provides an over-ride device. The spring tends to be compressed by accelerator pedal operation, and transfers this load by levers to the governor. The effect is to delay travel of the governor, which in turn delays gear shifts more as the accelerator is depressed.

The torque converter

This is fitted onto a taper on the rear of the crankshaft. Basically it comprises three elements, i.e. an impeller, a turbine, and a stator, but it is only serviced as a unit.

There is a continuous supply of oil circulating through the unit; this assists in dissipating the heat generated, and the out-flow passes through a low-pressure valve which maintains a 30 lb./sq. in. (2.1 kg./cm.²) pressure within the converter to improve efficiency.

The brake bands and servos

Three brake bands are used. One is for reverse and the others provide second and third speed reactions. The clamping load is applied by three hydraulic servos in a common casing.

The multi-disc clutches

For forward motion a single-piston multi-disc clutch carries the drive and is engaged at all times during forward motion of the car. This forward clutch unit is fitted on one side of the final drive pinion and on the other side is a top and reverse clutch assembly which has a tandem piston arrangement. This feature is necessary because the clutch is also engaged for reverse and since a greater torque capacity is required in this case both pistons are pressurized.

The valve block

This assembly is constructed of three sections, i.e. the lid, valve chest, and pipe chest.

A linkage arrangement locates the selector valve and this in turn is controlled by the selector rod, externally connected by cable to the gear selector lever in the car. The function of the various valves is as follows:

The selector valve, directs oil from the main supply to either the governor valve for automatic gear-shifting or alternatively to the appropriate clutch or servo for manual selection.

The regulator valve controls the main line pressure, a secondary piston on the valve boosts this pressure when reverse is selected.

The governor valve movement is controlled by the mechanical governor and it directs the oil flow to the appropriate clutch or servo for automatic gear-shifts.

The relay valves are used for shifts from second to third and third to top. They enable the clutch or servo required to be supplied either from the selector valve in 'manual' control or the governor valve in 'automatic'. In addition, pistons are fitted in front of the second and third relay valves to ensure that on up-shifts the engagement of the new ratio and release of the old occur simultaneously to prevent engine overspeeding between shifts. A relay valve is not required for the first gear as the torque reaction is controlled mechanically by a one-way clutch.

The tow-start valve short-circuits the auxiliary pump under all normal driving conditions but supplies the required line pressure for tow-starting. Immediately the engine starts the main pump automatically takes over.

The low-pressure valve

This valve controls the pressure in the converter to 30 lb./sq. in. (2.1 kg./cm.²). When the engine is stopped the valve is seated, preventing the converter draining. This avoids difficulties in checking the combined engine/transmission oil level and prevents a noisy and inefficient converter when restarting the engine.

The auxiliary pump

This unit is used for tow-starting. It is of limited capacity and is responsive to road speed only.

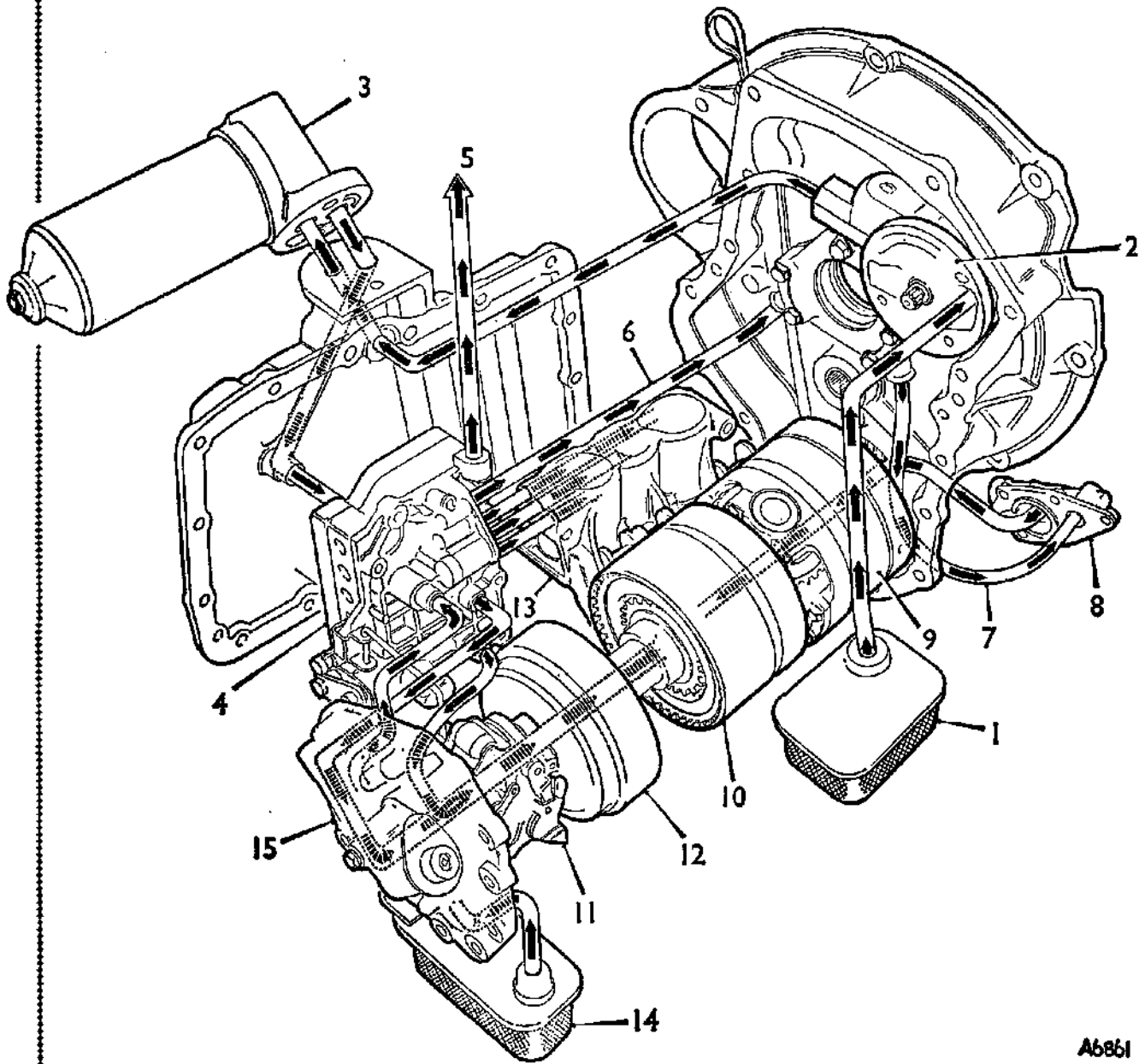

A6861

The components of the automatic transmission with the lubrication system and 'power flow' indicated by arrows to the various components

- | | | |
|-------------------------|--|----------------------------------|
| 1. Main oil strainer. | 6. Converter feed pipe. | 11. Governor. |
| 2. Oil pump. | 7. Converter to low pressure valve feed. | 12. Forward clutch. |
| 3. Oil filter assembly. | 8. Low pressure valve. | 13. Servo unit. |
| 4. Valve block. | 9. Gear train. | 14. Auxiliary pump oil strainer. |
| 5. Engine oil feed. | 10. Top and reverse clutch. | 15. Auxiliary pump. |

POWER FLOW DIAGRAMS (MECHANICAL)

The power flow diagrams indicate how the various ratios are obtained. Four speeds and reverse are provided and these are brought into operation by engaging the appropriate friction members.

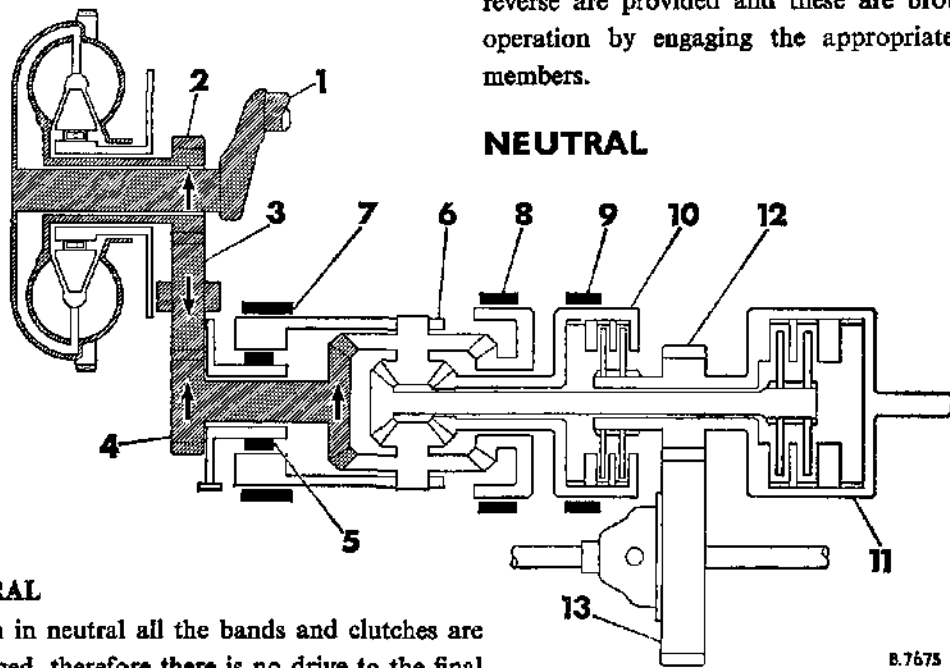

NEUTRAL

When in neutral all the bands and clutches are disengaged, therefore there is no drive to the final drive pinion.

B.7675

KEY TO COMPONENTS

- | | |
|---------------------------|-----------------------------|
| 1. Crankshaft | 8. Third gear band. |
| 2. Converter output gear. | 9. Second gear band. |
| 3. Idler gear. | 10. Top and reverse clutch. |
| 4. Input gear. | 11. Forward clutch. |
| 5. One-way clutch. | 12. Final drive pinion. |
| 6. Gear carrier. | 13. Final drive gear. |
| 7. Reverse band. | |

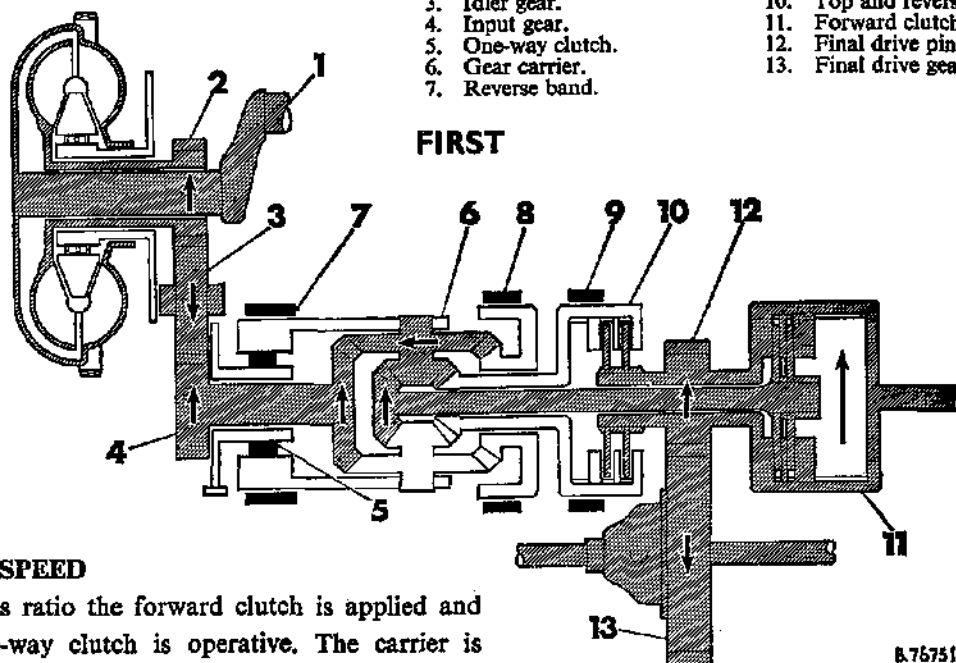

FIRST

FIRST SPEED

In this ratio the forward clutch is applied and the one-way clutch is operative. The carrier is stationary, its reaction being controlled by the one-way clutch. The input bevel drives the planet wheels and the planet pinions drive the forward output pinion and shaft. Thus power is transferred through the planet assemblies to the mainshaft, forward clutch, and the output gear, providing a ratio of 2.69 : 1.

B.76751

POWER FLOW DIAGRAMS (MECHANICAL)

SECOND SPEED

As for all forward gears the forward clutch remains engaged, and in addition the second speed brake band applied. This controls the reaction which is imposed on the reverse drive bevel when in this ratio. With the planet cluster orbiting around the reverse drive bevel power is transmitted from the input bevel through the planets to the mainshaft and provides a ratio of 1.845 : 1.

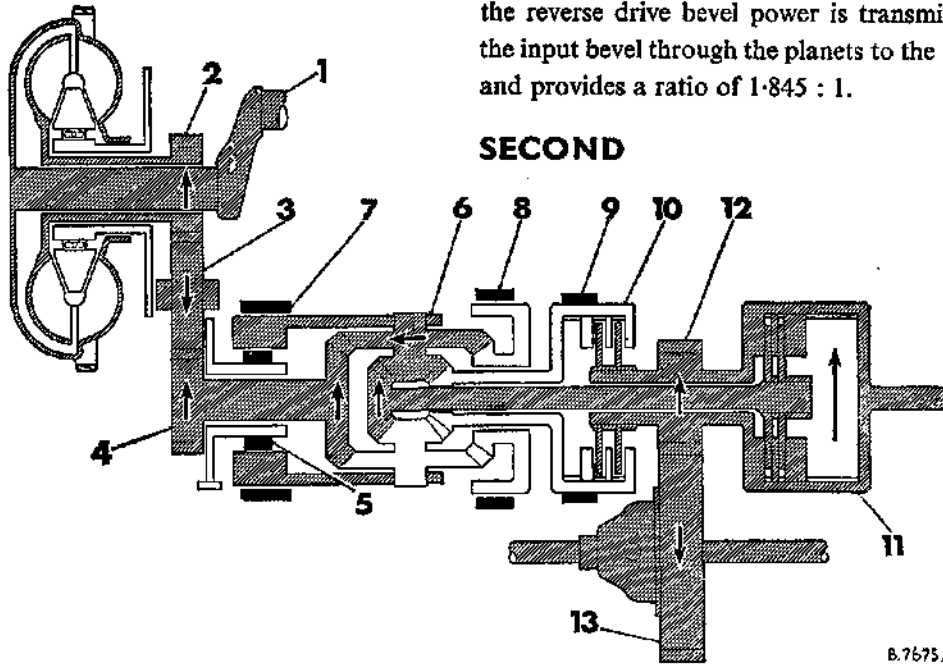

B.76752

SECOND

KEY TO COMPONENTS

- | | |
|---------------------------|-----------------------------|
| 1. Crankshaft. | 8. Third gear band. |
| 2. Converter output gear. | 9. Second gear band. |
| 3. Idler gear. | 10. Top and reverse clutch. |
| 4. Input gear. | 11. Forward clutch. |
| 5. One-way clutch. | 12. Final drive pinion. |
| 6. Gear carrier. | 13. Final drive gear. |
| 7. Reverse band. | |

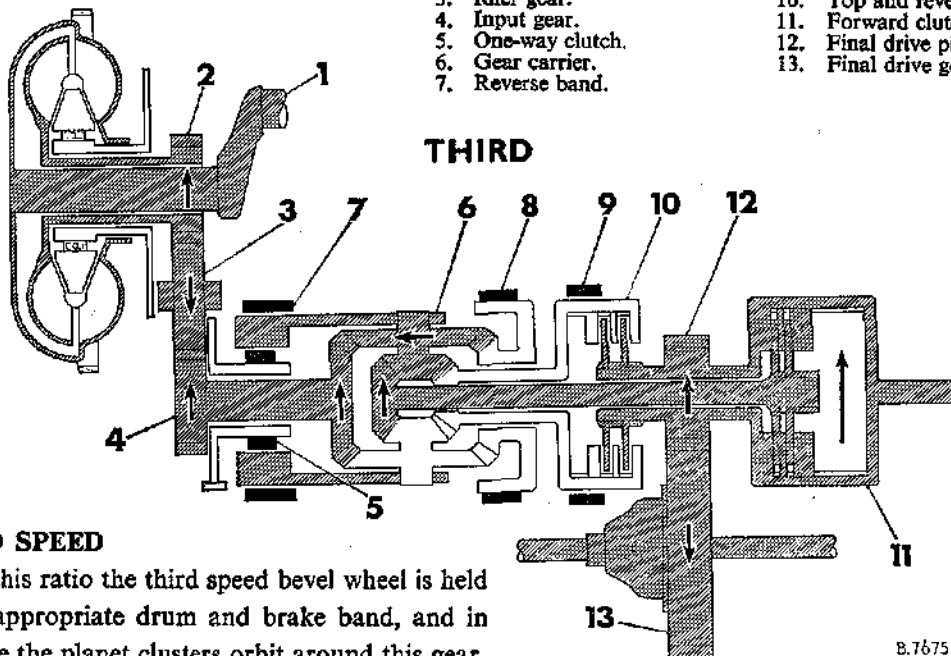

B.76755

THIRD SPEED

For this ratio the third speed bevel wheel is held by its appropriate drum and brake band, and in this case the planet clusters orbit around this gear. Like second speed, power is transmitted from the input bevel through the planets to the mainshaft and in this case provides a ratio of 1.46 : 1.

POWER FLOW DIAGRAMS (MECHANICAL)

TOP SPEED

In addition to the forward clutch, the top and reverse clutch is engaged. This in effect locks up the bevel gears and the reduction gear assembly then rotates as one unit to provide direct drive.

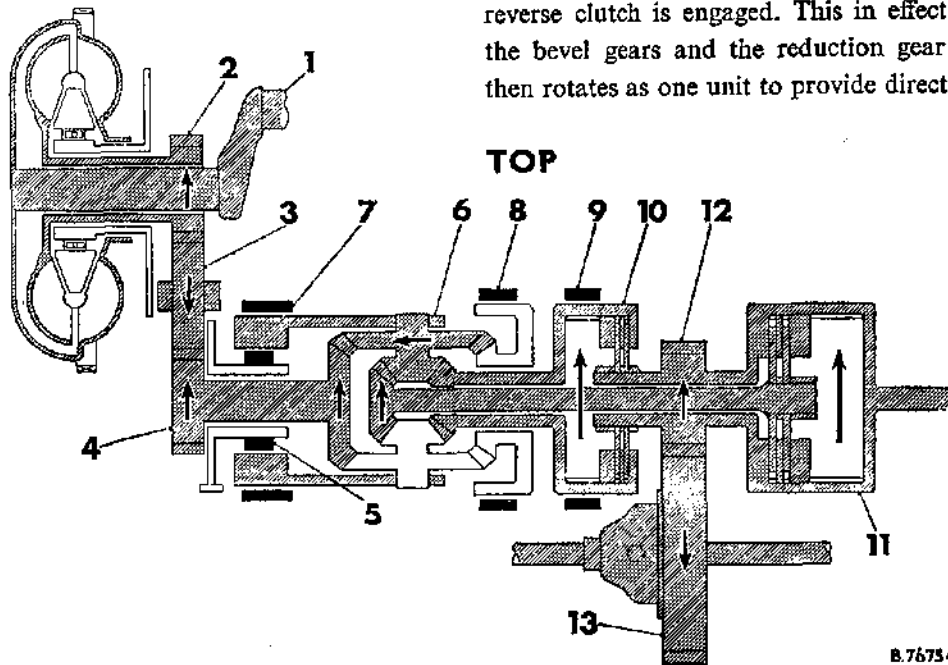

B.76734

KEY TO COMPONENTS

- | | |
|---------------------------|-----------------------------|
| 1. Crankshaft. | 8. Third gear band. |
| 2. Converter output gear. | 9. Second gear band. |
| 3. Idler gear. | 10. Top and reverse clutch. |
| 4. Input gear. | 11. Forward clutch. |
| 5. One-way clutch. | 12. Final drive pinion. |
| 6. Gear carrier. | 13. Final drive gear. |
| 7. Reverse band. | |

REVERSE

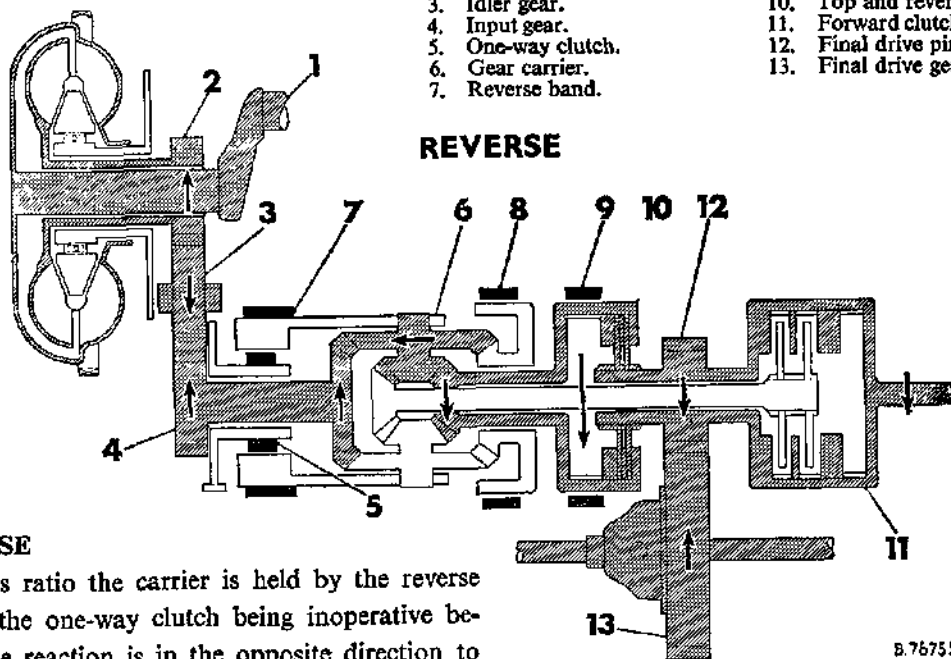

B.76755

REVERSE

In this ratio the carrier is held by the reverse band—the one-way clutch being inoperative because the reaction is in the opposite direction to first speed).

In addition the top and reverse clutch is engaged.

The input bevel wheel drives the planet wheel and the planet pinion drives the reverse drive gear. Thus power is transmitted through the planet assemblies to the top and reverse clutch and thence to the final drive pinion to provide a ratio of 2.69 : 1.

LINE PRESSURE AND LUBRICATION DIAGRAMS

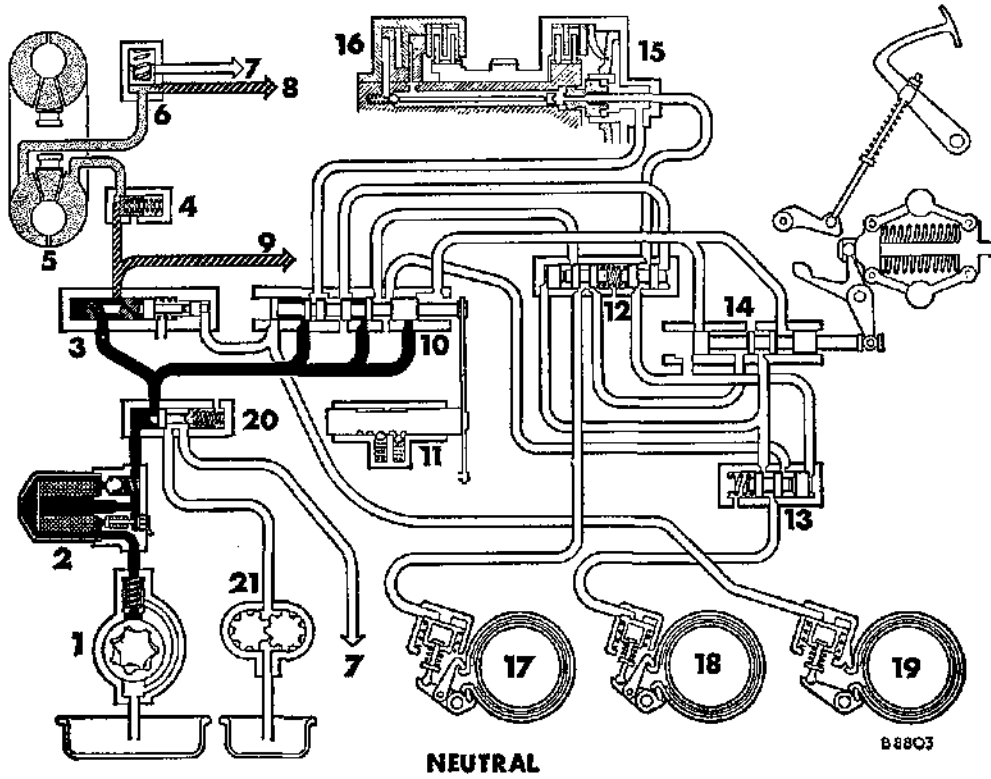

KEY TO DIAGRAM

- | | |
|-------------------------------------|---------------------------------|
| 1. Main oil pump. | 12. Second and top gear valves. |
| 2. Oil filter. | 13. Third gear valve. |
| 3. Regulator valve. | 14. Governor valve. |
| 4. Engine lubrication relief valve. | 15. Forward clutch. |
| 5. Converter. | 16. Top and reverse clutch. |
| 6. Low pressure valve. | 17. Second gear brake band. |
| 7. Engine lubrication. | 18. Third gear brake band. |
| 8. Gear train lubrication. | 19. Reverse gear brake band. |
| 9. Engine lubrication. | 20. Tow start valve. |
| 10. Selector valve. | 21. Auxiliary pump. |
| 11. Selector valve detent. | |

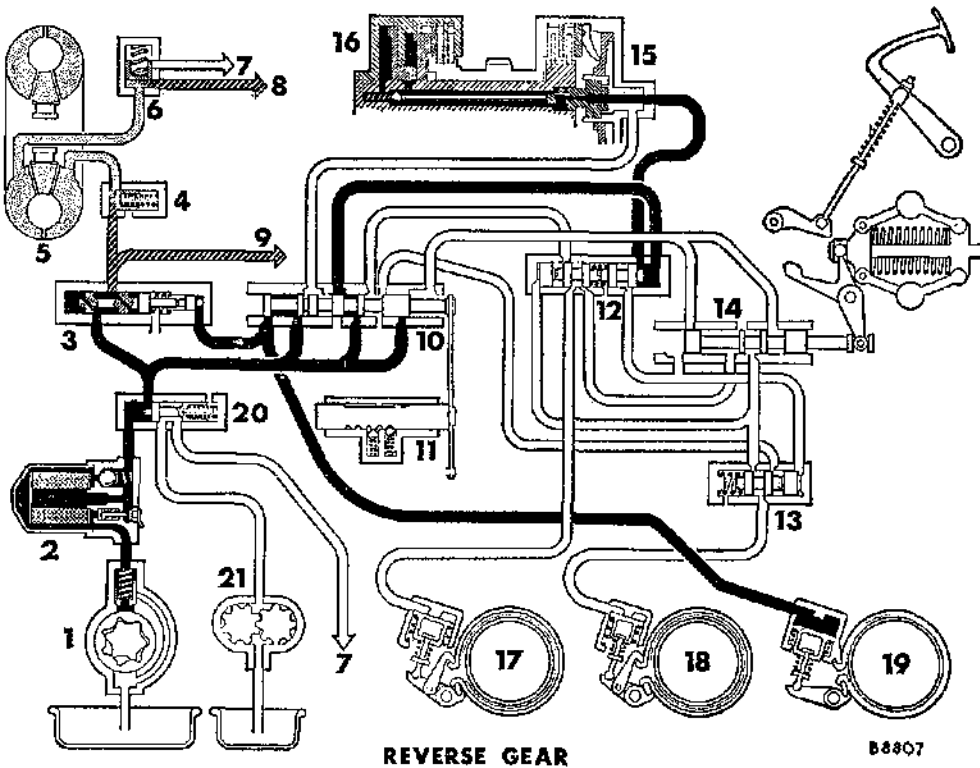
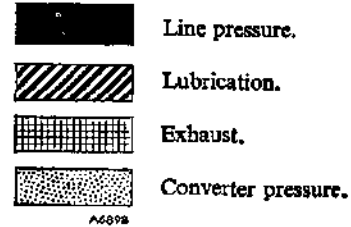

LINE PRESSURE AND LUBRICATION DIAGRAMS

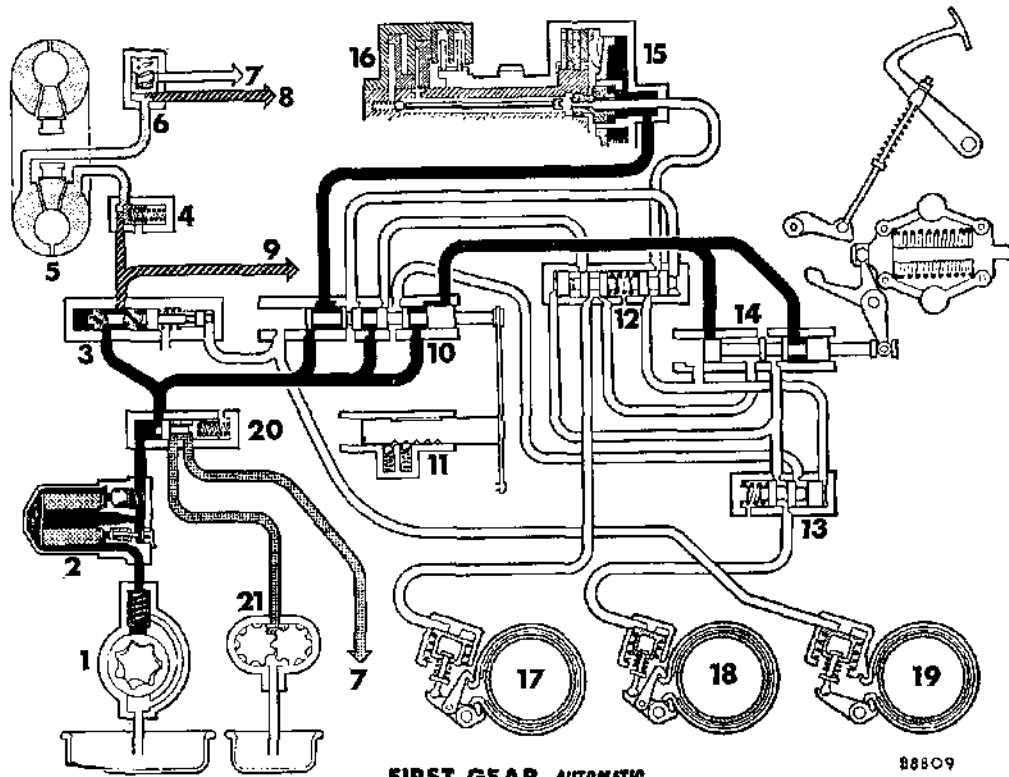

FIRST GEAR *AUTOMATIC*

88809

KEY TO DIAGRAM

- | | |
|-------------------------------------|---------------------------------|
| 1. Main oil pump. | 12. Second and top gear valves. |
| 2. Oil filter. | 13. Third gear valve. |
| 3. Regulator valve. | 14. Governor valve. |
| 4. Engine lubrication relief valve. | 15. Forward clutch. |
| 5. Converter. | 16. Top and reverse clutch. |
| 6. Low pressure valve. | 17. Second gear brake band. |
| 7. Engine lubrication. | 18. Third gear brake band. |
| 8. Gear train lubrication. | 19. Reverse gear brake band. |
| 9. Engine lubrication. | 20. Tow start valve. |
| 10. Selector valve. | 21. Auxiliary pump. |
| 11. Selector valve detent. | |

- | | |
|--|--------------------|
| | Line pressure. |
| | Lubrication. |
| | Exhaust. |
| | Converter pressure |

A6678

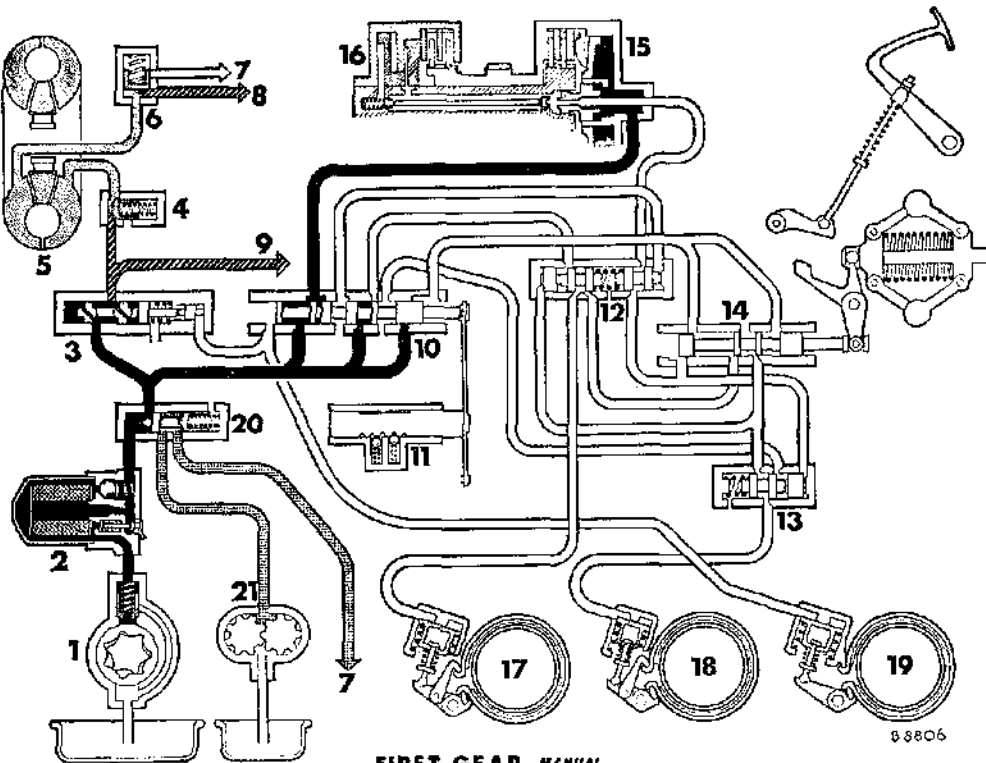



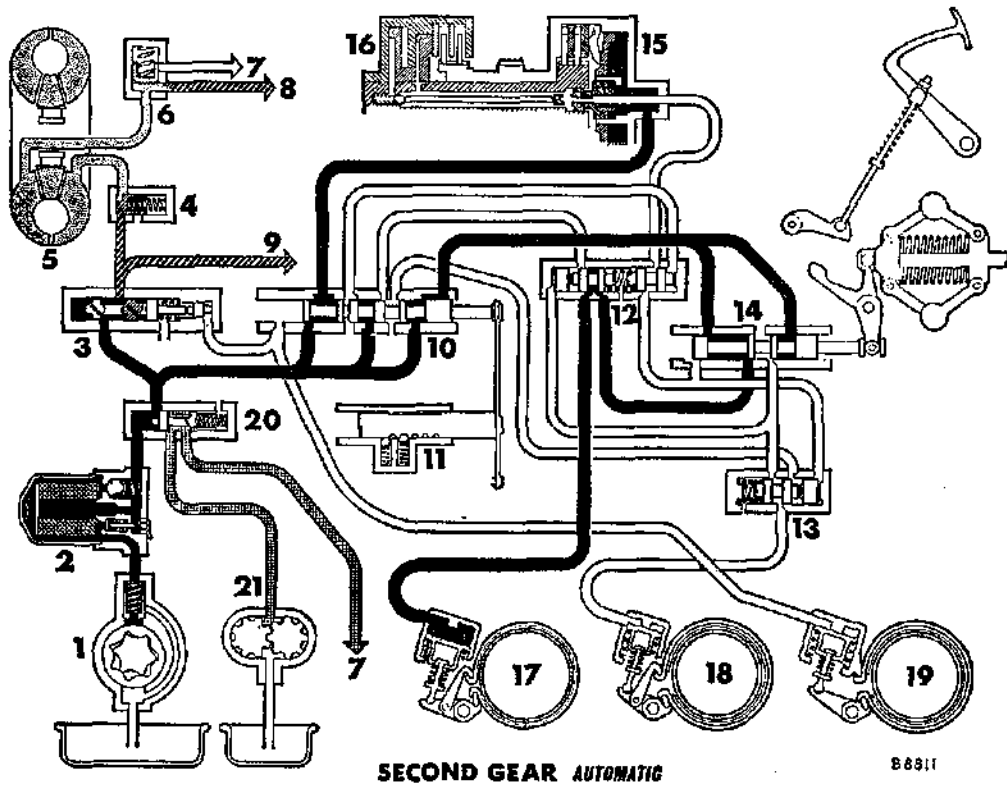

FIRST GEAR *MANUAL*

88806

LINE PRESSURE AND LUBRICATION DIAGRAMS



KEY TO DIAGRAM

- | | | |
|-------------------------------------|---------------------------------|--|
| 1. Main oil pump. | 12. Second and top gear valves. |  Line pressure. |
| 2. Oil filter. | 13. Third gear valve. |  Lubrication. |
| 3. Regulator valve. | 14. Governor valve. |  Exhaust. |
| 4. Engine lubrication relief valve. | 15. Forward clutch. |  Converter pressure. |
| 5. Converter. | 16. Top and reverse clutch. | |
| 6. Low pressure valve. | 17. Second gear brake band. | |
| 7. Engine lubrication. | 18. Third gear brake band. | |
| 8. Gear train lubrication. | 19. Reverse gear brake band. | |
| 9. Engine lubrication. | 20. Tow start valve. | |
| 10. Selector valve. | 21. Auxiliary pump. | |
| 11. Selector valve detent. | | |
- A6898

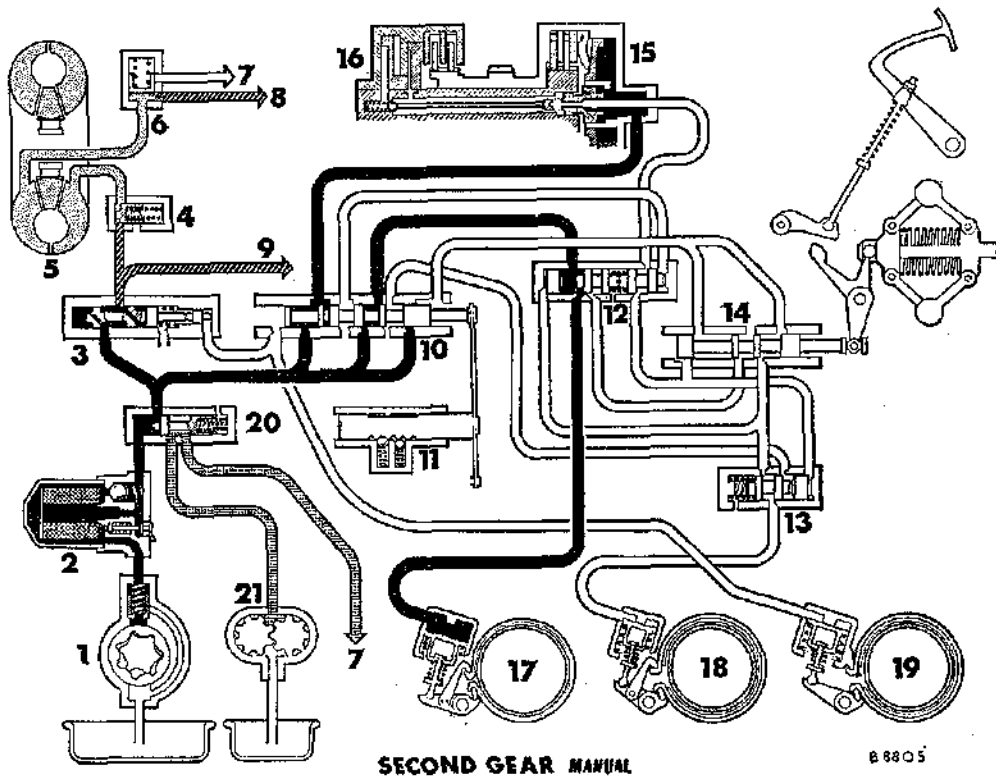

LINE PRESSURE AND LUBRICATION DIAGRAMS

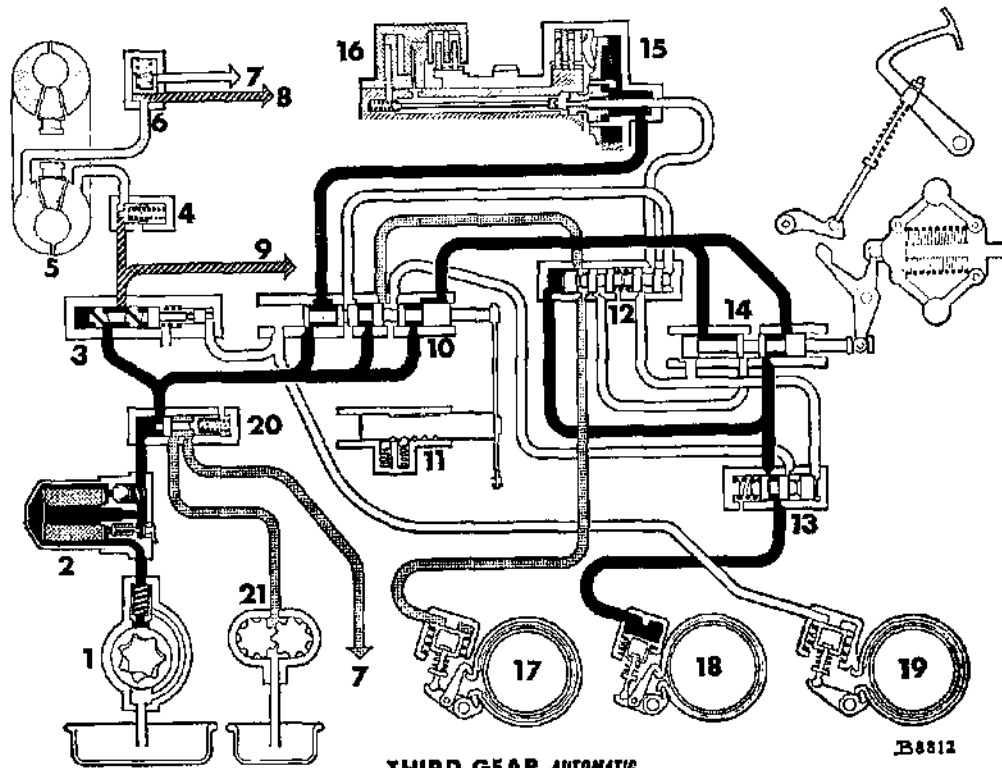

THIRD GEAR AUTOMATIC

B8812

KEY TO DIAGRAM

- | | |
|-------------------------------------|---------------------------------|
| 1. Main oil pump. | 12. Second and top gear valves. |
| 2. Oil filter. | 13. Third gear valve. |
| 3. Regulator valve. | 14. Governor valve. |
| 4. Engine lubrication relief valve. | 15. Forward clutch. |
| 5. Converter. | 16. Top and reverse clutch. |
| 6. Low pressure valve. | 17. Second gear brake band. |
| 7. Engine lubrication. | 18. Third gear brake band. |
| 8. Gear train lubrication. | 19. Reverse gear brake band. |
| 9. Engine lubrication. | 20. Tow start valve. |
| 10. Selector valve. | 21. Auxiliary pump. |
| 11. Selector valve detent. | |

- | | |
|--|---------------------|
| | Line pressure. |
| | Lubrication. |
| | Exhaust. |
| | Converter pressure. |

A4898

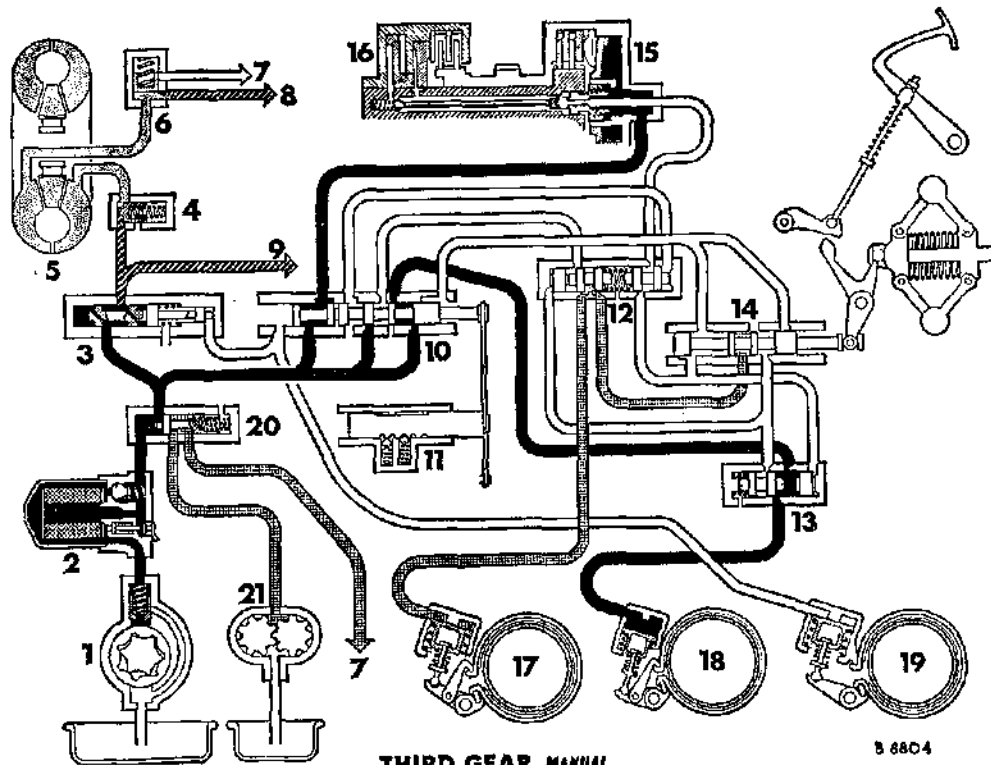

THIRD GEAR MANUAL

B 6804

LINE PRESSURE AND LUBRICATION DIAGRAMS

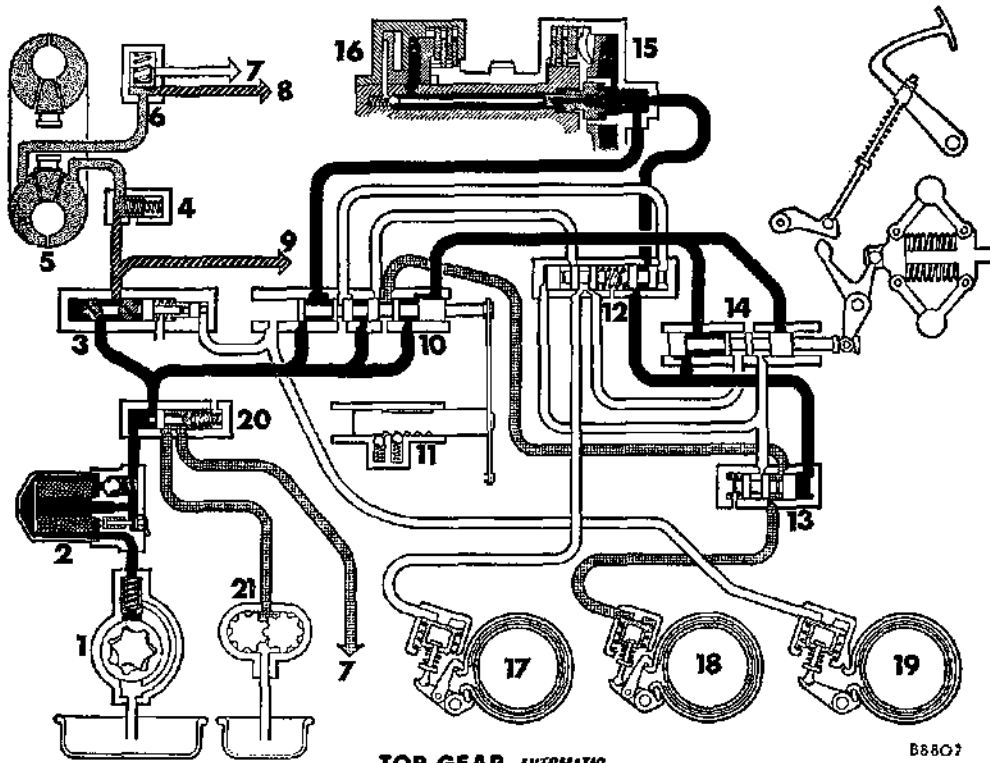

TOP GEAR AUTOMATIC

B8807

KEY TO DIAGRAM

- | | |
|-------------------------------------|---------------------------------|
| 1. Main oil pump. | 12. Second and top gear valves. |
| 2. Oil filter. | 13. Third gear valve. |
| 3. Regulator valve. | 14. Governor valve. |
| 4. Engine lubrication relief valve. | 15. Forward clutch. |
| 5. Converter | 16. Top and reverse clutch. |
| 6. Low pressure valve. | 17. Second gear brake band. |
| 7. Engine lubrication. | 18. Third gear brake band. |
| 8. Gear train lubrication. | 19. Reverse gear brake band. |
| 9. Engine lubrication. | 20. Tow start valve. |
| 10. Selector valve. | 21. Auxiliary pump. |
| 11. Selector valve detent. | |

- | | |
|--|--------------------|
| | Line pressure. |
| | Lubrication. |
| | Exhaust. |
| | Converter pressure |

A4878

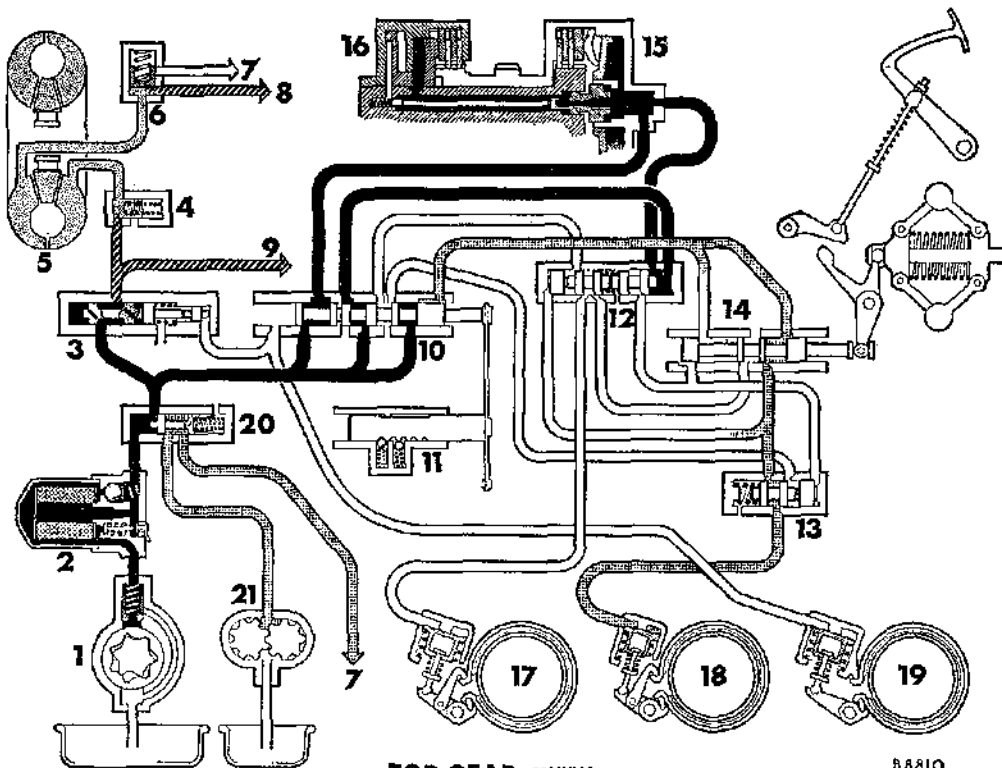

TOP GEAR MANUAL

B8810

LINE PRESSURE AND LUBRICATION DIAGRAMS

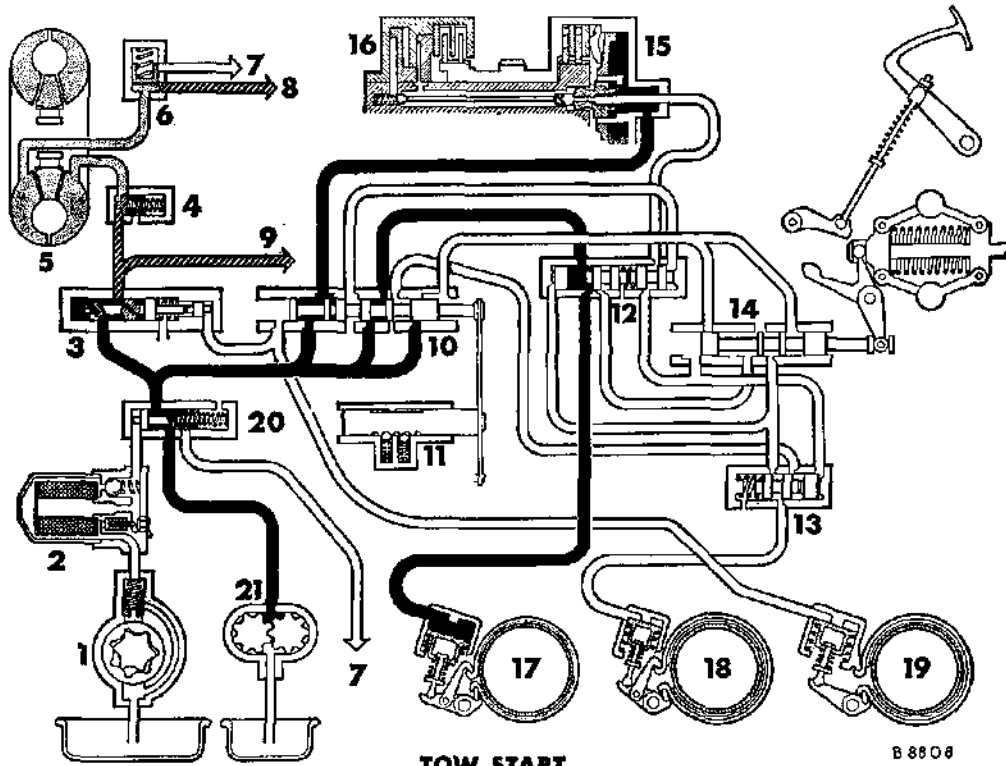





TOW START

B 8806

KEY TO DIAGRAM

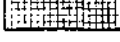
- | | |
|-------------------------------------|---------------------------------|
| 1. Main oil pump | 12. Second and top gear valves. |
| 2. Oil filter. | 13. Third gear valve. |
| 3. Regulator valve. | 14. Governor valve. |
| 4. Engine lubrication relief valve. | 15. Forward clutch. |
| 5. Converter. | 16. Top and reverse clutch |
| 6. Low pressure valve. | 17. Second gear brake band. |
| 7. Engine lubrication. | 18. Third gear brake band. |
| 8. Gear train lubrication. | 19. Reverse gear brake band. |
| 9. Engine lubrication. | 20. Tow start valve. |
| 10. Selector valve. | 21. Auxiliary pump. |
| 11. Selector valve detent. | |

- | | |
|---|---------------------|
|  | Line pressure. |
|  | Lubrication. |
|  | Exhaust. |
|  | Converter pressure. |

A6898

Section Fa.1

FAULT DIAGNOSIS

Road test procedure

It is important to carry out a road test in all cases of suspected faults in order to confirm which component(s) of the automatic transmission are faulty or require adjustment.

In suspected cases of slip or poor acceleration a converter stall speed test should be carried out as detailed in Section Fa.2.

Check the performance in all seven selector positions as given below:

Neutral

Check that there is key start in this position only, and not in the drive positions.

Manual 1

Confirm that there is drive with NO engine braking.

Manual 2, 3, 4

Confirm that there is drive WITH engine braking.

Drive (automatic)

Check the speeds at which all up-and down-shifts are changing (these are detailed below on the 'CHANGE SPEED CHART').

Reverse

Confirm that there is drive WITH engine braking.

NOTE.—In suspected cases of faulty transmission gears and/or clutch units, a stall speed test should be carried out in all gears to determine which of the clutch units and/or brake bands are faulty. The mechanical power flow diagrams indicate the components in use for each gear. If there is slip in all gears a low oil pressure is indicated which should be confirmed by a pressure check as detailed in Section Fa.2.

CHANGE SPEED CHART

| Selector Position | Throttle Position | Gear Shift | M.P.H. | Km.P.H. |
|-------------------|----------------------|------------|--------|---------|
| 'D' | Light | 1-2 | 10-14 | 16-22 |
| | | 2-3 | 15-19 | 24-30 |
| | | 3-4 | 20-24 | 32-39 |
| 'D' | Kick-down | 1-2 | 25-33 | 40-53 |
| | | 2-3 | 37-45 | 60-72 |
| | | 3-4 | 49-57 | 78-91 |
| 'D' | Kick-down | 4-3 | 43-39 | 70-64 |
| | | 3-2 | 35-31 | 56-50 |
| | | 2-1 | 22-18 | 35-29 |
| 'D' | Closed (roll out) | 4-3 | 20-16 | 32-26 |
| | | 3-2 | 14-10 | 22-16 |
| | | 2-1 | 8-4 | 12-6 |

FAULT DIAGNOSIS

| <i>Faults</i> | <i>Diagnosis and Rectification Sequence</i> |
|---|---|
| Faulty gear selection, possibly with tie-up in 'D' position on kick-down | 1 |
| Slip or no drive in forward gears | 2, 3 |
| Slip in reverse | 4, 5, 6 |
| Slip or no drive in all gears | 7, 8, 13, 20, 23 |
| Difficult or bumpy selection and shifts possibly with squawk on selection and with lubrication warning light on or low gauge pressure | 7, 8, 9, 13, 20 |
| Erratic automatic shifts | 7, 10 |
| Incorrect shift speeds | 11 |
| Excessive creep or engine stalls when selecting gear | 12 |
| Unable to tow-start | 13, 14 |
| Gear whine consistent with road speed but not in 'top' gear (4) | 15 |
| Continual whine consistent with engine speed | 16 |
| No drive in 'first' gear (1) automatic and manual | 17, 18 |
| Slip or no drive in 'second' gear (2) automatic and manual | 19 |
| No drive in 2, 3, or 4 positions manual but drives in these gears on automatic 'D' | 13 |
| No drive in 2, 3, or 4 automatic 'D' positions, but drives in these gears on manual selection | 13 |
| Poor acceleration | 21 |
| Reduced maximum speed in all gears with severe converter overheating | 22 |

DIAGNOSIS AND RECTIFICATION CHART

| | |
|----|---|
| 1 | Check gear change cable and selector rod adjustment (Section Fa.2). |
| 2 | Check the fitting of forward clutch feed pipe (Section Fa.3). |
| 3 | Check the forward clutch and/or the shaft rings (Section Fa.6). |
| 4 | Check the reverse gear band adjustment or remove the valve block and check the reverse servo feed pipe 'O' ring seals (Section Fa.4). |
| 5 | Remove the valve block and clean; regulator valve or reverse booster piston faulty (Section Fa.4). |
| 6 | Check the top and reverse clutch booster piston or shut-off valve (Section Fa.10). |
| 7 | Check engine/transmission oil level (Section Aa.1). |
| 8 | Carry out pressure check (Section Fa.2). |
| 9 | Check oil filter head 'O' ring seals or fitting of joint washer (Section Aa.2). |
| 10 | Remove and examine governor unit for sticking (Section Fa.5). |
| 11 | Check governor control rod adjustment (Section Fa.2). |
| 12 | Check carburetter adjustment—incorrect idle speed (Section Da.2). |
| 13 | Remove and clean valve block (Section Fa.4). |
| 14 | Check auxiliary pump, pipes, and seals (Section Fa.5). |
| 15 | Check gear train adjustment (Section Fa.7). |
| 16 | Check converter housing bush (Section Aa.4). |
| 17 | Check free-wheel support dowel bolt—sheared (Section Fa.3). |
| 18 | Check the one-way clutch unit (Section Fa.11). |
| 19 | Remove the valve block and check the servo feed pipe 'O' ring seals and check the second gear band adjustment (Section Fa.4). |
| 20 | Check main oil pump and flow valve, the supply and feed pipe seals, and main oil strainer seals (Sections Aa.8 and Fa.3). |
| 21 | Carry out stall speed check (Section Fa.2). |
| 22 | Change the torque converter unit (Section Aa.4). |
| 23 | Check the low pressure valve. |

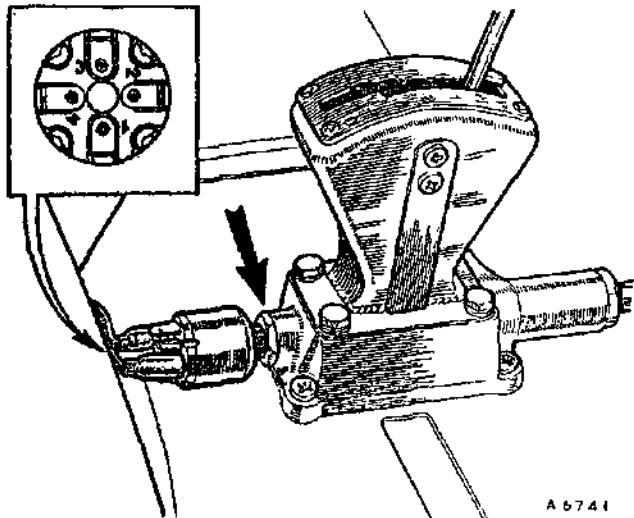

Fig. Fa.1

The inhibitor switch on the gear-change lever housing. Inset, the 1 and 3, 2 and 4 connections marked on the switch. The locking nut is indicated by an arrow

- (6) Verify that the starter operates only when the gear selector lever is in 'N', also that the reversing light (when fitted) operates only when 'R' is selected.

NOTE.—If the switch cannot be adjusted to operate correctly it must be renewed.

Gear-change cable and selector rod

It is most important to carry out the adjustment procedure detailed below and refer to Fig. Fa.2.

Adjustment

- (7) Pull back the rubber boot (1) and remove clevis pin (2). Ensure that the selector rod (3) is screwed in tightly and push it fully into the transmission case.

NOTE.—Never start the engine with the selector rod disconnected.

- (8) Refit the clevis pin (2) into the selector rod yoke (4) and check the measurement given in Fig. Fa.2; adjust if necessary.

Section Fa.2

ADJUSTMENTS

Inhibitor switch

The switch is located on the rear of the gear selector housing (Fig. Fa.1).

It has four terminals, two of which are connected through the ignition/starter circuit. This ensures that the engine will only start when the gear selector is in the 'N' position.

The switch terminals marked 2 and 4 are used in the ignition/starter circuit, and both the electrical leads are interchangeable to the 2 and 4 positions on the switch.

The terminals marked 1 and 3 are used for reversing light connections (when fitted).

Check the gear-change cable and selector rod adjustment before adjusting the inhibitor switch.

Adjustment

- (1) Select 'N'.
- (2) Disconnect the electrical connections from the switch.
- (3) Slacken the locknut and screw the switch in as far as possible.
- (4) Connect a test lamp or meter across the switch terminals 2 and 4. Screw the switch into the housing until the circuit is made and mark the switch body. Continue screwing in the switch and note the number of turns required until the circuit breaks. Remove the test equipment and unscrew the switch from the housing half the number of turns counted.
- (5) Tighten the locknut and refit the electrical leads to the appropriate terminals.

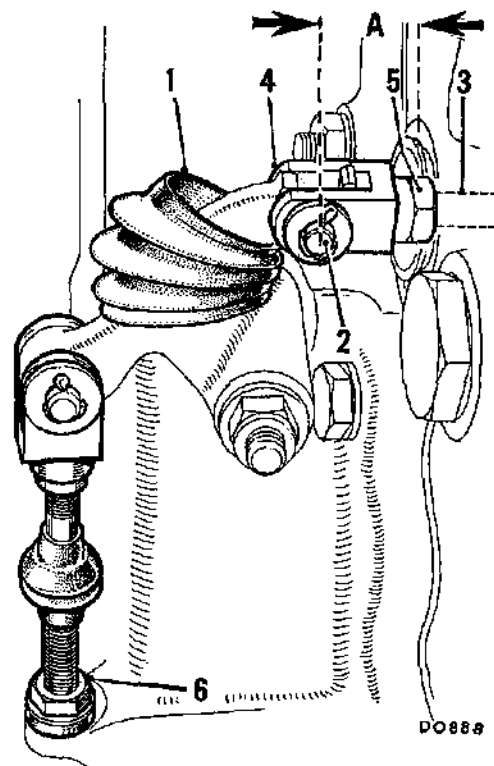

Fig. Fa.2

The gear-change cable and selector rod adjustment

- | | |
|------------------|-------------------------------|
| 1. Rubber boot. | 4. Selector rod yoke. |
| 2. Clevis pin. | 5. Selector rod yoke locknut. |
| 3. Selector rod. | 6. Cable adjusting nuts. |

Shown inset: the selector rod checking dimension.

A = $\frac{3}{8}$ in. (20 mm.)

- (9) Slacken the locknut (5) behind the selector rod yoke and turn the yoke (4) until the correct measurement of $\frac{3}{8}$ in. (20 mm.) is effected (see Fig. Fa.2). Tighten the locknut (5), ensuring that the yoke is set squarely to the bell-crank lever arm.
- (10) Select 'N' in the transmission unit by pulling the selector rod fully out and then pushing it back in one detent.
The measurement 'A' in Fig. Fa.2 should now be 1.45 in. (37 mm.).
- (11) Select 'N' on the quadrant with the gear lever, and adjust the outer cable using the adjusting nuts (6) (see inset to Fig. Fa.2). The adjustment is correct when the clevis pin (2) can be easily refitted.

NOTE.—Ensure that the yoke ends on the selector cable and rod are square to the bell-crank lever, before reconnecting.

Testing adjustment

- (12) Apply the hand and foot brakes, and ensure that the starter operates only in the 'N' position; if this is not correct, adjust the inhibitor switch as detailed in items (1) to (6).
- (13) Start the engine, and move the gear lever to the 'R' position and check that reverse is engaged. Slowly move the lever back towards the 'N' position, checking that the gear is disengaged just before or as soon as the lever drops into the 'N' position on the quadrant. Repeat this procedure in the first gear '1' position. Re-adjust the outer cable slightly if necessary to obtain the above conditions.

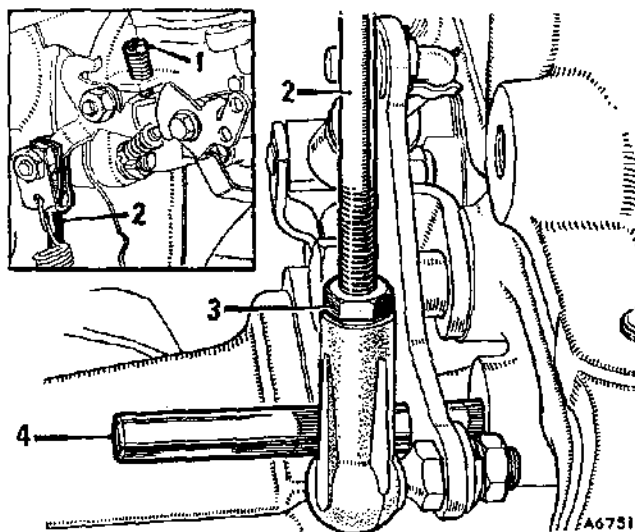

Fig. Fa.3

The governor control rod adjustment showing:

- | | |
|-------------------------------|--|
| 1. Throttle adjustment screw. | 3. Locknut. |
| 2. Governor control rod. | 4. $\frac{1}{4}$ in. (6.4 mm.) diameter rod. |

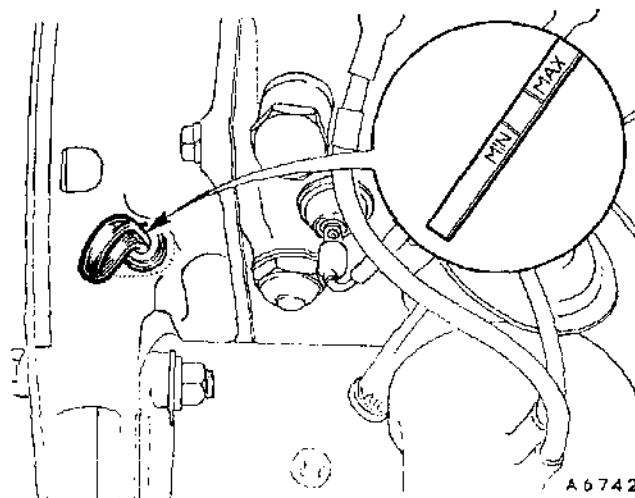

Fig. Fa.4

The oil level dipstick with the level markings shown inset

- (14) Ensure that all adjustment/locking nuts are tight and the clevis pins are secured. Pack the rubber boots with Duckham's Lammol grease. Refit the boots and the weather protection shield (if fitted).
- (15) Carry out a road test, checking the operation in each gear lever position.

Governor control rod adjustment

- (16) Run the engine to its normal working temperature.
- (17) Disconnect the governor control rod at the carburetter.
- (18) With the carburetter correctly tuned, adjust the throttle adjusting screw to give a tachometer reading of 650 r.p.m. at tickover.
- (19) Insert a $\frac{1}{4}$ in. (6.4 mm.) diameter rod through the hole in the governor control rod bell-crank lever and into the hole in the transmission case (Fig. Fa.3).
- (20) Slacken the locknut (3) (Fig. Fa.3) and adjust the length of the rod to suit the carburetter linkage in the tick-over position.
- (21) Reconnect the governor control rod to the carburetter. Tighten the ball joint locknut and remove the checking rod from the bell-crank lever.

Stall speed check

- (22) Start and run the engine until it reaches its normal working temperature and check the oil level.
- (23) Connect a suitable tachometer or that of Service tool 18G 677 or 18G 677 Z (see Fig. Fa.5).

Service tool electrical connections:

18G 677—Green to ignition coil CB.
Red to battery positive.

Black to battery negative.

18G 677 Z—Red to ignition coil CB.

Black to earth connection.

- (24) Apply the hand and foot brakes, select any gear position except 'N' or 1, apply maximum throttle for not more than 10 seconds and note the tachometer reading. Compare the figure obtained with the chart below.

| Model | R.P.M. | Condition | Rectification |
|-----------------------|-------------|------------------------|--|
| 848 c.c. | 1,300-1,400 | Satisfactory | Nil |
| 998 c.c. | 1,400-1,500 | Satisfactory | Nil |
| | Under 1,000 | Stator free wheel slip | Change torque converter |
| | Over 1,500 | Transmission slip | Check transmission unit (see Road Test note) |
| 848 c.c. and 998 c.c. | Under 1,300 | Engine down for power | Check engine |

- (25) Disconnect the tachometer.

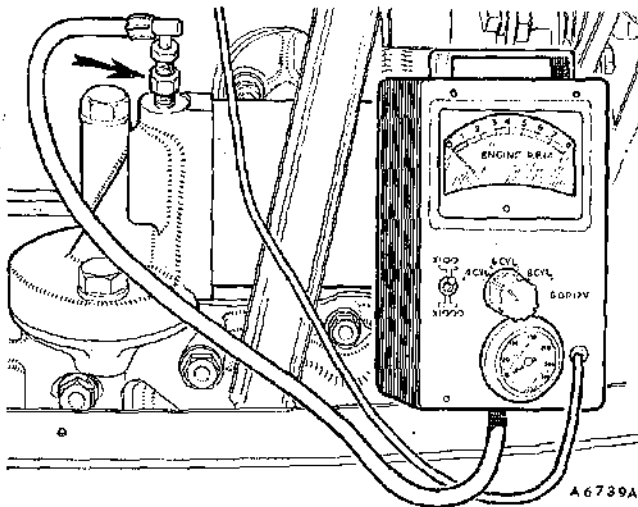

Fig. Fa.5

Checking the pressures and the stall speed with Service tool 18G 677 and adaptor 18G 677 C (arrowed)

Pressure check

- (26) Check and top up the oil level (see Section Aa.1).
- (27) Remove the pressure point plug on the engine oil filter, fit Service tool adaptor 18G 677 C, and connect Service tool 18G 677 Z (see Fig. Fa. 5) or use pressure gauge (Service tool 17G 502 A with pipe and adaptor 18G 502 K).
- (28) Start and run the engine until the oil temperature is 80° C. (176° F.) (check with a thermometer inserted into the dipstick hole). Re-start and run the engine at 1000 r.p.m. and check the following approximate pressures:
- In all gear positions except 'R' a pressure of between 75 and 85 lb./sq. in. (5.3 and 6 kg./cm.²) should register on the gauge.
 - In 'R' the pressure should be between 115 and 125 lb./sq. in. (8 and 8.8 kg./cm.²).

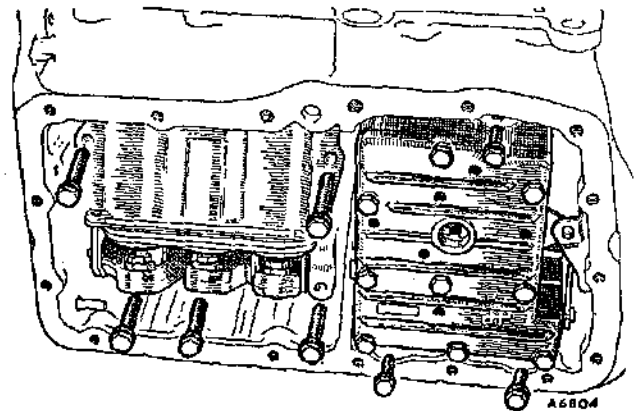

Fig. Fa.6

Removing the valve block and servo bolts

NOTE.—Should the approximate pressures given above not be obtainable, see Section Fa.1, 'FAULT DIAGNOSIS'.

- (29) Remove the pressure test equipment and refit the plug.

Section Fa.3

TRANSMISSION UNIT

Dismantling

- Remove the engine and transmission from the car, see Section Aa.3.
- Remove the transmission from the engine as detailed in Section Aa.4 **only** if fitting a replacement engine, transmission case, or if it is necessary to remove the main oil strainer pick-up pipe and seals.
- Remove the converter and converter housing as detailed in Section Aa.4, items (1) to (11) and (13).

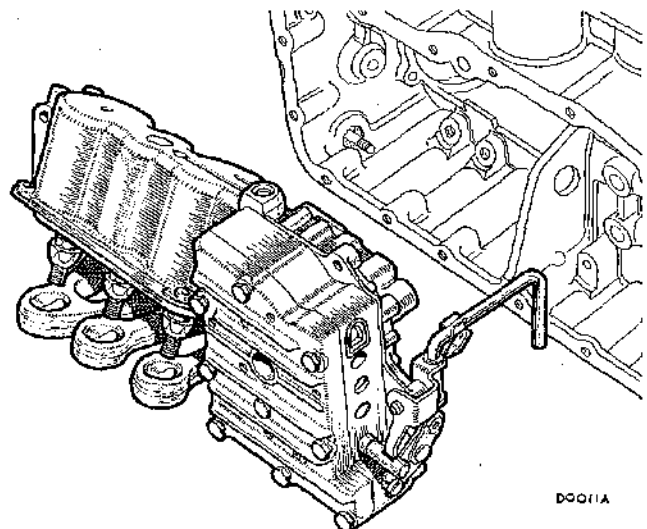

Fig. Fa.7

Removing the valve block and servo unit as an assembly

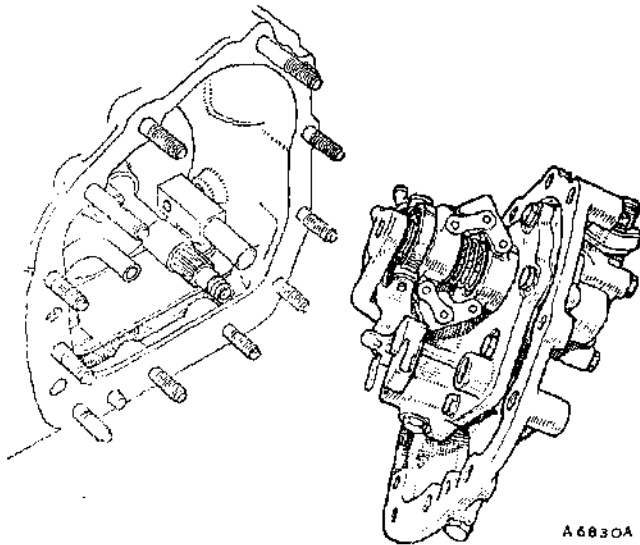

Fig. Fa.8

Removing the auxiliary pump and governor assembly

- (3) Unscrew and withdraw the gear selector rod and remove the front cover (the connecting bobbin is pressed into the later-type cover).
- (4) Remove the governor control assembly from the transmission case and fit Service tool 18G 1097 (see Fig. Fa.19).
- (5) Remove the securing nuts and pull the auxiliary pump and governor assembly from the transmission case.

NOTE.—For auxiliary pump and governor dismantling and reassembling see Section Fa.5.

- (6) Remove the dowel bolt and pull out the auxiliary pump filter outlet pipe.
- (7) Pull out the auxiliary pump outlet and the forward clutch apply pipes.

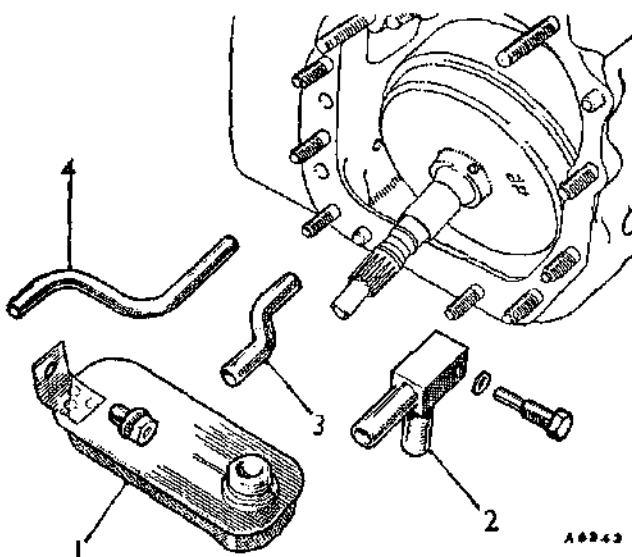

Fig. Fa.9

Removing the auxiliary oil pump strainer (1) and pipe (2), with (3) the outlet pipe, and (4) the forward clutch apply pipe

- (8) Remove the set screw and lift out the auxiliary pump filter.
- (9) Remove Service tool 18G 1097 and withdraw the forward clutch from the casing.

NOTE.—For forward clutch dismantling and reassembling see Section Fa.6.

- (10) Withdraw the forward output shaft and tap out the reverse shut-off valve. Insert the dummy output shaft Service tool 18G 1093 or 18G 1093 A.
- (11) Slacken off the servo band adjusters.
- (12) Remove the dowel bolt (Fig. Fa.11) and remove the gear train which includes the top and reverse clutch with its Torrington needle thrust bearing and steel washer, and the first gear free-wheel assembly.

NOTE.—For gear train dismantling and re-assembling see Section Fa.7.

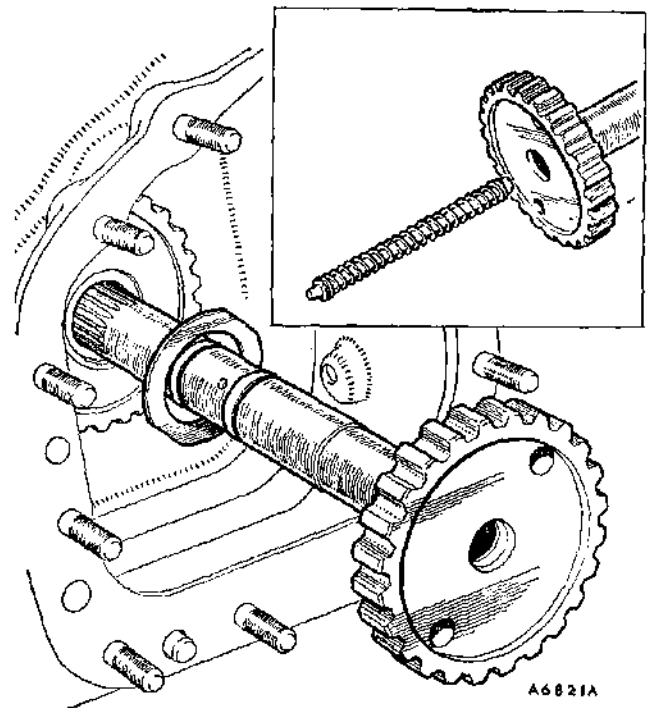

Fig. Fa.10

The forward output shaft with (inset) the reverse shut-off valve

- (13) Remove the valve block and servo unit securing bolts, and on later models unscrew and remove the engine oil feed pipe adaptor and withdraw the valve block connecting pipe through the adaptor hole. Depress the tops of the bands and unhook them from the servos and lift out the valve block and servo unit as an assembly (Fig. Fa.7).

NOTE.—For valve block dismantling and re-assembling see Section Fa.4. For servo unit dismantling and reassembling see Section Fa.8.

- (14) Remove the bands from the transmission case.

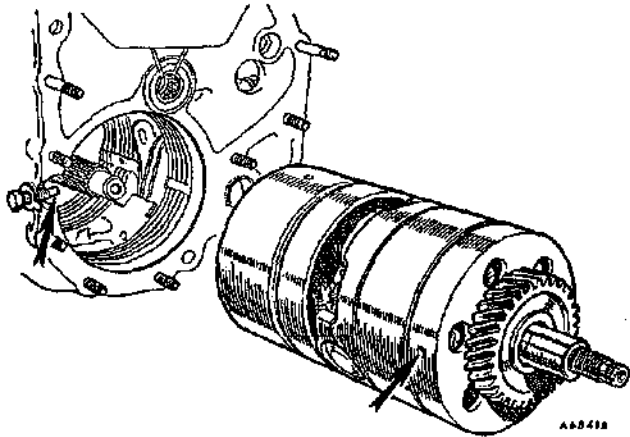

Fig. Fa. 11

Removing the gear train assembly. The arrows indicate the dowel bolt and its location in the free-wheel support

- (15) Remove the governor control assembly from the transmission case. Knock back the lock washers and remove the nuts from the differential housing and the differential end cover set screws. Remove the differential and housing assembly.

NOTE.—For differential dismantling and re-assembling see Section Fa.9.

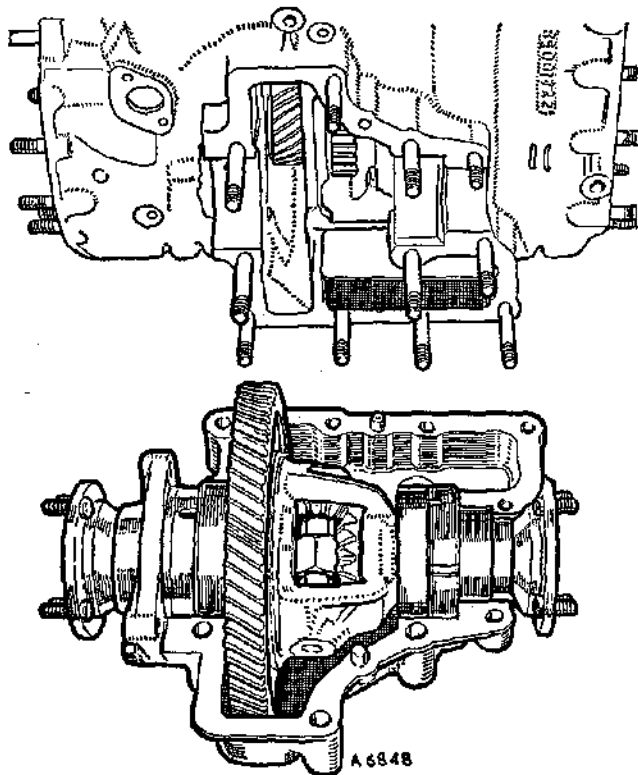

Fig. Fa.12

Removing the differential assembly

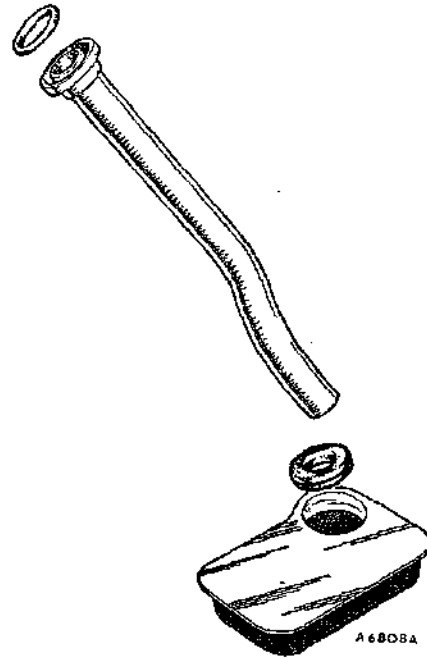

Fig. Fa.13

The main oil strainer, pick-up pipe and seals

- (16) Remove the main oil feed pipe and strainer (see item (2a)).
- (17) Knock back the lock washer on the nut on the forward clutch splines and use Service tool 18G 1095 to hold the top and reverse clutch hub (Fig. Fa.14) and remove the nut with 18G 1096 (Fig. Fa.15). Drift out the top and reverse clutch hub and lift out the piston assembly.

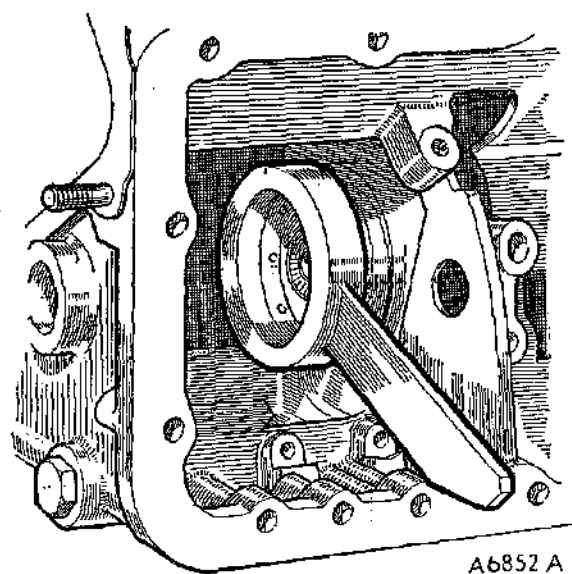

Fig. Fa.14

Using Service tool 18G 1095 to hold the top and reverse splines when removing the forward clutch hub nut

- (18) Remove both the bearings from the centre webs of the transmission case; each bearing must be drifted out on its outer race and from opposing sides of the webs.

Reassembling the transmission unit

Absolute cleanliness is essential, use fuel (petrol) or paraffin (kerosene) where necessary for cleaning. Dry the components with an air pressure line or use non-fluffy rag.

Clean all joint faces and fit new joint washers and oil seals.

After reassembly of each dismantled unit the complete transmission can now be rebuilt.

Lubricate all components with a recommended automatic transmission lubricant. This is particularly important when fitting new 'O' rings and seals.

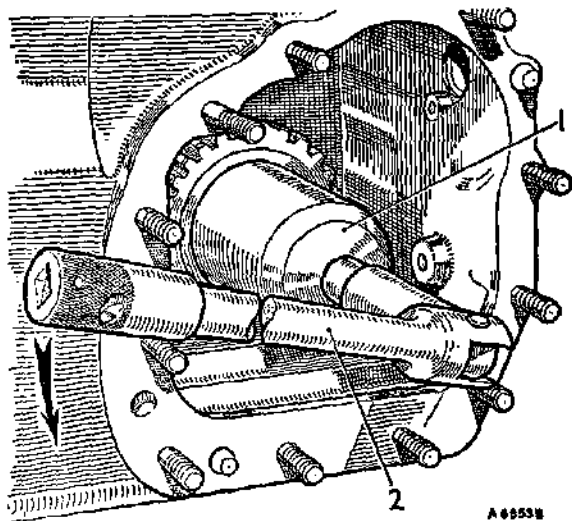

Fig. Fa.15

Removing the forward clutch hub nut

1. Service tool 18G 1096. 2. Socket handle.

- (19) Refit the top and reverse clutch hub bearings to the centre webs of the transmission casing. Drift each bearing on its outer cage into the web until the bearing register contacts the face of the web.
- (20) Refit the top and reverse clutch hub, together with the final drive gear pinion but without the selective washer. Lightly tighten the forward clutch hub nut until light friction is felt on the bearings when rotating the hub.
- (21) Check the gap existing between the final drive gear and the forward clutch hub bearing face.
- (22) Subtract .002 in. (.05 mm.) from the gap measurement and select a washer of this thickness from the range available.
- (23) Remove the hub and refit the assembly with the selected washer and with the chamfer on the final drive pinion facing the gear train (see Fig. Fa.16).

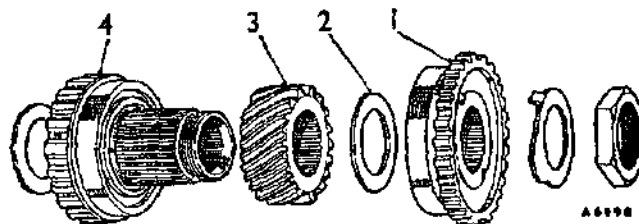
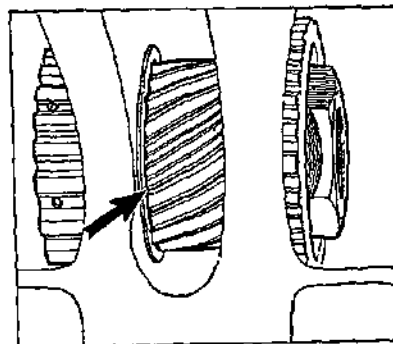

Fig. Fa.16

1. Forward clutch splines. 2. Selective thrust washer. 3. Final drive pinion. 4. Top and reverse splines.

Shown (inset) correctly assembled with the arrow indicating the chamfer on the pinion

- (24) Use Service tool 18G 1095 to hold the top and reverse clutch splines (see Fig. Fa.17) and tighten the forward clutch hub nut with Service tool 18G 1096 and 18G 592 (see Fig. Fa.18), to the torque figure given in 'GENERAL DATA'.
- (25) Check that there is light friction on the bearings when rotating the hub, i.e. the bearings should have a preload of .002 in. (.05 mm.).

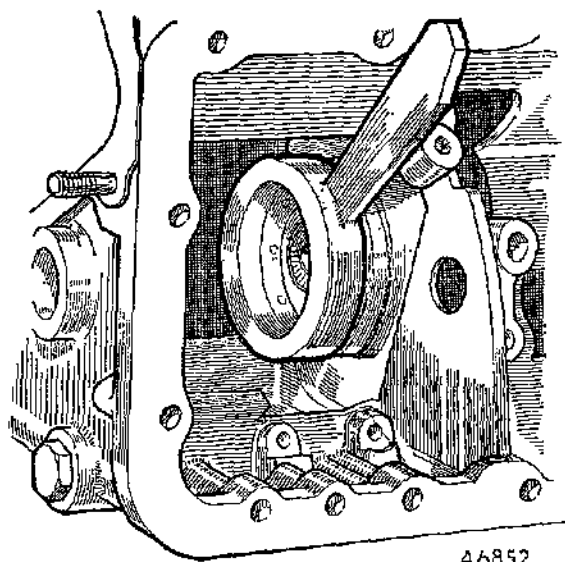

Fig. Fa.17

Using Service tool 18G 1095 to hold the top and reverse splines when tightening the forward clutch hub nut

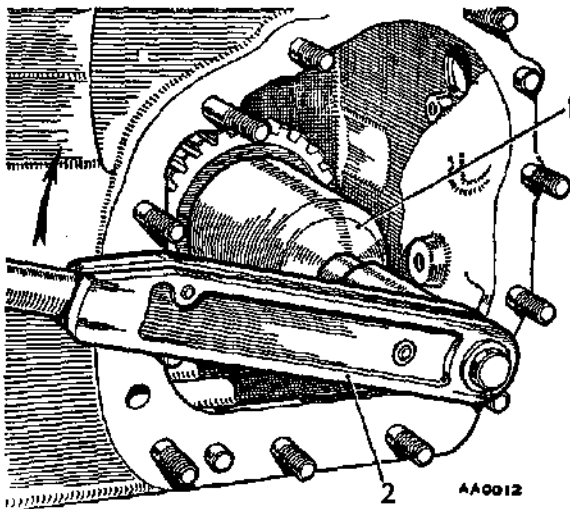

Fig. Fa.18

Tightening the forward clutch hub nut with Service tools 18G 1096 (1) and 18G 592 (2)

- (26) Tap up the locking washer.
- (27) Insert the forward output shaft with its bi-metal washer (see Fig. Fa.10) through the output gear assembly. Ensure that the reverse shut-off valve is located in the end of the shaft, and that the rings on the shaft are in good condition.
- (28) Position the plastic sleeve over the rings on the forward clutch shaft and refit the forward clutch unit. Fit Service tool 18G 1097 to retain the correct position of the forward clutch unit (see Fig. Fa.19).
- (29) Fit new seals to the three valve block bobbins and fit them into their locations in the transmission casing.

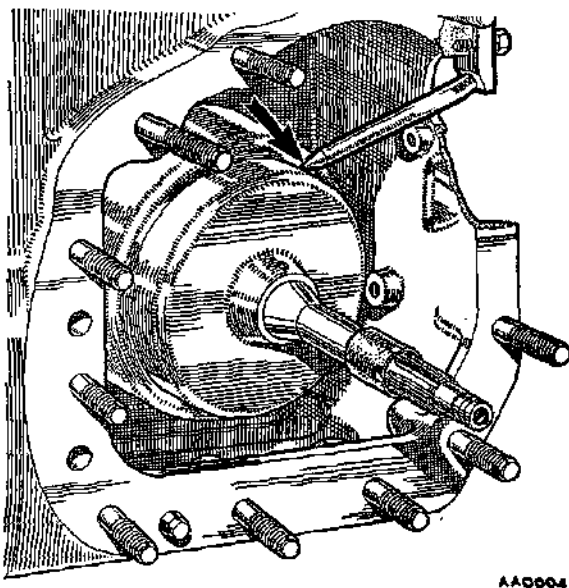

Fig. Fa.19

Holding the forward clutch in position with Service tool 18G 1097

- (30) Reassemble the valve block and servo unit as an assembly, fitting new seals to the inter-connecting pipes.
- (31) Refit the valve block and the servo unit as an assembly into the transmission case, ensuring correct location of the valve block with the bobbins in the case and that the governor linkage is positioned over the web in the transmission casing. Tighten the valve block and the servo unit securing bolts to the torque figure given in 'GENERAL DATA'.
- (32) Refit the second, third, and reverse gear bands into the transmission casing.
- (33) Locate the bands on the servo struts.

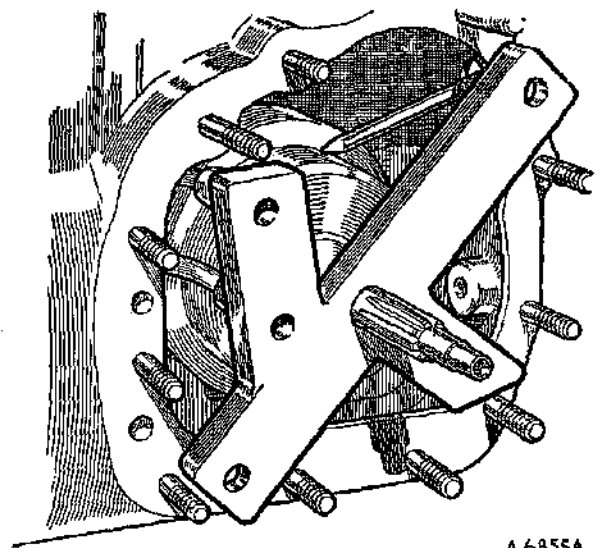

Fig. Fa.20

Using the positioning fixture Service tool 18G 1094 to ensure correct alignment of the pipes

- (34) Refit the forward clutch apply pipe into its location in the transmission casing.
- (35) Refit the auxiliary pump pick-up strainer and pipe; secure the pipe with the dowel bolt (fitted with a copper sealing washer). Refit and tighten the strainer securing screw.
- (36) Fit a new joint washer to the transmission casing. Fit Service tool 18G 1094 and align the pipes (Fig. Fa.20) and remove the tool.
- (37) Refit the auxiliary pump and governor assembly and engage the valve block linkage with the later-type governor unit as shown in Fig. Fa.21, also ensuring correct alignment with the oil pipes and the forward shaft. The plastic sleeve fitted over the rings on the shaft is for assembly purposes, and will become safely displaced along the forward clutch shaft. Tighten the securing nuts to the torque figure given in 'GENERAL DATA'.
- (38) Remove the forward clutch retainer—Service tool 18G 1097.

- (39) Refit the top and reverse clutch hub washer and the Torrington needle thrust bearing into position with grease.
- (40) Ensure that the top and reverse clutch friction plates are free to drop before refitting the gear train assembly into the transmission. Correctly position the second, third, and reverse gear bands in the case and refit the gear train, using hand pressure only to push it into position. Quick rotation of the input gear will assist in engaging the top and reverse clutch friction plates. When correctly reassembled the dowel bolt will engage easily in the freewheel support (Fig. Fa.11).
- (41) Refit the dowel bolt with a new lock washer.

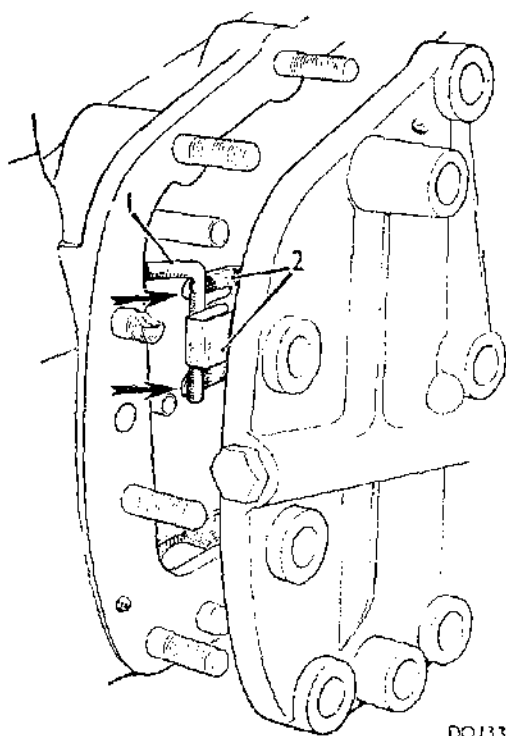

Fig. Fa.21

Engaging the valve block linkage (1) with the spring clip drive mechanism (2) of the later-type governor

- (42) Screw the gear change selector rod fully into the valve block linkage. Check and reset if necessary the selector rod adjustment (see Section Fa.2).
- (43) Adjust the second, third, and reverse servos (see Fig. Fa.23). Slacken the locknut (1) and the spherical adjuster (2) until each brake band (3) is in contact with the transmission casing stops (4). Adjust each adjuster (2) until the clearance 'A' is obtained, and tighten the locking nut (1).
- (44) Fit a new seal to the front cover bobbin, and refit the cover using a new joint washer.
On early units the front cover connecting bobbin can be removed and requires two oil seals.

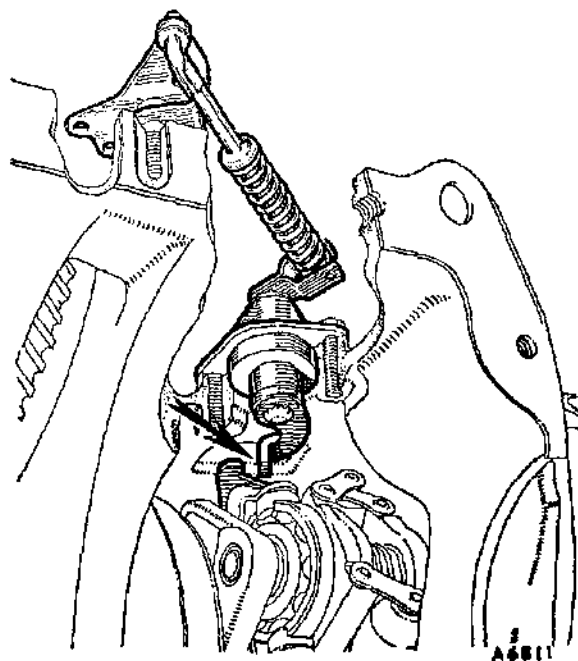

Fig. Fa.22

The correct position of the kick-down rod assembly

- (45) Refit the main oil strainer and pick-up pipe using new seals (if these items were removed), see item (2a).
- (46) Refit the differential assembly as detailed in Section Fa.9.
- (47) Refit the engine to the transmission as detailed in Section Aa.4 (if removed see item (2a)).
- (48) Refit the converter and components removed in item (2b).
- (49) Refit the engine/transmission unit to the car as detailed in Section Aa.3.

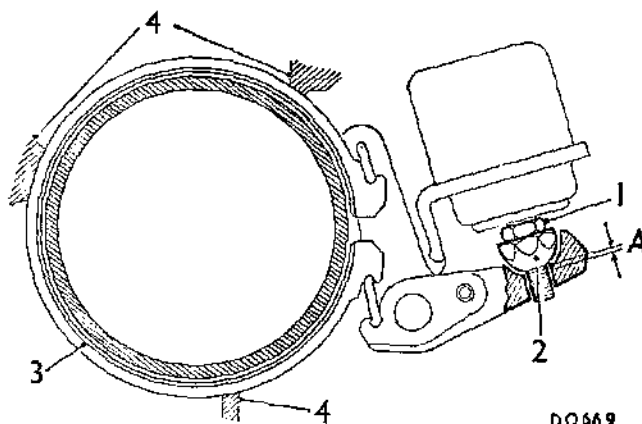

Fig. Fa.23

The servo unit band adjustment

A = .040 to .080 in. (1.02 to 2.03 mm.)

Section Fa.4

VALVE BLOCK

Early models

The valve block can be removed from the transmission unit with the power unit *in situ* by removing the unit as three individual sections.

It is necessary to clean thoroughly the area around the transmission front cover before any dismantling is commenced. Absolute cleanliness is essential at all times and especially so whilst servicing this unit.

Later 848-c.c. and 998-c.c. models

The valve block assembly cannot be removed from the transmission unit with the power unit *in situ* but the lid and valve chest can be removed for dismantling and cleaning. If it is necessary to examine and/or fit new seals to the valve block/servo unit interconnecting pipes or to remove the pipe chest, it is necessary to remove the power unit from the car and remove the converter and housing (see items (25) to (32)).

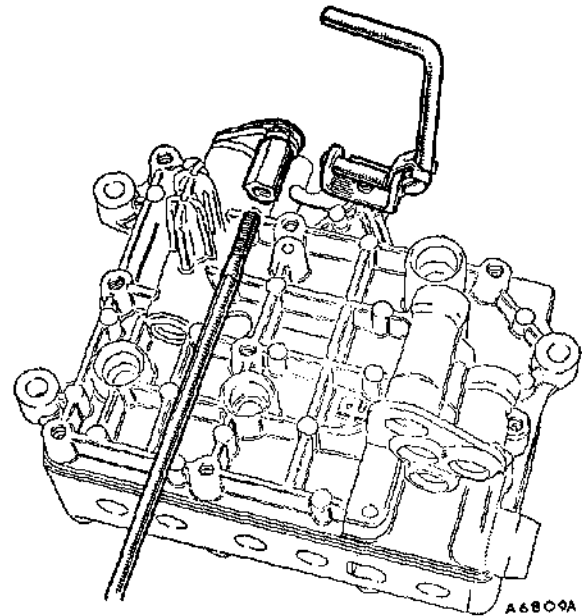

Fig. Fa.24

The gear selector rod and the governor valve linkage

Removing (early models)

- (1) Remove the front grille.
 - (2) Remove the filter assembly as detailed in Section Aa.2.
 - (3) Remove the engine oil feed pipe.
 - (4) Drain the engine/transmission unit.
 - (5) Remove the transmission front cover and valve block bobbin.
 - (6) Place the gear selector lever in the 'R' position on the quadrant.
 - (7) Remove the bell-crank lever clevis pin. Unscrew and pull out the selector rod sufficiently to remove the valve block.
 - (8) Loosen the servo unit securing bolts.
 - (9) Remove the valve block assembly as individual components, i.e. the lid, valve chest, and finally (if necessary) the pipe chest (Fig. Fa.25).
- The valve block can only be removed as an assembly with the power unit removed from the car.

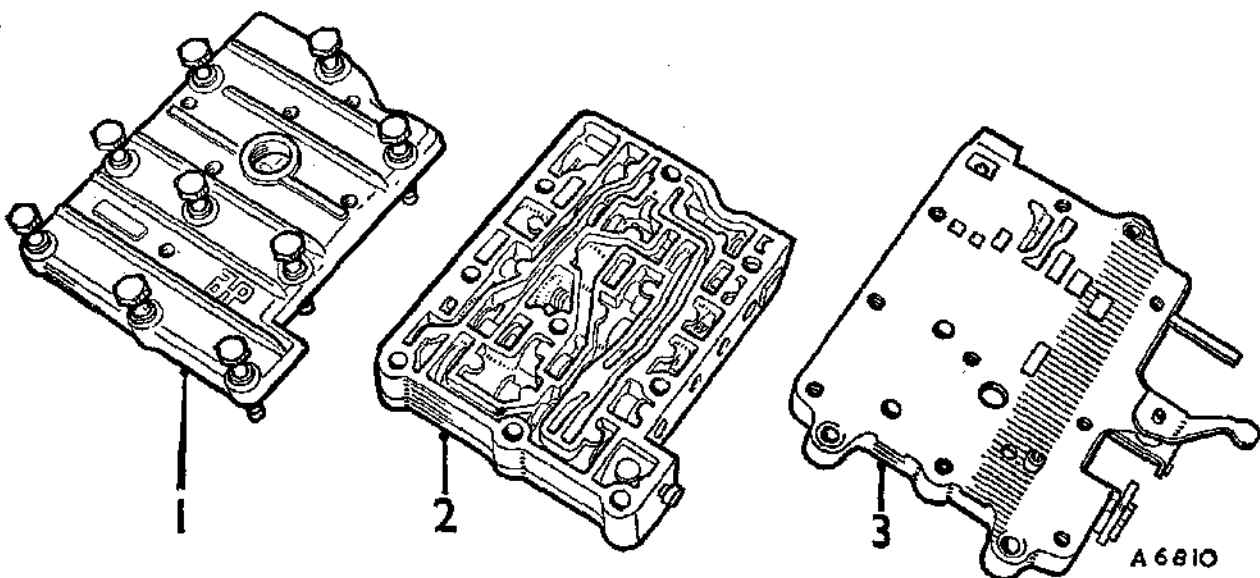

Fig. Fa.25

The valve block assembly

1. Lid.

2. Valve chest.

3. Pipe chest.

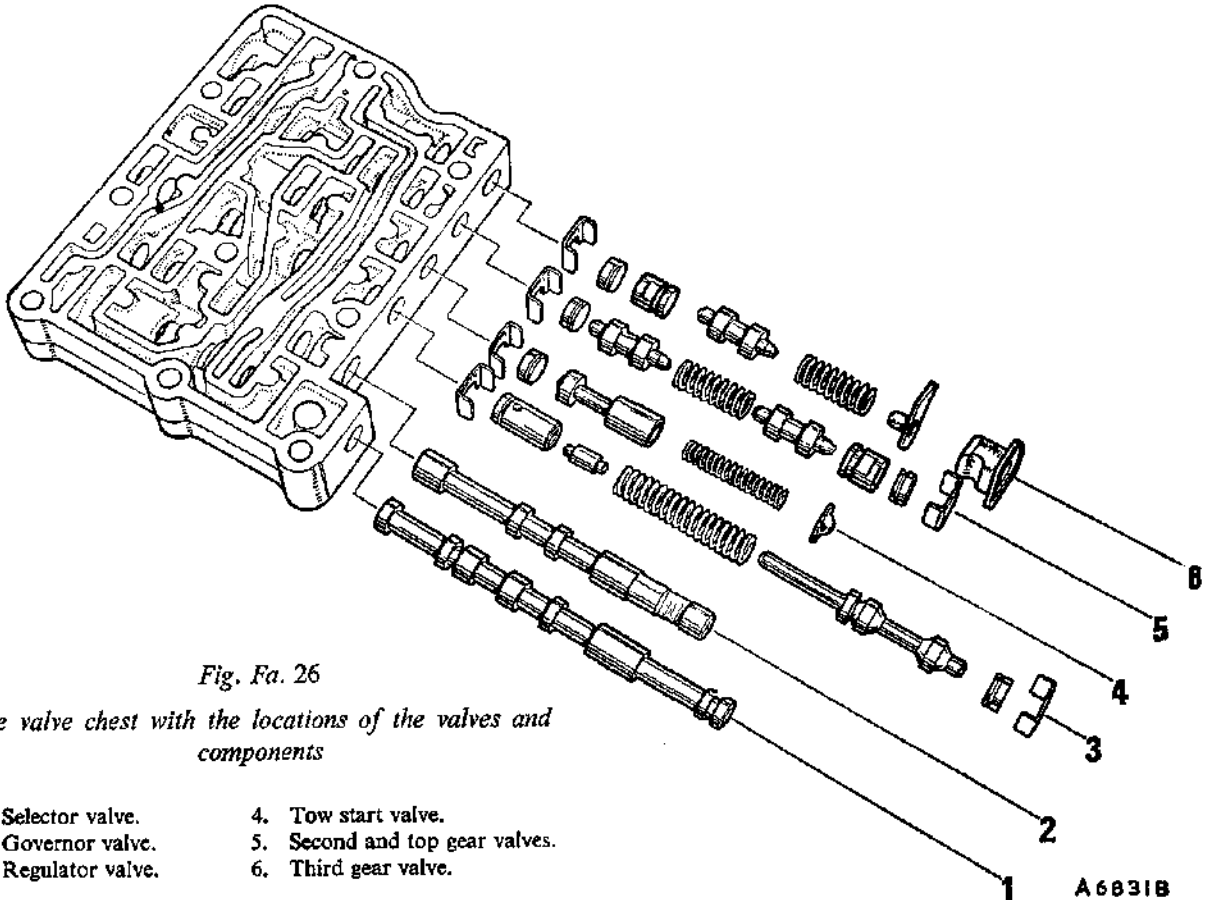

Fig. Fa. 26

The valve chest with the locations of the valves and components

- | | |
|---------------------|--------------------------------|
| 1. Selector valve. | 4. Tow start valve. |
| 2. Governor valve. | 5. Second and top gear valves. |
| 3. Regulator valve. | 6. Third gear valve. |

VALVE CHEST ONLY—'POWER UNIT IN SITU'

Removing (later 848-c.c. and 998-c.c. models)

- (10) Carry out items (1), (2), and (4).
- (11) Disconnect the engine oil feed pipe and remove the adaptor. Withdraw the valve block connecting pipe through the adaptor hole.
- (12) Remove the transmission front cover and manoeuvre the cover upwards and out through the grille aperture.
- (13) Remove the valve block lid and the valve chest.

NOTE.—Before dismantling the valve block it must be remembered that the valves are selected for each bore. It is of the utmost importance therefore to reassemble each valve into its original bore and position. Cleanliness is essential at all times.

Dismantling

- (14) Remove the lid and valve chest from the pipe chest (if removed as a unit, see Fig. Fa.25).
- (15) Remove the selector and governor valves.
- (16) Remove the 'C' clips and the plugs. Remove the regulator valve, spring, and reverse booster piston assembly.
- (17) Remove the 'C' clip and the plug. Remove the tow-start valve, spring, and spring retainer.

- (18) Remove the 'C' clips and the plugs. Remove the second and fourth gear valves, spring, and booster piston.
- (19) Remove the 'C' clip and tap out the plug. Remove the third gear valve booster piston, spring, spring retainer, and the plastic plug.

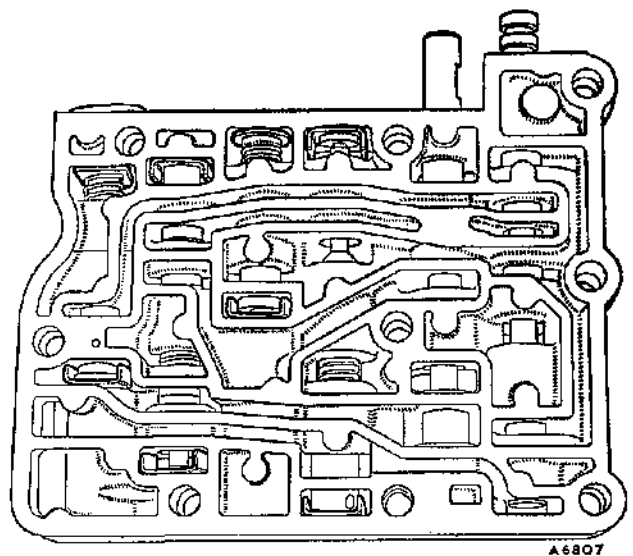

Fig. Fa.27

The valve chest with the 'C' clips correctly positioned

Inspecting

Clean all parts thoroughly in clean fuel (petrol) or paraffin (kerosene) and dry off using an air pressure line.

Check for burrs on the valves and valve chest and for sticking valves. Place all components in automatic transmission oil before reassembling to the valve block.

Reassembling

- (20) Reassemble each valve assembly in the reverse order of dismantling (see Fig. Fa.26). Check that the 'C' clips and plugs are correctly located in the valve chest (see Fig. Fa.27).

Refitting

- (21) Refitting is a reversal of the removal procedure; take care to locate the selector valve with the linkage and the governor rod with the governor. The flat on the governor valve must face inwards. Tighten all securing bolts to the torque figures given in 'GENERAL DATA'.

- (22) Ensure that the new joint washer fitted to the filter head/transmission front cover is correctly fitted.
 (23) Check and adjust if necessary the gear change cable and selector rod adjustment (see Section Fa.2).
 (24) Refill the engine/transmission unit with the recommended oil to the 'MAX' mark on the dipstick (see Section Aa.1).

VALVE BLOCK ASSEMBLY REPLACEMENT 'POWER UNIT REMOVED'

Removing (later 848-c.c. and 998-c.c. models)

- (25) Remove the engine/transmission unit from the car (Section Aa.3).
 (26) Remove the converter cover, converter and converter housing as detailed in Section Aa.4, items (3) to (11).
 (27) Carry out items (10) and (11) and remove the front cover.
 (28) Remove all the servo unit securing bolts.
 (29) Remove the bell-crank lever clevis pin. Unscrew and pull out the selector rod.
 (30) Carry out operations (2) and (3) in Section Fa.5.

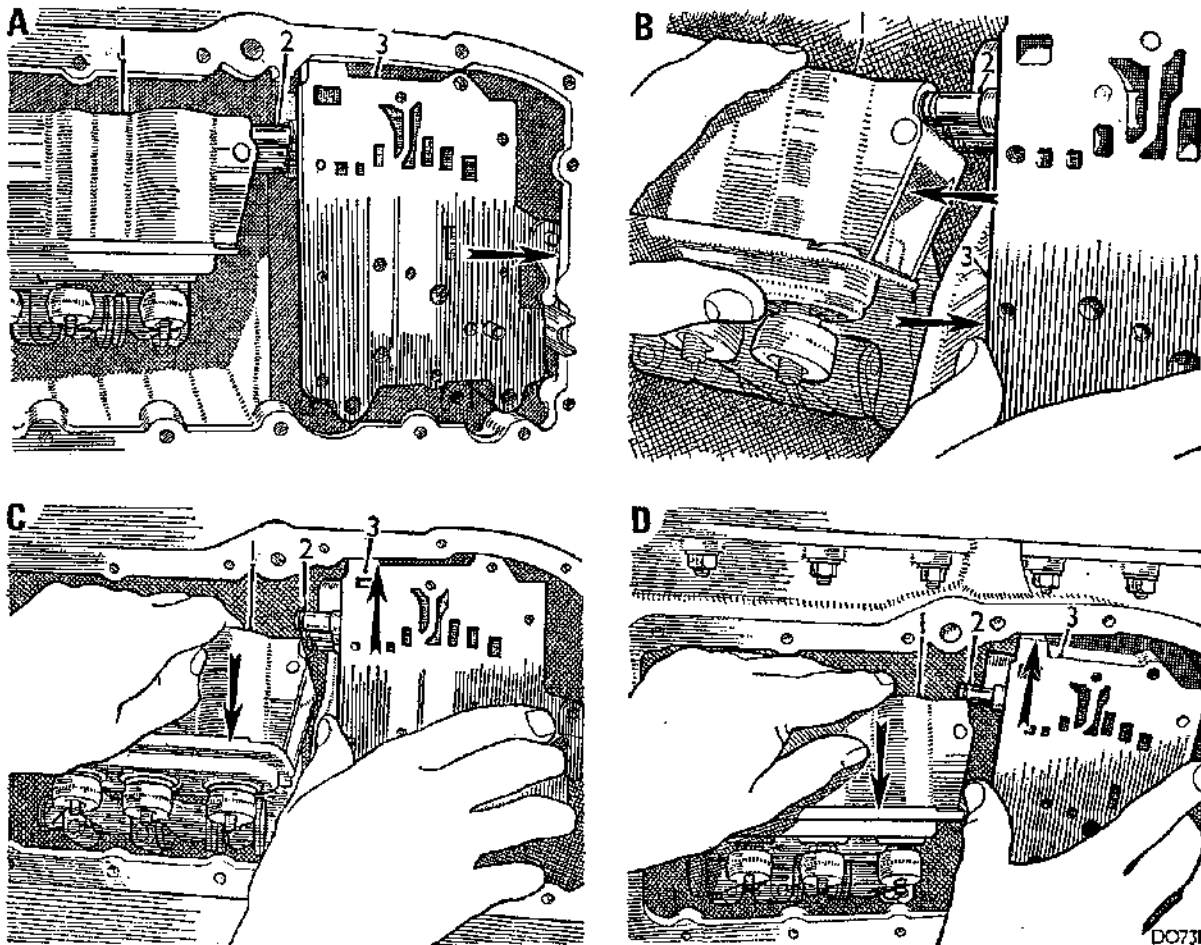

Fig. Fa.28

The removing and refitting sequence of the pipe chest section of the valve block

1. Servo unit. 2. Connecting pipes. 3. Pipe chest.

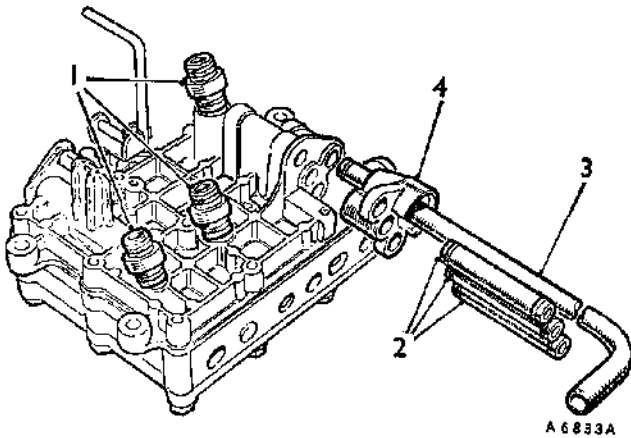

Fig. Fa.29

The valve block assembly showing

1. Three connecting bobbins.
2. Valve block to servo pipes.
3. Valve block to converter feed pipe.
4. Pipe assembly guide.

- (31) Remove the valve block lid and valve chest.
- (32) Remove the pipe chest as shown in the operation sequence in Fig. Fa.28 after pulling it outwards to release it from the bobbins and to disconnect the governor linkage.
- (33) Refer to Fig. Fa.28.
 - (a) Push the pipe chest fully against the casing.
 - (b) Move the servo unit in the opposite direction until the three pipes are clear of the servo unit.
 - (c) Pull the servo unit outwards and downwards; lift the pipe chest upwards and (when clear), move it so that the pipes are over the top of the servo and the regulator valve lever is clear of the transmission casing.
 - (d) Hold the servo unit down and withdraw the pipe chest after lifting the linkage over the web in the casing.

Fitting replacement unit

- (34) Remove the lid and valve chest from the pipe chest of the new unit. Refit these as individual components in the reverse order of the removing procedure, noting the following points:
- (35) Fit the three bobbins into their locations in the transmission case.
- (36) Assemble the three pipes into the pipe chest (together with the nylon guide) before refitting the unit to the transmission casing.
- (37) Carry out operation (21).
- (38) Position the plastic sleeve over the rings on the forward clutch shaft.
- (39) Carry out operations (36) to (38) in Section Fa.3.
- (40) The remainder is a reversal of the removal procedure.

Section Fa.5

AUXILIARY PUMP AND GOVERNOR

Removing

- (1) Remove the engine/transmission unit from the car as detailed in Section Aa.3.

- (2) Remove the governor control assembly from the transmission case and fit Service tool 18G 1097 (see Fig. Fa.19).
- (3) Remove the securing nuts and pull the auxiliary pump and governor assembly from the transmission case.

Dismantling

- (4) Remove the speedometer drive assembly.
- (5) Remove the set screws and bolt. Pull out the governor centre shaft, and lift away the governor assembly together with one of the auxiliary pump gears.
- (6) Remove the circlip, lift off the auxiliary pump gear, and remove the governor.
- (7) Lift out the governor bearing trunnions and washer.
- (8) Remove the second auxiliary pump gear from the auxiliary pump casing together with its bi-metal washer.

Reassembling

- (9) Reassemble the auxiliary pump gear with its bi-metal washer to the pump casing.
- (10) Refit the governor auxiliary pump gear and circlip. Ensure that both gears are seating correctly and will rotate freely after assembly.
- (11) Refit the governor assembly to the auxiliary pump and refit the centre shaft.
- (12) Use Service tool 18G 1106 to centralize the auxiliary pump and governor unit with the end cover, tighten the securing bolts to the torque figure given in 'GENERAL DATA' and remove the Service tool.
- (13) Refit the speedometer drive assembly, with a new joint washer.

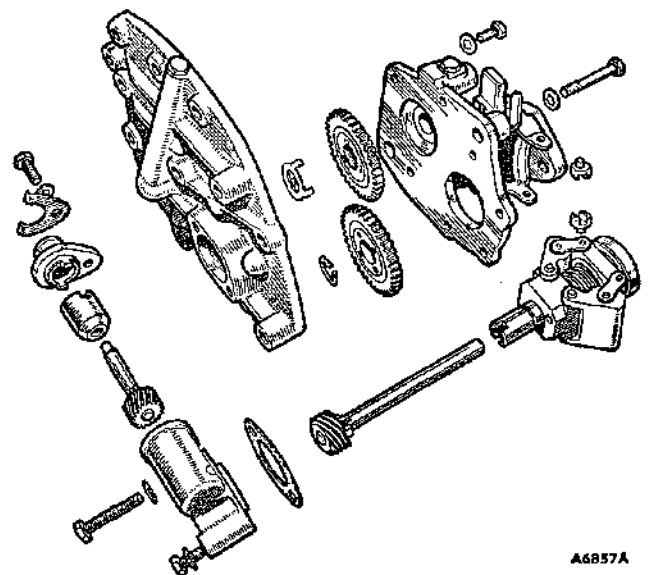

Fig. Fa.30

The speedometer drive and governor assembly components

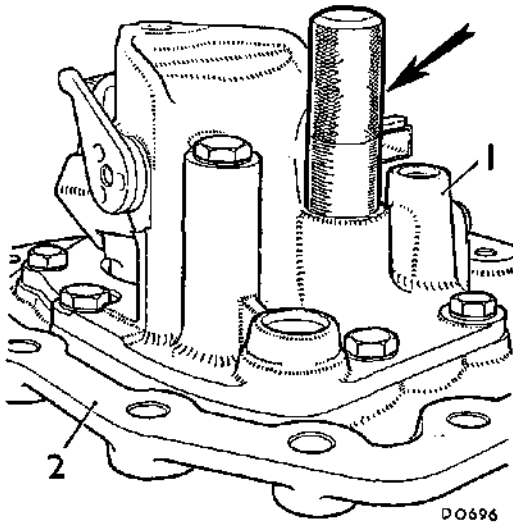

Fig. Fa.31

Centralizing the pump and governor unit (1) with the end cover (2) using Service tool 18G 1106 (arrowed)

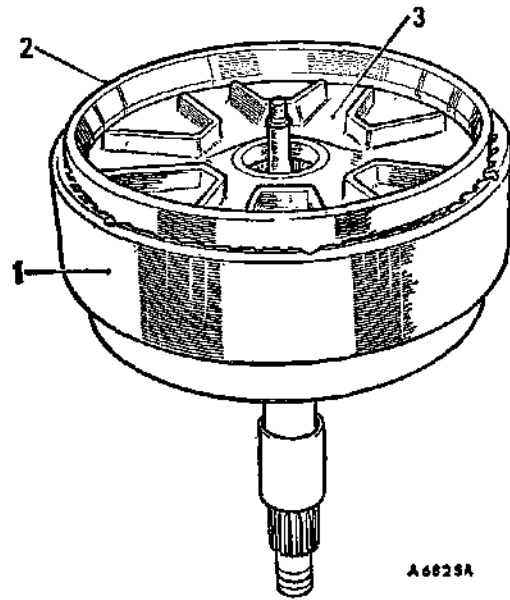

Fig. Fa.32

Fitting the forward clutch piston using Service tool 18G 1102

1. Forward clutch.
2. Service tool 18G 1102.
3. Forward clutch piston.

Refitting

- (14) Carry out the instructions given in Section Fa.3, items (36) and (38).

NOTE. — See 'GENERAL DATA' for all torque figures.

Section Fa.6

FORWARD CLUTCH

Two types of clutch assembly are in use; the earlier type having 47 teeth is shown in Fig. Fa.34. This unit is now replaced by the 30-tooth clutch as shown in Fig. Fa.35. The two clutch assemblies are not interchangeable; when a replacement unit is required only the identical unit to that removed must be fitted.

Removing

- (1) Carry out the operations given in Section Fa.3, items (1), and (5) to (9).

Dismantling

- (2) Remove the circlip.

NOTE.—Mark the retainer plate and steel clutch plate to assist when reassembling.

- (3) Remove the retainer plate and clutch plates (two paper, one steel).
- (4) Lift out the piston return springs and pressure plate.
- (5) Remove the spring ring (if fitted) and toggles (see Fig. Fa.34).
- (6) Use an air pressure line to blow out the piston.
- (7) Remove the circlip and lift out the reverse shut-off valve.

Inspecting

Check all parts for wear and renew if necessary. Check the reverse shut-off valve oil seals and renew if necessary.

Reassembling

- (8) Refit the reverse shut-off valve and fit a new circlip.

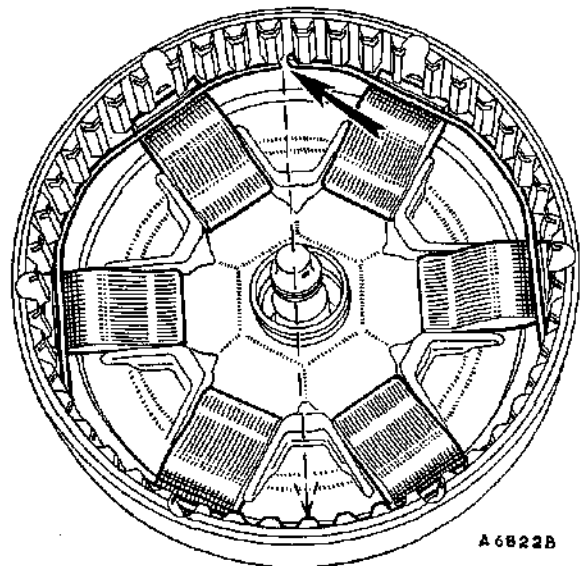
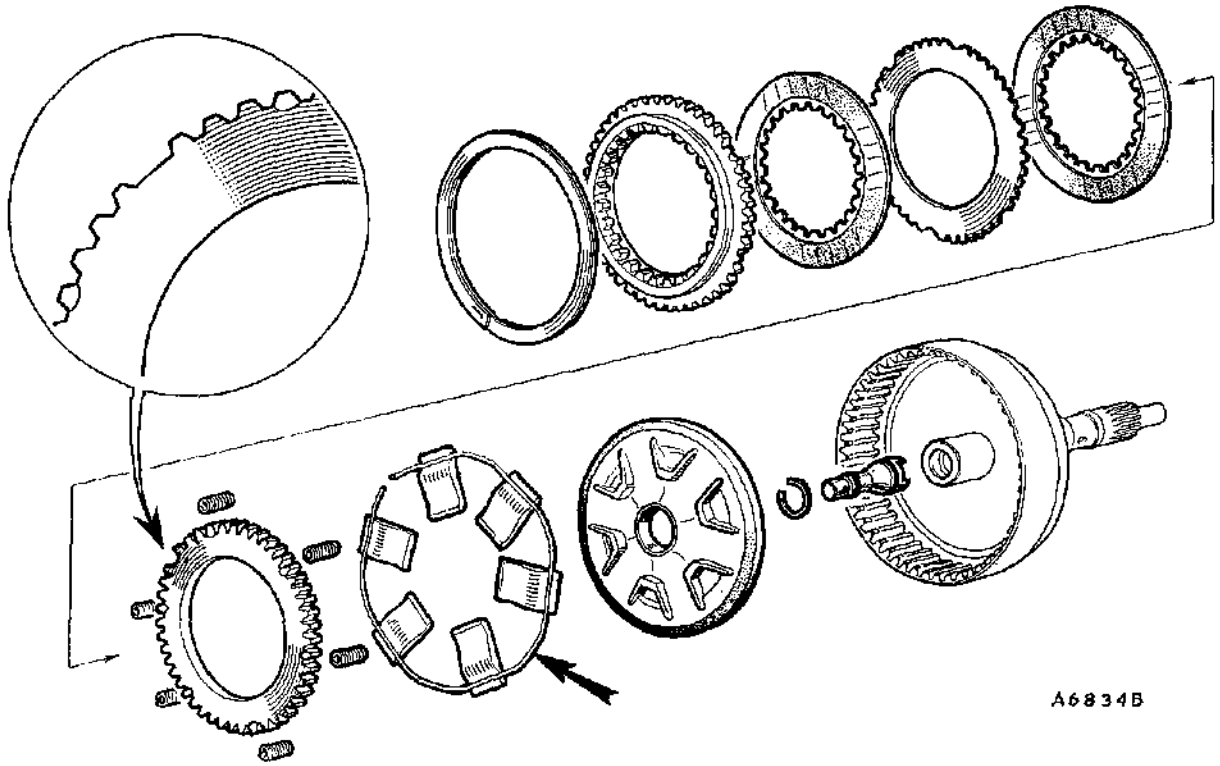

Fig. Fa.33

The fitted position of the toggles and spring ring (fitted to very early units). The arrow indicates location of spring ends exactly opposite the only five tooth section of the clutch unit



A6834B

Fig. Fa.34

The early-type (47-tooth) forward clutch components. The arrow indicates the spring ring fitted to very early units only

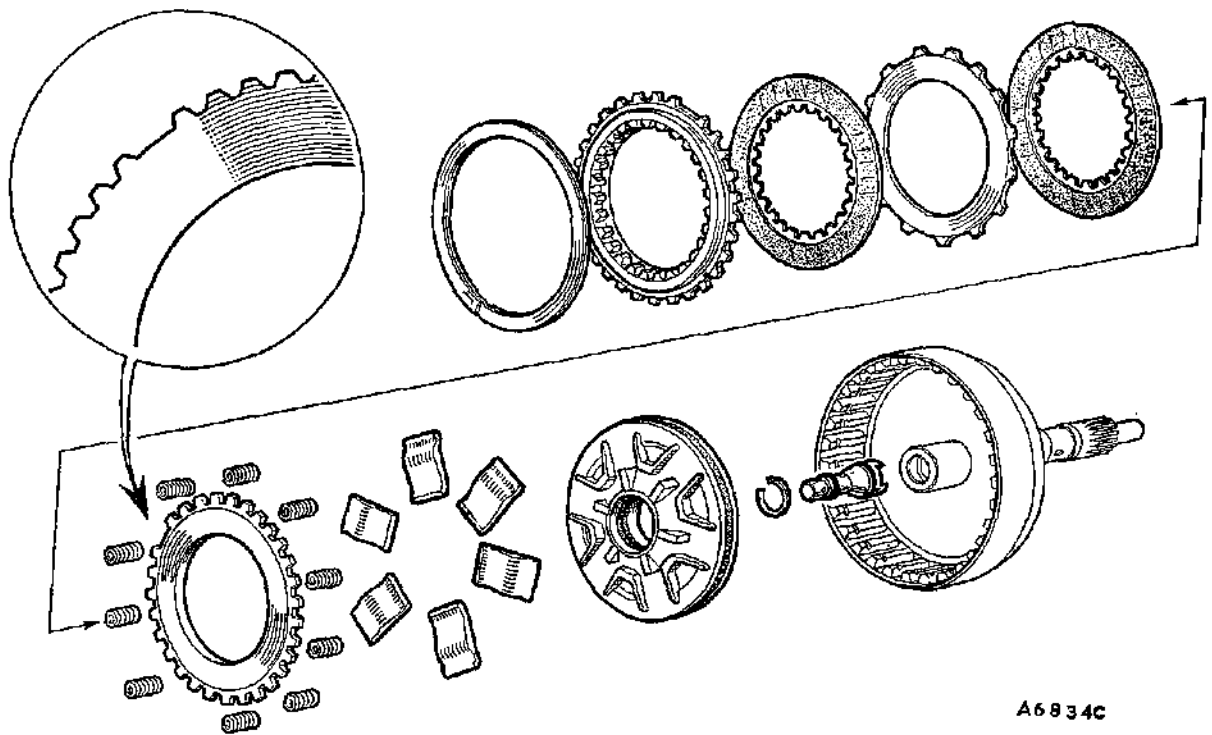

A6834C

Fig. Fa.35

The (30-tooth) forward clutch components

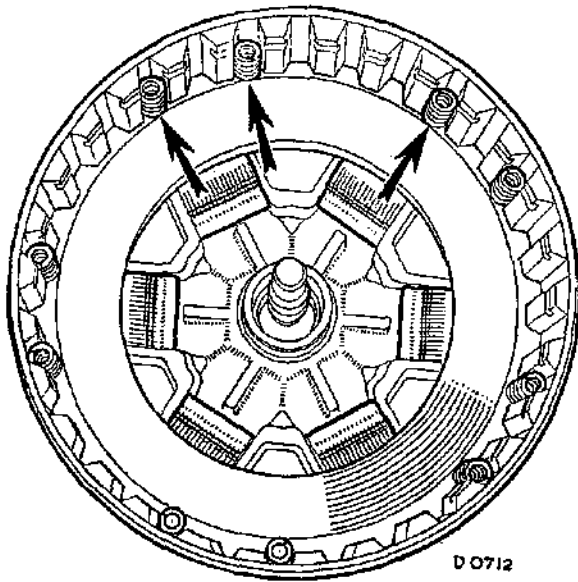

Fig. Fa.36

The fitted position of the toggles and springs of the 30-tooth clutch

- (9) Using Service tool 18G 1102, assemble the piston with the lips of the seal facing inwards and lubricated with transmission oil.
- (10) 47-tooth clutch. Assemble the toggles and spring ring (early units) with the ends of the spring ring located as shown in Fig. Fa.33, and with the cut-out tooth on the pressure plate in the relative position to the ends of the spring ring (Fig. Fa.34). Assemble the clutch plates and the piston return springs.
- (11) 30-tooth clutch. Assemble the toggles, pressure plate, and the piston return springs as shown in Fig. Fa.36. Refit the clutch plates and the retainer plate (see Fig. Fa.35).

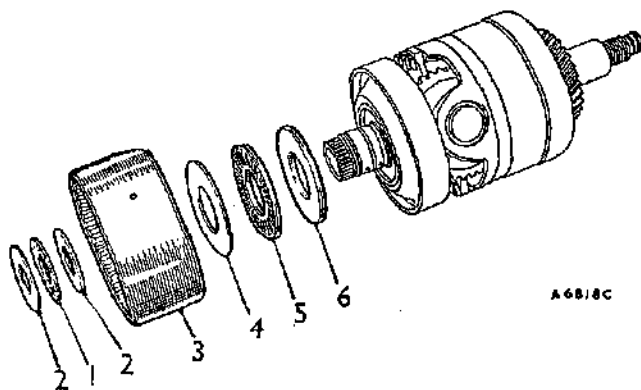

Fig. Fa.37

Removing the top and reverse clutch

- | | |
|--------------------------------------|--------------------------------------|
| 1. Torrington needle thrust bearing. | 4. Thrust washer. |
| 2. Thrust washers. | 5. Torrington needle thrust bearing. |
| 3. Top and reverse clutch. | 6. Selective washer. |

Fa.30

- (12) Refit the retainer plate with its six recessed teeth positioned relative to the piston return springs.
- (13) Refit the circlip.

Refitting

- (14) Carry out the operations given in Section Fa.3 items (28) and (34) to (38).
- (15) Refit the governor linkage.

Section Fa.7

GEAR TRAIN

The gear train is accurately assembled with special equipment to obtain the correct backlash on the various gears and it is not possible to assemble this unit to factory standard without this special equipment. In the event of failure of any part of this unit a new complete gear train assembly must be fitted. The only washer in the gear train which can be renewed is the forward output gear bi-metal washer (8) (see Fig. Fa.42); this is not a selective size washer.

Removing

- (1) Carry out the operations given in Section Fa.3, items (1) to (2b) and (12).

Dismantling

- (2) Remove the top and reverse clutch.

NOTE.—For top and reverse clutch dismantling and reassembling see Section Fa.10.

- (3) Remove the thrust race and washers (Fig. Fa.37).

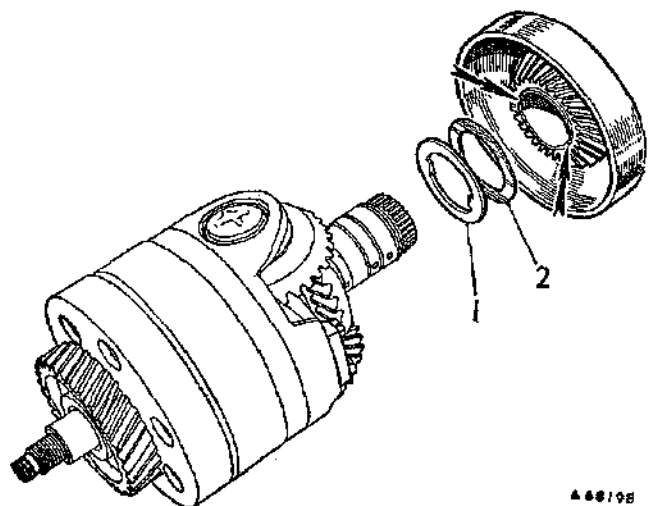

Fig. Fa.38

Removing the third speed reaction gear. The arrows indicate the bi-metal washer locations

- | | |
|---------------------|----------------------|
| 1. Bi-metal washer. | 2. Shim (if fitted). |
|---------------------|----------------------|

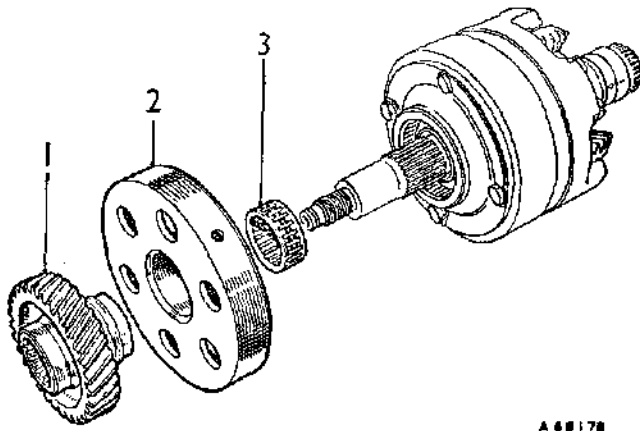

Fig. Fa.39

Removing the input gear (1), the first gear free-wheel reaction member (2), and the needle-roller bearing (3)

- (4) Remove the third gear reaction member together with its thrust washer and shim (if fitted) (Fig. Fa.38).
- (5) Remove the input gear, and pull off the first gear free-wheel reaction member and needle-roller bearing (Fig. Fa.39).
- (6) Knock back the lock washers and remove the first gear free-wheel housing set screws.
- (7) Pull out the first gear free-wheel assembly, input gear, Torrington thrust race, and washer (Fig. Fa.40).

NOTE.—For first gear free-wheel assembly dismantling and reassembling see Section Fa.11.

Dismantling of the gear train is necessary only if the forward output gear bi-metal washer is to be replaced.

- (8) To dismantle the early-type gear train assembly as shown in Fig. Fa.42, refer to items (16) to (19), with the reassembly sequence given in items (33) to (36).

Dismantling of the later gear train assembly is given below in items (9) to (15), with the reassembly sequence in items (20) to (32).

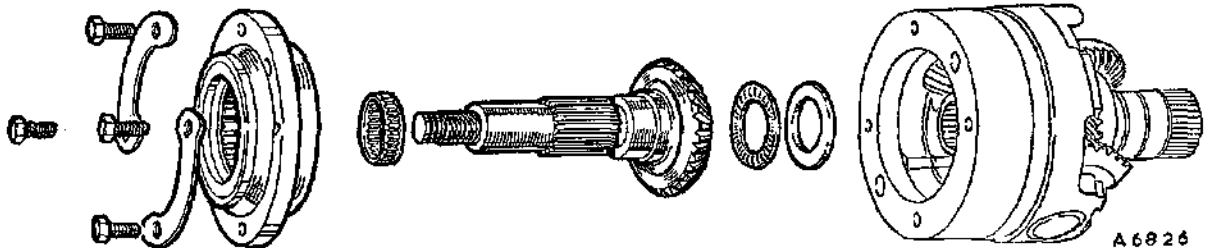

Fig. Fa.40

Removing the one-way clutch and the input gear with its Torrington needle thrust bearing and washer

Dismantling gear train (later-type)

- (9) Remove the spindle end cover circlips and covers; remove the small locking circlip and unscrew the spindle locking screws.
- (10) Hold the unit on its side until the locking ball rolls out from the hole in the planetary gear spindle. Repeat this operation on the other side.
- (11) Insert Service tool 18G 1093 A into the forward output gear and through the complete assembly to assist the dismantling procedure.
- (12) Screw the Service tool adaptor 18G 284 AJ into one of the planetary gear spindles and using Service tool 18G 284 pull the spindle from the gear. Repeat this operation with the other spindle and withdraw the needle-roller bearings.
- (13) Knock back the locking tabs and remove the strap securing bolts.
- (14) Ease the strap off the dowels and lift the complete assembly from the carrier.
Retain the respective positions of each planetary gear thrust washer with the carrier.
- (15) Dismantle the assembly, ensuring that all components are retained in their respective positions for reassembly (see Fig. Fa.43).

Dismantling gear train (early-type)

- (16) Check the markings on the carrier and the bearing caps, i.e. marked NIL or with the letter 'O'. These are reference marks to fitting dimensions and the caps must be refitted in their original positions as indicated by the markings on reassembly of the unit.
- (17) Knock back the locking tabs and remove the bearing cap bolts and the strap securing bolts. Lift out the forward output gear, reverse output gear, and the pinions.
- (18) Lift off the thrust bearings, pinions, and thrust washers.
- (19) Lift off the forward output gear and thrust washer, the reverse output gear, thrust washer, and thrust race.

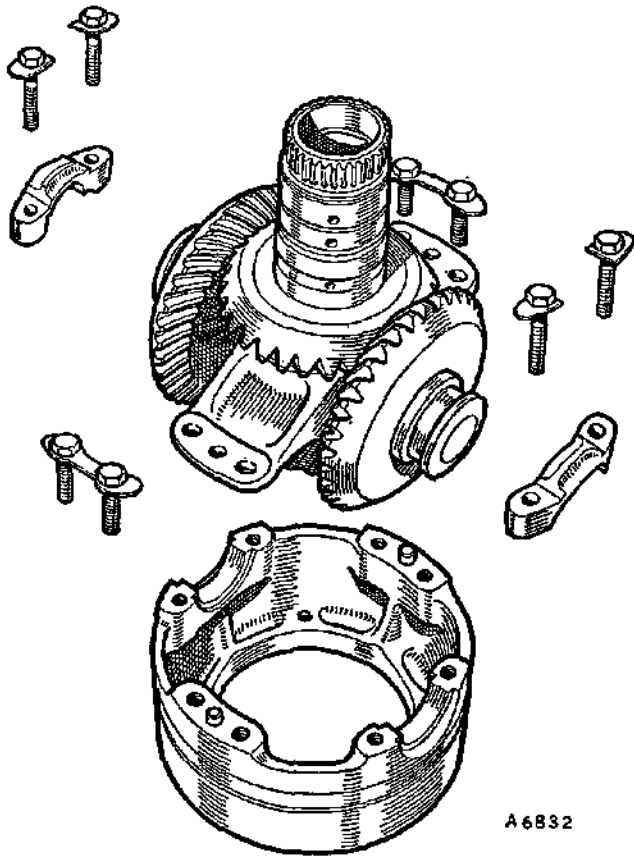

Fig. Fa.41

Removing the forward and reverse output gears, and the planetary gears from the carrier

Inspecting

Clean and examine all parts for wear. Fit a new bi-metal washer to the forward output gear if required and renew if necessary the Torrington needle-thrust races.

Fit new rubber seals and replace the locking plates.

NOTE.—Use petroleum jelly when reassembling to secure the various thrust washers and needle thrust races in position.

Reassembling gear train (later-type)

(20) Assemble the forward output gear with its bi-metal washer and the .004 in. (.10 mm.) shim (if fitted) interposed between the bi-metal washer and the carrier (see Fig. Fa.44).

Assemble the reverse output gear with its Torrington needle thrust bearing and steel washer.

(21) Insert Service tool 18G 1093 A through the forward output gear and the assembly to ensure correct alignment.

(22) Check and reset the timing of the gear train (see Fig. Fa.45) by rotating the planetary gears until the timing marks are in alignment.

(23) Retain the timed position of the gear train and refit to the carrier ensuring that both timing marks align with the dowel surface of the carrier.

(24) Refit the planetary gear needle-roller bearings and tap in the spindles (with the hole on the centre of the spindle facing downwards).

(25) Insert a ball into each spindle and screw in the locking screws. Refit the locking screw circlips, end covers, and the cover circlips.

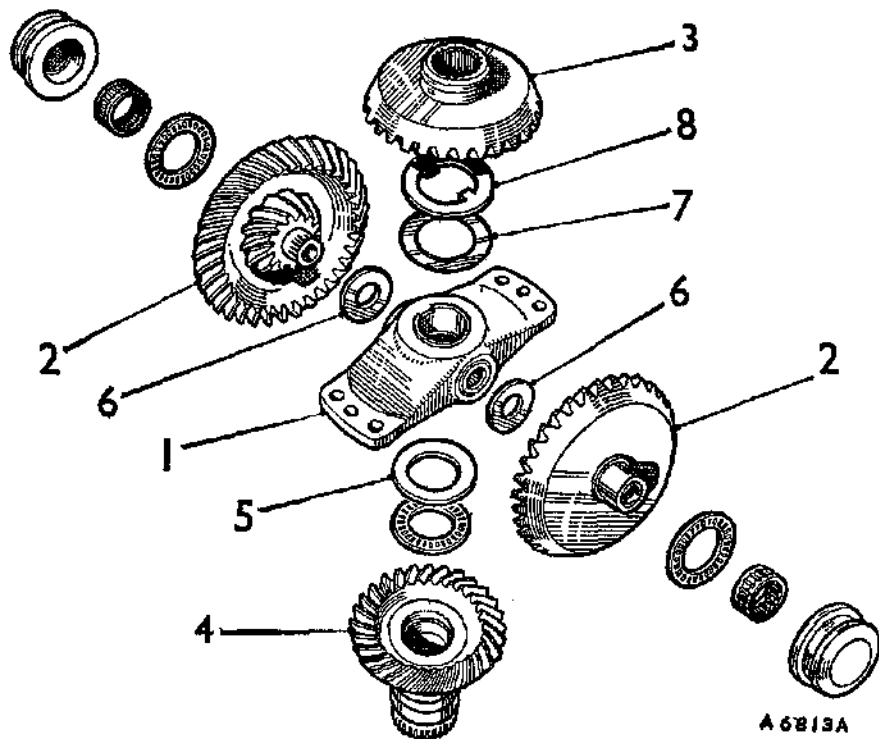

Fig. Fa.42

The early-type gear train completely dismantled

1. Gear carrier.
2. Planetary gears.
3. Forward output gear.
4. Reverse output gear.
5. Steel washer (reverse output gear).
6. Planetary gear washers.
7. Steel shim (forward output gear).
8. Bi-metal washer (forward output gear).

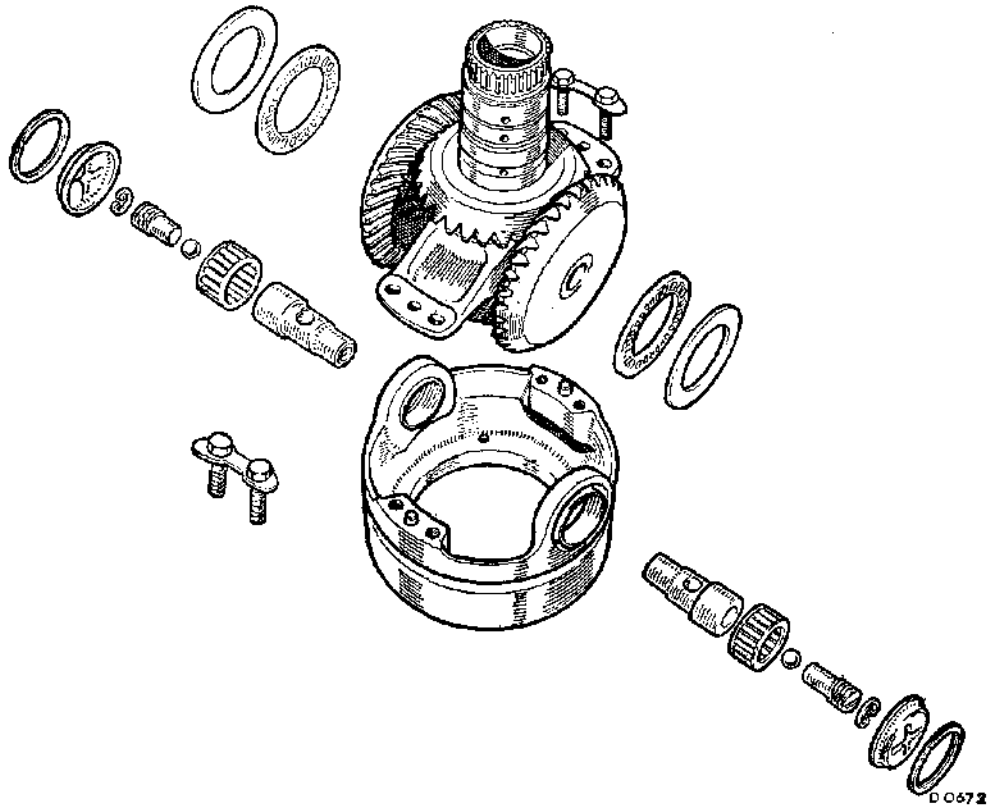

Fig. Fa.43

The later-type gear train, with the forward and reverse output gears and the planetary gears removed from the carrier

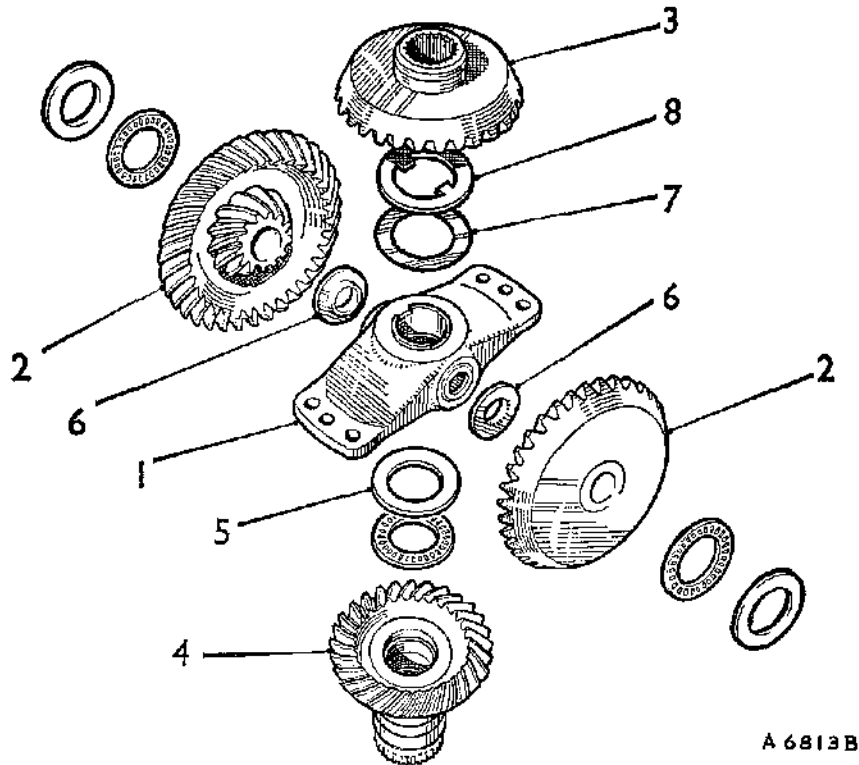

Fig. Fa.44

A dismantled view of the later-type gear train assembly

- | | |
|-------------------------|---|
| 1. Gear carrier. | 5. Steel washer (reverse output gear). |
| 2. Planetary gears. | 6. Planetary gear washers. |
| 3. Forward output gear. | 7. Steel shim (forward output gear). |
| 4. Reverse output gear. | 8. Bi-metal washer (forward output gear). |

(26) Assemble the third speed reaction gear with its bi-metal washer fitted with the white metal face towards the reverse output gear (see Fig. Fa.46) and with the steel shim(s) located between the bi-metal washer and the gear.

Retain each washer and shim in position with petroleum jelly and refit the assembly to the gear train (see Fig. Fa.46).

(27) Assemble the bevel input shaft with its Torrington needle thrust bearing and selective steel washer (see Fig. Fa.40).

(28) Refit the one-way clutch to the gear train housing (Fig. Fa.40), tighten the securing bolts, and tap up the locking plate tabs.

(29) Refit the free-wheel support.

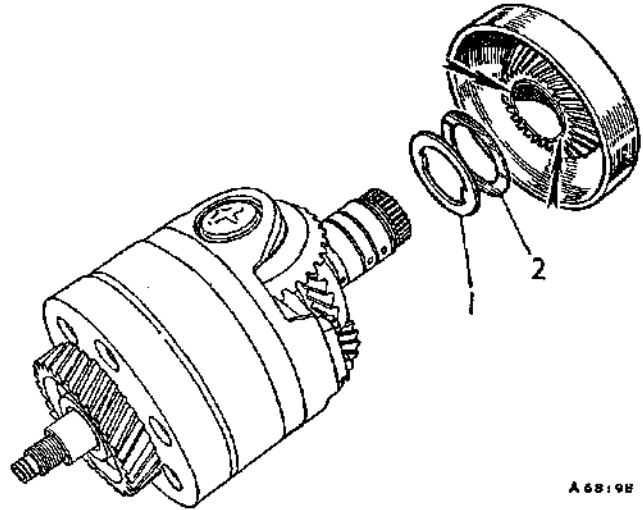

Fig. Fa.46

Refitting the third speed reaction gear with its bi-metal washer, locations indicated by arrows

1. Bi-metal washer. 2. Shim (if fitted).

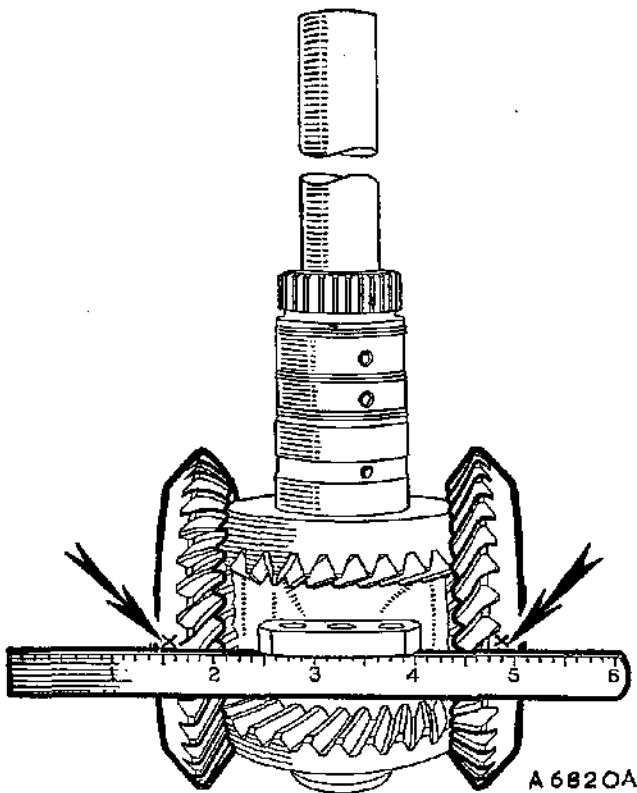

Fig. Fa.45

Timing the gear train

(30) Refit the input gear and needle-roller bearing (see Fig. Fa.47).

(31) Refit the top and reverse clutch with its selective steel washer and Torrington needle thrust bearing onto the reverse output shaft (see Fig. Fa.48).

(32) Check across the splined end of the reverse output shaft and the adjacent face of the top and reverse clutch (Fig. Fa.49). Both faces must be exactly level with no gap, to ensure that the third speed reaction gear has no end-float and the correct backlash is maintained. If both faces are not level, remove and measure the thickness of the selective steel washer fitted in item (31) and fit the correct selective washer from the range available (see washer chart below).

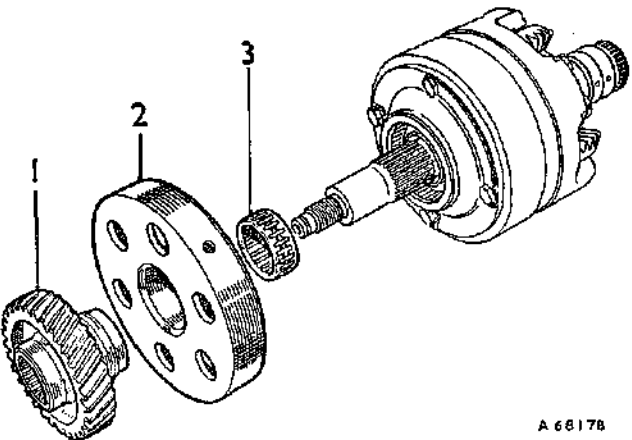

Fig. Fa.47

Refitting the input gear (1), the first gear free-wheel reaction member (2), and the needle-roller bearing (3)

| Selective Washer Sizes | Part Nos. |
|-------------------------------------|-----------|
| ·076 to ·078 in. (1·93 to 1·98 mm.) | 22G 748 |
| ·072 to ·074 in. (1·83 to 1·88 mm.) | 22G 749 |
| ·068 to ·070 in. (1·73 to 1·78 mm.) | 22G 750 |
| ·064 to ·066 in. (1·63 to 1·68 mm.) | 22G 751 |

Reassembling gear train (early-type)

(33) Carry out items (20) to (23) with the following exceptions: Refer to Fig. Fa.42, and use Service tool 18G 1093 when reassembling this early-type gear train.

(34) Refit the bearings caps to their respective positions (see markings) and using new locking plates, refit and tighten the bearing cap and carrier bolts to the torque figure given in 'GENERAL DATA'.

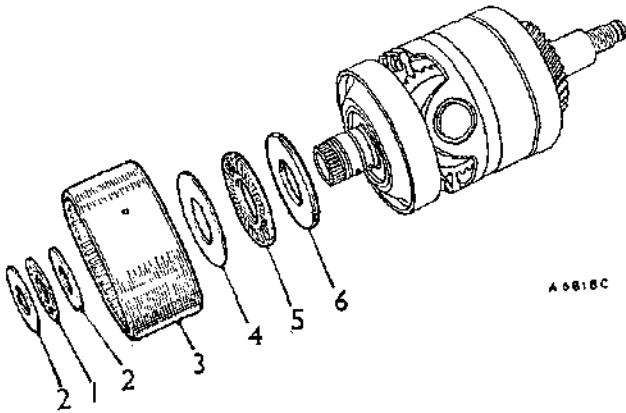

Fig. Fa.48

Refitting the top and reverse clutch

- | | |
|--------------------------------------|--------------------------------------|
| 1. Torrington needle thrust bearing. | 4. Thrust washer. |
| 2. Thrust washers. | 5. Torrington needle thrust bearing. |
| 3. Top and reverse clutch. | 6. Selective washer. |

(35) Carry out items (26) to (31).

(36) Carry out item (32) and note the 'example' and selective washer chart below.

The selective washers for the early units are not interchangeable with those fitted to later units.

Example: If the selective washer fitted in operation (23) was .0365 in. (.93 mm.) thick and after checking there was a gap, fit the correct selective washer from the range available (see washer chart below).

| Gap | Washer required |
|-------------------------------------|----------------------|
| .000 to .0035 in. (.000 to .08 mm.) | .1185 in. (3 mm.) |
| .0035 to .0075 in. (.08 to .19 mm.) | .1135 in. (2.88 mm.) |
| .0075 to .0115 in. (.19 to .29 mm.) | .1095 in. (2.78 mm.) |
| .0115 to .0150 in. (.29 to .38 mm.) | .1055 in. (2.67 mm.) |

Refitting

(37) Carry out the operations given in Section Fa.3, items (40) and (41). The remainder is a reversal of the removal procedure.

(38) Refit the power unit to the car as detailed in Section Aa.3.

Section Fa.8

SERVO ASSEMBLY

Removing

(1) Carry out the operations given in Section Fa.3 items (1) to (13).

(2) Remove the servo unit from the valve block assembly.

Dismantling

(3) Remove the centre shaft and lift out the servo levers, reaction levers, washers, and struts.

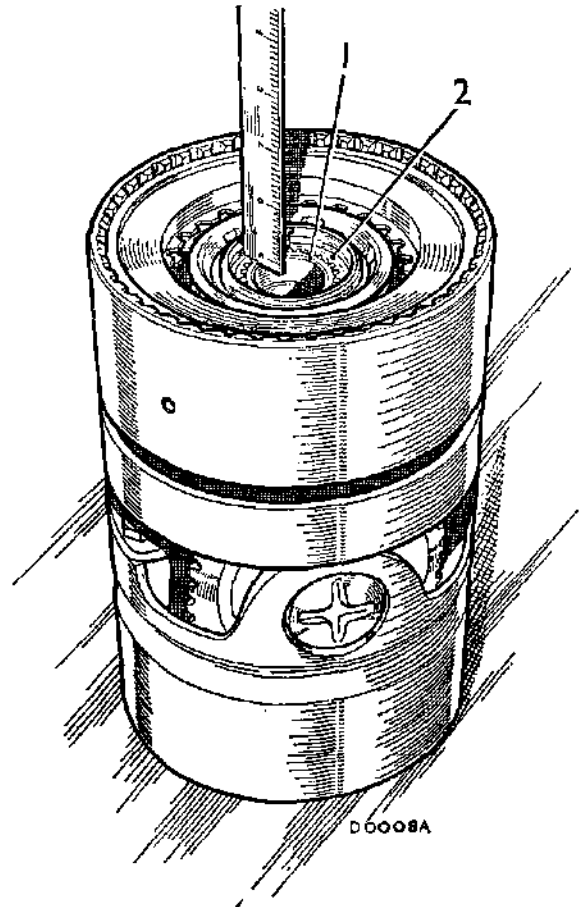

Fig. Fa.49

Checking that the end of the reverse output shaft (1) is level with the internal face of the top and reverse clutch (2)

(4) Hold the servo cover and release the securing screws and the cover.

(5) Lift out the springs and pistons.

Inspecting

Check all parts for wear and renew if necessary.

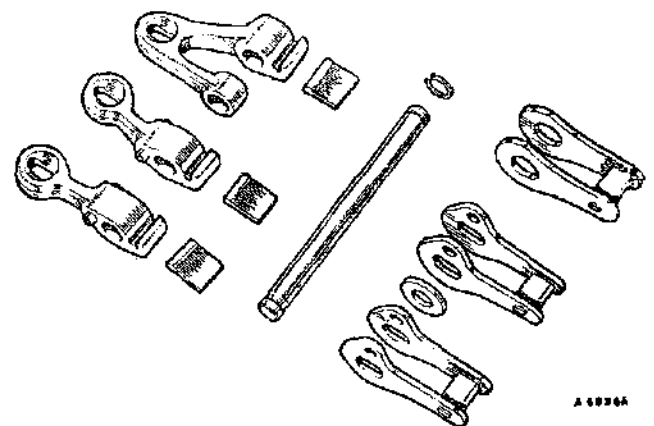
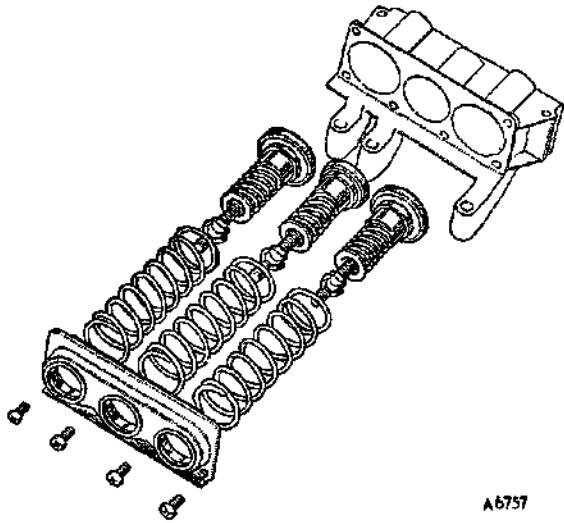

Fig. Fa.50

The fitting relationship of the servo levers with the reaction levers and struts



A6757

Fig. Fa.51

The servo unit components

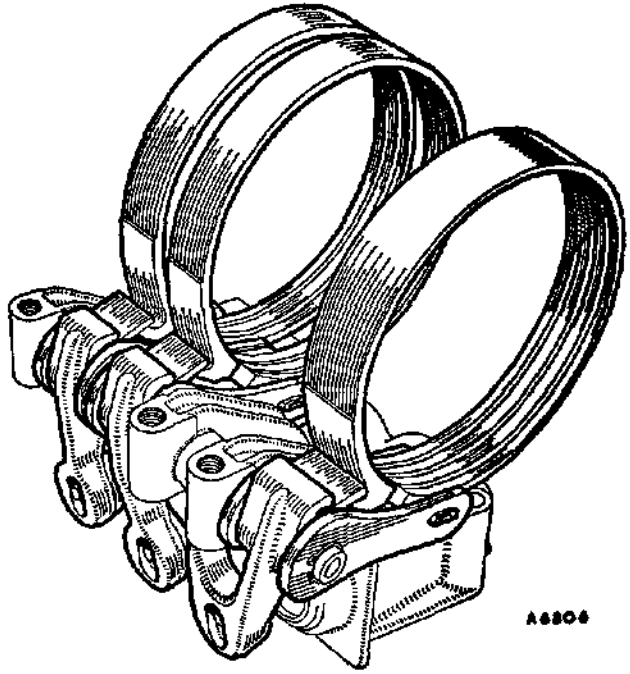

A6804

Fig. Fa.53

The brake band and struts correctly positioned

Reassembling

- (6) Lubricate the seals and fit the pistons into the correct bores (lips of seals facing downwards).
- (7) Assemble the springs and cover.
- (8) Hold the cover in position and fit the drive screws.
- (9) Assemble the struts, washer(s), reaction levers, and servo levers in the reverse order of dismantling (Figs. Fa.50, 52 and 53).
- (10) Insert the centre shaft with the cutaway in the shaft correctly positioned.

Refitting

- (11) Carry out the operations detailed in Section Fa.3, items (30) to (44), (48), and (49).

Section Fa.9

DIFFERENTIAL ASSEMBLY

Removing

- (1) Remove the engine and transmission from the car (see Section Aa.3).
- (2) Drain the engine/transmission unit.
- (3) Use Service tool 18G 1100 to hold the driving flanges and remove the centre securing bolts. Withdraw the flanges from the splined shafts.
- (4) Knock back the lock washers and remove the nuts from the final drive housing.
- (5) Remove the securing screws and pull the kick-down linkage assembly clear of the transmission case.
- (6) Remove the two set screws securing the end cover to the transmission, and remove the final drive and housing assembly (Fig. Fa.12).
- (7) Remove the remaining securing bolts from the end cover and remove the cover and the adjustment shims.

Dismantling

- (8) Remove the differential unit from its casing.
- (9) Withdraw the oil seal housing, remove the bearings using Service tool 18G 2.

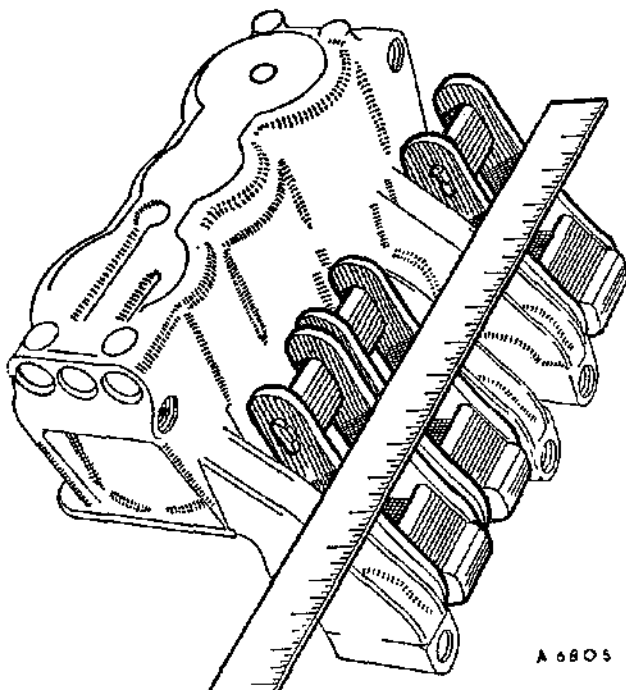

A6805

Fig. Fa.52

The correct fitted position of the servo reaction levers

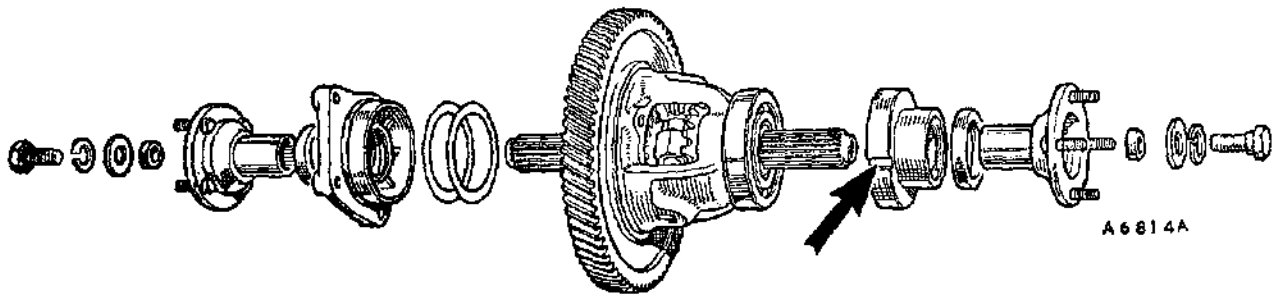

Fig. Fa.54

The differential components with the arrow indicating the alignment slot in the spacer

- (10) Knock back the locking plate tabs and remove the bolts securing the driving gear to the cage. Mark the gear and cage so that they can be refitted in their original positions.
- (11) Separate the driving gear from the cage and remove the differential gear and thrust washer from the driving gear.
- (12) Tap out the roll pin and remove both pinions and thrust washers, pinion spacer, and the other differential gear and thrust washer.

Inspection

Clean and examine the components for wear and fit new parts as necessary.

NOTE.—If any component has suffered damage with the result that swarf has been introduced into the lubricating system the automatic transmission must be removed (Section Aa.4) and dismantled as detailed in Section Fa.3.

This also applies if fitting a replacement drive gear pinion into the transmission unit.

Absolute cleanliness is essential.

Reassembling

- (13) Reassembly is a reversal of the dismantling procedure. Make sure that the differential gear thrust washers are refitted with their chamfered bores against the machined faces of the differential gears. Refit all components in their original positions.

Refitting

- (14) Refit the differential unit into the transmission case and push the assembly towards the converter, with the slot in the spacer in alignment with the dowel in the transmission case (Fig. Fa.54). Fit a new joint washer coated with Hylomar jointing compound. Ensure that the oil seal is pressed squarely against the face of the spacer and refit the differential housing, fit new locking plates, and lightly tighten the securing nuts.

Adjustment

- (15) Refit the end cover without a joint washer but with the original adjustment shims, tighten the cover bolts evenly and sufficiently only for the cover register to nip the bearing outer race; overtightening will distort the flange.

- (16) Take a feeler gauge measurement at varying positions between the side cover flange and the differential housing, any variations in measurement will indicate that the cover bolts are not evenly tightened. Adjust the cover bolts accordingly until identical measurements can be obtained. The compressed thickness of a new cover joint washer is .007 in. (.178 mm.) and the required preload on the bearings is .002 in. (.051 mm.). The correct gap is therefore .009 in. (.229 mm.), any deviation from this figure must be made up by adding or subtracting shims.

Example: If the feeler gauge measurement is .005 in. (.127 mm.), add a shim of .004 in. (.10 mm.) thickness between the bearing and the end cover.

- (17) Remove the end cover, fit shims as required, and refit the cover with a new joint washer coated with Hylomar jointing compound. Tighten the differential housing nuts and the cover bolts to the torque figures given in 'GENERAL DATA'. Tap up the locking plate tabs, except the nut which accepts the exhaust pipe bracket (fitted when the engine is in the car).
- (18) Lubricate the driving flange oil seal and refit the flanges making sure that the split collets are correctly located, inside the flanges. Fit new rubber seals to and refit the central securing bolts. Hold the flanges with Service tool 18G 1100 and tighten the flange bolts with Service tool 18G 372 to the torque figure given in 'GENERAL DATA'.
- (19) Refit the governor control linkage to the transmission case with a new washer. Ensure the lever is positioned correctly, relative to the governor (see Fig. Fa.22).
- (20) Carry out the 'Refitting' instructions given in Section Aa.3.

Section Fa.10

TOP AND REVERSE CLUTCH

Removing

- (1) Carry out the operations given in Section Fa.3, items (1), (2b), and (12).

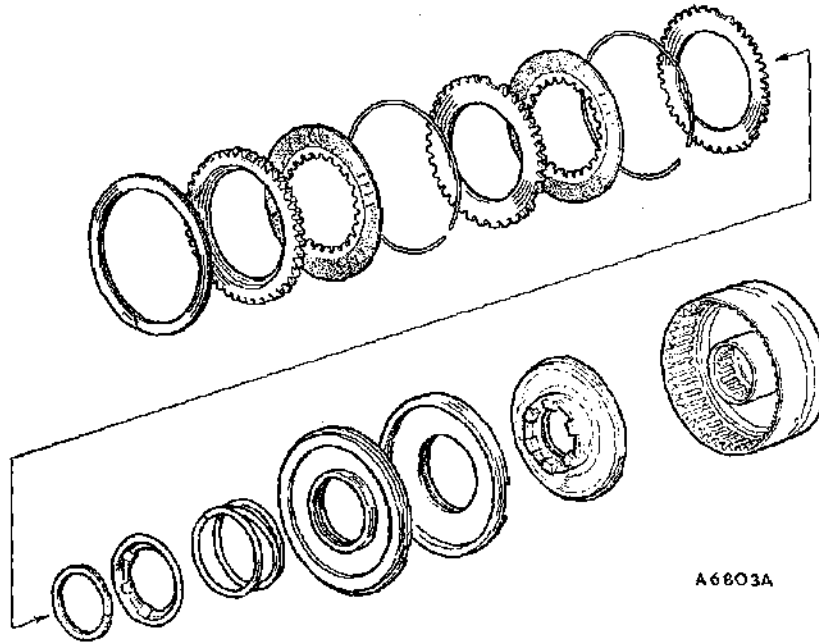

Fig. Fa.55

The top and reverse clutch components

- (2) Remove the top and reverse clutch from the gear train together with the Torrington needle thrust bearing and the steel washer.

Dismantling

- (3) Remove the double spring circlip.
- (4) Remove the retainer plate.
- (5) Lift out the paper plate, spring ring, steel plate, paper plate, spring ring, and the thin steel plate.
- (6) Remove the circlip, spring retainer, and the piston return coil spring.
- (7) Lightly shock the assembly against a flat surface to remove the top gear piston and cylinder.
- (8) Refit the reverse (booster) piston into the bore, easing the piston ring into the bore with a screwdriver.
- (9) Fit Service tool 18G 1103 into the clutch unit and holding these together, lightly shock the assembly against a flat surface to remove the reverse booster piston.

Inspecting

Check all parts for wear and renew if necessary. Renew the oil seals in the pistons. Check the piston ring gap which must be .016 to .020 in. (.4 mm. to .51 mm.), for both rings when fitted in their respective bores.

Reassembling

- (10) Refit the reverse gear booster piston with the boss facing outwards, using Service tool 18G 1103 (see Fig. Fa.56).

- (11) Refit the top gear piston into its cylinder with the boss facing outwards.
- (12) Fit the top gear piston and cylinder into the clutch housing, with the cut-aways on the rear outer edge of the cylinder opposite the holes in the clutch housing.
- (13) Refit the top gear piston return spring, spring retainer, and circlip.

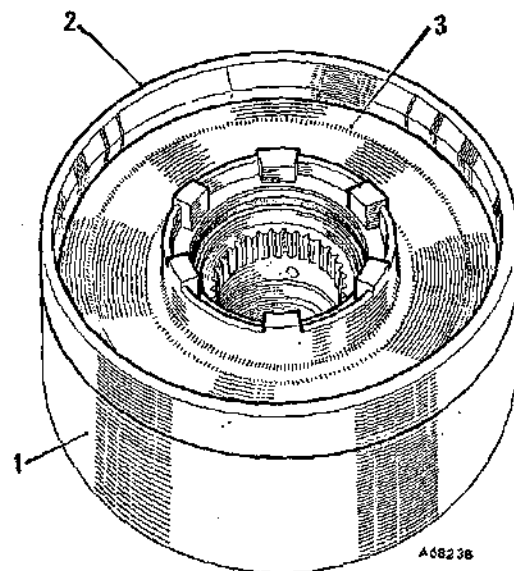

Fig. Fa.56

Using Service tool 18G 1103 (2) to remove or refit the reverse gear piston (3) to the top and reverse clutch unit (1)

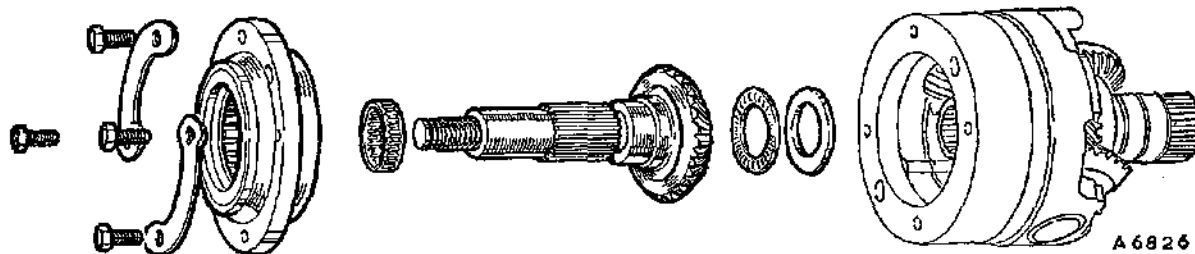

Fig. Fa.57

The one-way clutch removed from the gear train, with the input gear, bearings and thrust washer shown in assembly sequence

(14) Refit the clutch plates, aligning the cutaway in the steel plates (thin steel, spring ring, paper, steel, spring ring, paper).

(15) Refit the retainer plate and circlip.

NOTE.—Before refitting the clutch unit, ensure that the friction plates are free to drop.

Refitting

(16) Carry out the operations given in Section Fa.7, items (31) and (32).

(17) The remainder is a reversal of the removal procedure.

Inspecting

Check all parts for wear and renew if necessary.

Reassembling

(6) Reassemble the thrust bearing, intermediate spring ring, first gear free-wheel (lip facing outwards, see Fig. Fa.59), spring ring, and refit the circlip.

Refitting

(7) Refitting is a reversal of the removing procedure.

Section Fa.11

FIRST GEAR FREE-WHEEL ASSEMBLY (ONE-WAY CLUTCH)

Removing

- (1) Carry out the operation given in Section Fa.3, items (1), (2b), and (12).
- (2) Remove the first gear free-wheel reaction member.
- (3) Knock back the locking plate tabs and remove the retaining bolts and the first gear free-wheel (one-way clutch) from the housing.

Dismantling

- (4) Remove the circlip.
- (5) Lift out the spring ring, first gear free-wheel, intermediate spring ring, and thrust bearing (see Fig. Fa.58).

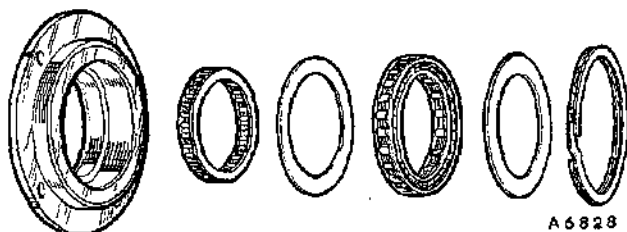

Fig. Fa.58

The components of the one-way clutch

Section Fa.12

GEAR-CHANGE CABLE

Removing

- (1) Remove the weather protection cover (if fitted) from the converter housing. Pull back the rubber sleeve and disconnect the gear-change cable by removing the clevis pin. Slacken the yoke clamp nut and remove the yoke, nut, rubber ferrules, and sleeve (see Fig. Fa.60). Remove the adjusting nuts from the outer cable and pull the cable clear of the transmission.
- (2) Release the cable clip from the floor panel.
- (3) Remove the front floor covering.
- (4) Disconnect the electrical leads from the inhibitor switch.

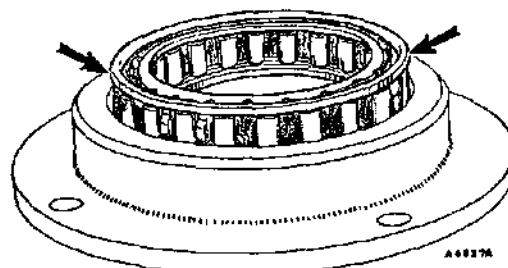

Fig. Fa.59

Fitting the one-way clutch with the lip (arrowed) correctly positioned, uppermost

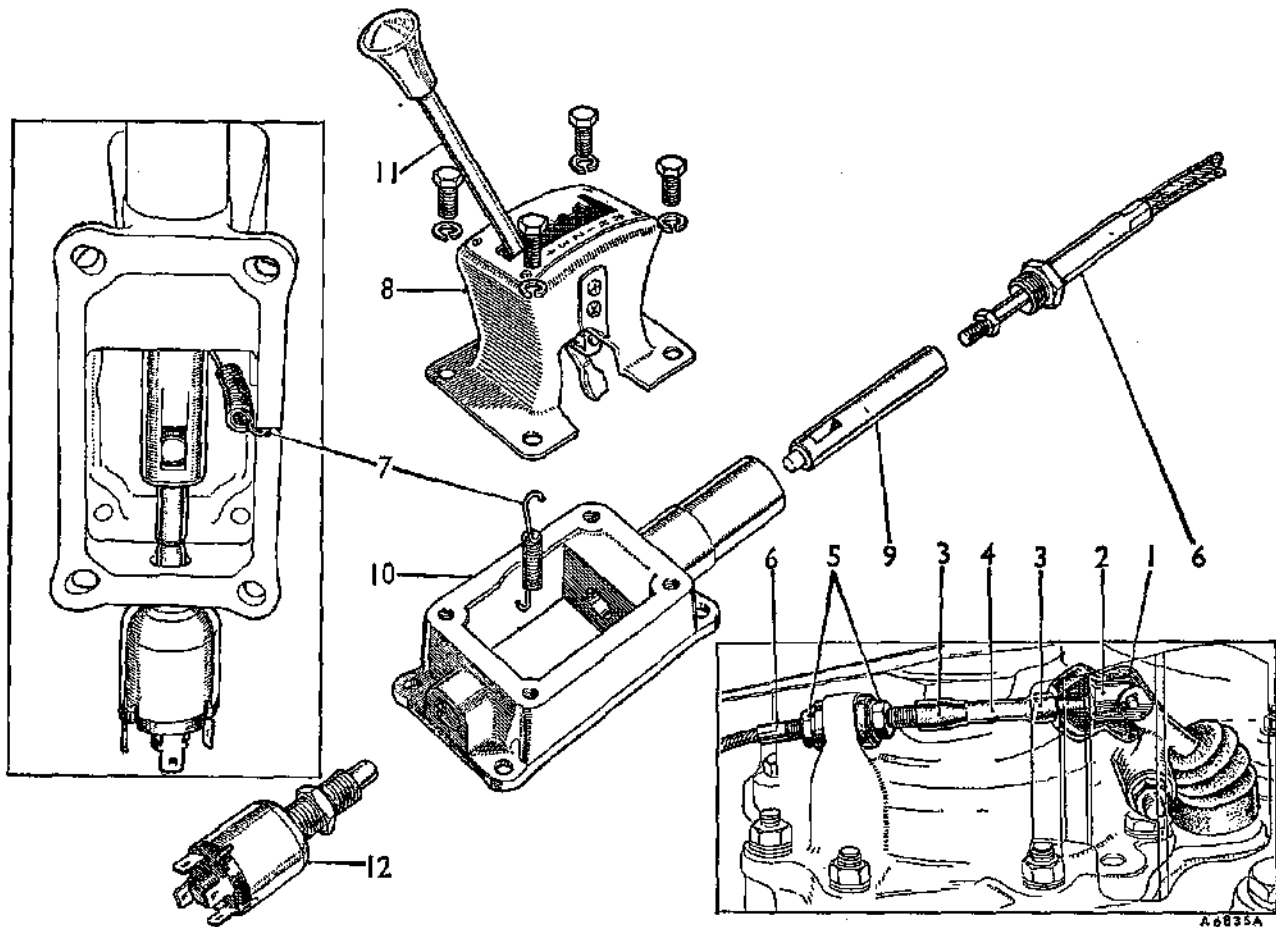

Fig. Fa.60

The gear-change housing and cable components. Insets show the reverse return spring location and the cable connections

- | | | |
|---------------------|---------------------------|--------------------------|
| 1. Rubber sleeve. | 5. Cable adjusting nuts. | 9. Lever plunger. |
| 2. Yoke. | 6. Cable. | 10. Gear-change housing. |
| 3. Rubber ferrules. | 7. Reverse return spring. | 11. Gear selector lever. |
| 4. Cable sleeve. | 8. Quadrant. | 12. Inhibitor switch. |

(5) Remove the screws securing the gear change housing, carefully pull the cable through the rubber dust excluder, and remove the housing and cable assembly.

Dismantling

(6) Hold the assembly in a vice and remove the set screws securing the quadrant to the housing. Release the reverse return spring from the base of the housing and remove the quadrant and lever assembly.

(7) Unscrew the cable securing nuts from the front of the housing, pull the cable from the housing and release it from the gear change lever plunger.

Inspecting

(8) Clean and inspect moving parts for wear.

Reassembling

(9) Lubricate all moving parts with grease.

(10) Reassembly is a reversal of the dismantling procedure.

Refitting

(11) Refitting is a reversal of the removing procedure.

(12) Adjust the inhibitor switch and the gear change cable and selector rod as detailed in Section Fa.2.

SECTION G

THE DRIVE SHAFTS

| | <i>Section</i> |
|----------------------------------|----------------|
| General description | |
| ● Drive shaft: | |
| Removing | G.1 |
| Overhaul | G.2 |
| Coupling replacement | G.3 |
| Universal joint overhaul | G.4 ● |

GENERAL DESCRIPTION

Each of the two drive shafts employed has two principle members incorporating a Hardy Spicer constant-velocity bell joint. The hemispherical interior of the bell joint and the exterior of the inner ball race have six grooves machined in line with the shaft axis, and a ball cage carrying six steel balls is interposed between the two. The steel balls engage the grooves of both members to key them together and at the same time allow the members to hinge freely upon each other.

The joint is packed with special grease and the unit is enclosed in a sealed rubber boot. The inner end of the drive shaft is splined and has a pre-lubricated sliding joint sealed with a rubber boot.

Section G.1

DRIVE SHAFTS

Removing

● To remove the drive shaft assembly from the vehicle follow the removing instructions given for swivel hubs in Section K.2. ●

The constant-velocity bell joint may be removed from the drive shaft for replacement as a unit or to have a Service kit fitted. Under no circumstances must individual components be replaced in the bell joint assembly.

Should a rubber boot enclosing the joint be damaged with a consequent loss of lubricant, it is necessary to remove the joint from the shaft for dismantling and inspection of the components.

If a rubber boot is damaged in the workshop and dirt has not entered the joint, a new boot may be fitted after first repacking the joint with the recommended grease.

To fit a new boot the drive shaft must be removed from the vehicle.

Constant-velocity (bell) joint

The bell joint can be removed from the drive shaft for dismantling and inspection of the components.

Service kits are available which include the required amount of lubricant to service a bell joint.

When servicing of the joint becomes necessary, the procedure given in Section G.2 must be followed.

Sliding joint flange

On later models the sliding joint is prepacked with $\frac{1}{2}$ oz. (21 gm.) of Duckham's M.B. grease (BMC pack AKF 1457) and sealed with a rubber housing seal, early models were fitted with lubricating nipple. When servicing the sliding joint or fitting a new seal, refer to Section G.2.

G.2

Section G.2

DRIVE SHAFT OVERHAUL

Dismantling the shaft assembly

- (1) Clean the shaft of road dirt and grease and mount the shaft centrally in a vice fitted with soft jaws.
- (2) Prise off the boot and housing seal clips or cut the soft iron wire, turn back the housing seal and slide off the joint flange. Remove the housing seal and the rubber boot, if they are worn or damaged, replacements must be fitted on reassembly.
- (3) The bell joint can only be dismantled after removal of the shaft; a round-section spring ring located in a deep groove in the extreme end of the shaft is expanded into the chamfered end of the inner race bore, and for shaft removal this must be contracted into the groove.
- (4) Hold the shaft and joint vertically, the bell joint downwards, and give the edge of the outer race a sharp tap with a soft faced mallet (see Fig. G.1). This should contract the spring ring so that the joint can be drawn off the shaft. It should not be necessary to use heavy blows for this operation.

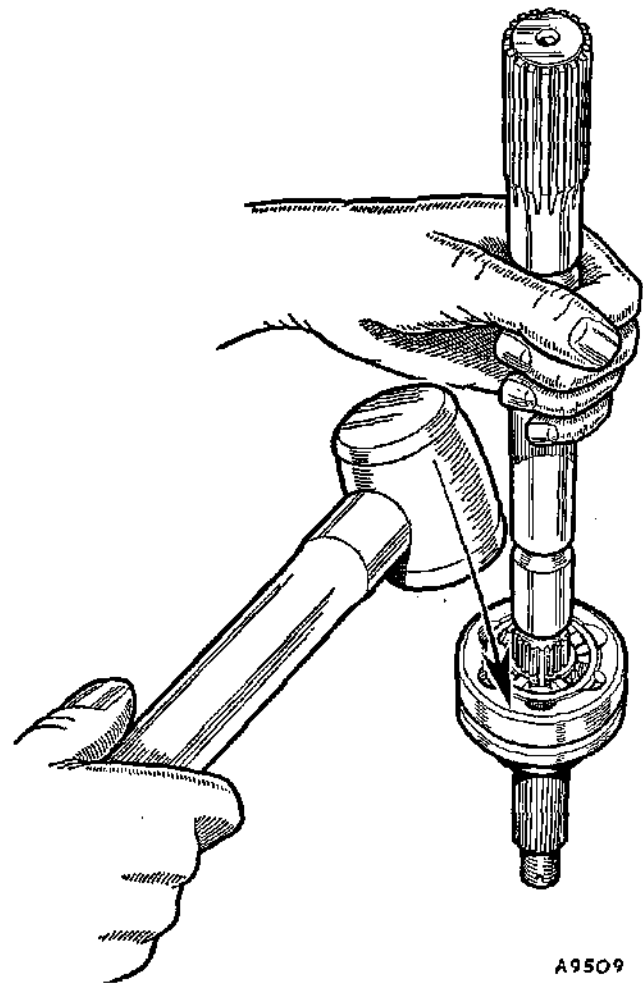

Fig. G.1

Drive the bell joint from the shaft at the point indicated

SECTION G
THE DRIVE SHAFTS

| | <i>Section</i> |
|---------------------|----------------|
| General description | |
| Removing | G.1 |
| Servicing | G.2 |

GENERAL DESCRIPTION

Each of the two drive shafts employed has two principle members incorporating a Hardy Spicer constant-velocity bell joint. The hemispherical interior of the bell joint and the exterior of the inner ball race have six grooves machined in line with the shaft axis, and a ball cage carrying six steel balls is interposed between the two. The steel balls engage the grooves of both members to key them together and at the same time allow the members to hinge freely upon each other.

The joint is packed with special grease and the unit is enclosed in a sealed rubber boot. The inner end of the drive shaft is splined and has a pre-lubricated sliding joint sealed with a rubber boot.

Section G.1

DRIVE SHAFTS

Removing

To remove the drive shaft assembly from the vehicle follow the removing instructions given for swivel hubs in Section K.3.

The constant-velocity bell joint may be removed from the drive shaft for replacement as a unit or to have a Service kit fitted. Under no circumstances must individual components be replaced in the bell joint assembly.

Should a rubber boot enclosing the joint be damaged with a consequent loss of lubricant, it is necessary to remove the joint from the shaft for dismantling and inspection of the components.

If a rubber boot is damaged in the workshop and dirt has not entered the joint, a new boot may be fitted after first repacking the joint with the recommended grease.

To fit a new boot the drive shaft must be removed from the vehicle.

Constant-velocity (bell) joint

The bell joint can be removed from the drive shaft for dismantling and inspection of the components.

Service kits are available which include the required amount of lubricant to service a bell joint.

When servicing of the joint becomes necessary, the procedure given in Section G.2 must be followed.

Sliding joint flange

On later models the sliding joint is prepacked with $\frac{1}{4}$ oz. (21 gm.) of Duckham's M.B. grease (BMC pack AKF 1457) and sealed with a rubber housing seal, early models were fitted with lubricating nipple. When servicing the sliding joint or fitting a new seal, refer to Section G.2.

G.2

Section G.2

SERVICING

Dismantling the shaft assembly

- (1) Clean the shaft of road dirt and grease and mount the shaft centrally in a vice fitted with soft jaws.
- (2) Prise off the boot and housing seal clips or cut the soft iron wire, turn back the housing seal and slide off the joint flange. Remove the housing seal and the rubber boot, if they are worn or damaged replacements must be fitted on reassembly.
- (3) The bell joint can only be dismantled after removal of the shaft; a round-section spring ring located in a deep groove in the extreme end of the shaft is expanded into the chamfered end of the inner race bore, and for shaft removal this must be contracted into the groove.
- (4) Hold the shaft and joint vertically, the bell joint downwards, and give the edge of the outer race a sharp tap with a soft faced mallet (see Fig. G.1). This should contract the spring ring so that the joint can be drawn off the shaft. It should not be necessary to use heavy blows for this operation.

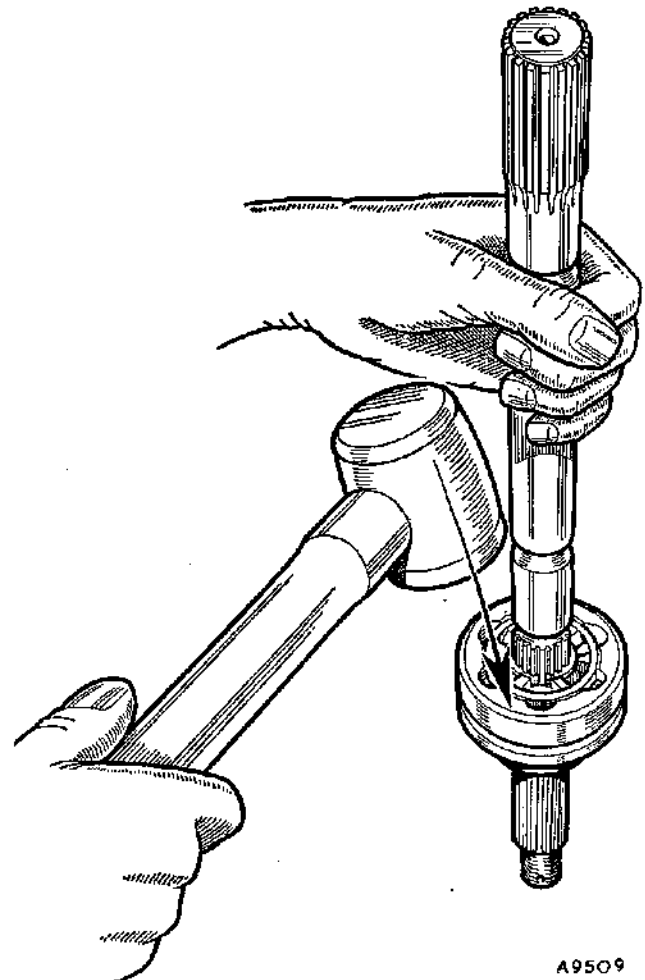

Fig. G.1

Drive the bell joint from the shaft at the point indicated

Dismantling the joint

- (5) The joint should be dismantled only if there is reason to believe that it is still serviceable.
- (6) As the components are mated and have operated together, they must be kept in the same mating relationship. The relative positions of the inner and outer races and the cage should be marked with blue marker or a paint which will not wash off when the parts are cleaned.
- (7) With the shaft withdrawn the inner race can swivel freely, tilt the inner race until one ball is released (Fig. G.2). Note that the cage swivels through half the angle of the inner race. If the joint is sticky with grease each ball may be eased out in turn with a pointed tool.
- (8) Swivel the cage into line with the axis of the joint and turn it until two opposite elongated windows coincide with two lands of the bell joint. One land will drop into a window, allowing the cage and race assembly to be lifted out (Fig. G.3).
- (9) Swivel the inner race at right angles to the cage and turn it until two of the lands between the inner race tracks are opposite elongated windows in the cage. One land will drop into a window, allowing the inner race to be extracted from the cage (Fig. G.4).

Inspecting

- (10) Clean all parts thoroughly in petrol (fuel), paraffin (kerosene), or white spirit and dry off. In normal service, wear should be distributed fairly evenly over all components and the joint will remain serviceable until the amount of end-float exceeds the acceptable wear maximum of .025 in. (.64 mm.).

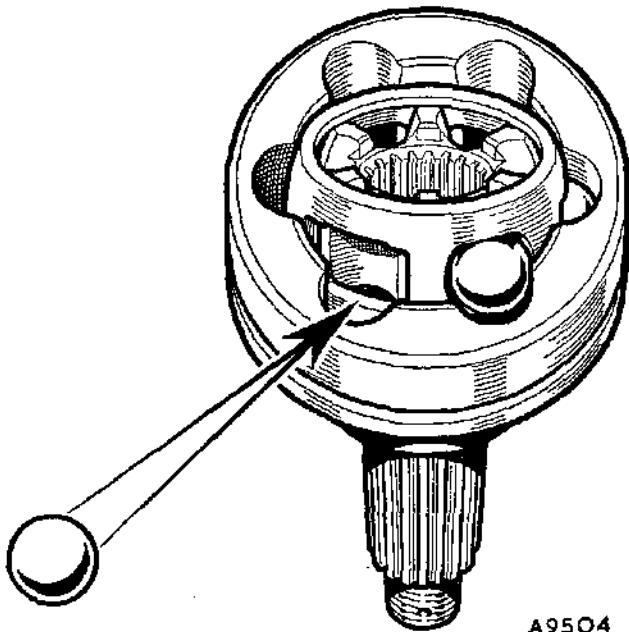

Fig. G.2

Tilt the inner race to remove or replace each ball in turn

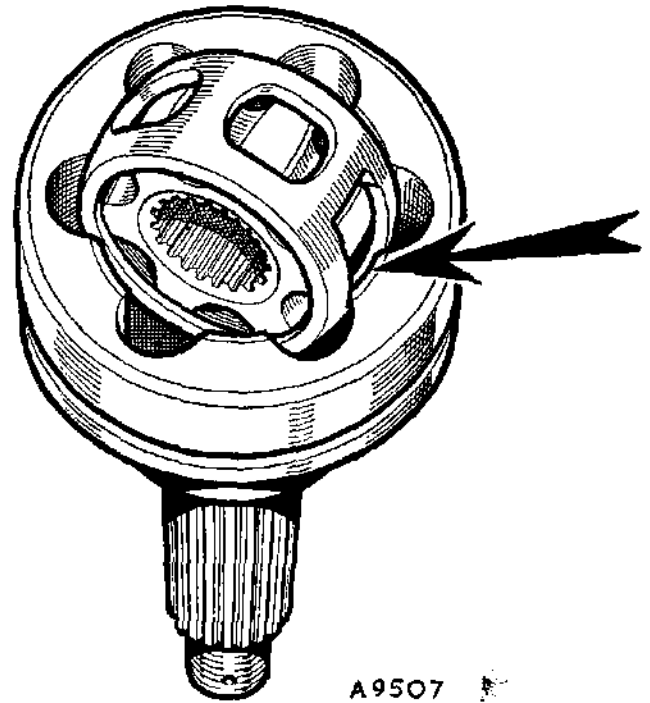

Fig. G.3

Removing the cage and inner race assembly, from the bell joint

- (11) Examine the six balls and if worn, rust-pitted or bearing evidence of flattening, the joint assembly must be replaced.
- (12) Inspect the inner and outer race tracks, these will be marked on the flanks where the balls roll, but should be free from indentation and the marking should be consistent.
- (13) Inspect the inner and outer spherical surfaces of the cage and the corresponding surfaces of the inner and outer races; these will be polished by contact but must be free from any sign of 'picking-up'. The edges of the cage windows may show signs of wear towards the outer side. Wear at these points may cause knocking when the joint is operated at high angles.
- (14) Carefully examine the shaft for cracks, and ensure that the square-section outer circlip is firmly in its groove.

Replacing the ball cage

The majority of cages used in the original assembly are of a standard size, although on some shafts two other non-standard oversize cages have also been used, and all three may be encountered in Service.

It is important to note that a joint will only accept a replacement cage of the same size as the original.

To effect easy identification of cage sizes use Service tool 18G 1012. The fitting of a Service kit must not be attempted without this tool.

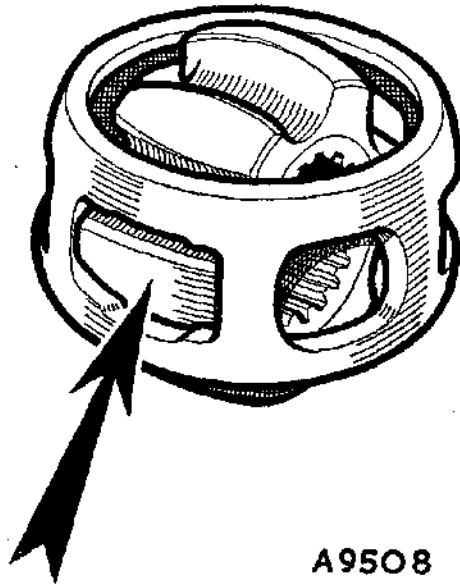

Fig. G.4

Manœuvre the inner race in the cage to the required position to allow it to be extracted

The three kits available are as follows:

- Kit 'A', Part No. 18G 8000 (Standard)
- Kit 'B', Part No. 18G 8002 (.004 in. oversize)
- Kit 'C', Part No. 18G 8001 (.010 in. oversize)

It is extremely difficult to check the ball cage internal dimensions and a gauge, Service tool 18G 1012, must be used to determine the size of the cage fitted.

- (15) The small bore of the gauge is a clearance fit over a standard inner race but will not accept an inner race .004 in. (.100 mm.) oversize. The larger bore of the tool is a clearance fit over a standard cage but will not accept a cage .010 in. (.25 mm.) oversize.
- (A) If the inner race passes through the small bore of the gauge, and the cage passes through the larger bore, the joint is size 'A'.
- (B) If the inner race will not pass through the gauge, the joint is size 'B'. The cage should also be checked, but must be accepted by the gauge.
- (C) If the inner race passes through the gauge, but the cage will not pass through, the joint is size 'C'.

NOTE.—Should the gauge 18G 1012 not accept the inner race or cage, the joints must be replaced as a unit.

Reassembling the joint

- (16) This is an exact reversal of the dismantling procedure. All components should be lightly lubricated with Duckham's M-B grease (BMC pack AKF 1457). The components should go together easily and no force should be required.

- (17) Insert the inner race into the cage by introducing one of the lands into an elongated window in the cage (Fig. G.4).
- (18) Insert the cage and inner race assembly into the bell joint by fitting one of the elongated windows over one of the lands in the outer race (Fig. G.3). The three parts can now be turned or swivelled freely in relation to each other.
- (19) Locate the cage and inner race in their original position relative to the bell joint (as marked before dismantling).
- (20) Keeping this relationship between the parts, tilt the cage until one ball can be inserted in a window. Repeat this operation with the remaining balls (Fig. G.2).
- (21) Ensure that the inner race articulates freely with the cage in the bell joint, but care must be taken not to release the balls.
- (22) The joint should be filled with the remainder of the pack of Duckham's M-B grease, before inserting the shaft.
- (23) Fit a new rubber boot if necessary, smearing the inside with Duckham's M-B grease, take care when easing the boot over the circlip on the shaft.

Assembling the shaft to the joint

- (24) Replace the round-section spring ring with a new one (Fig. G.5). If replacing the shaft, fit a new circlip.

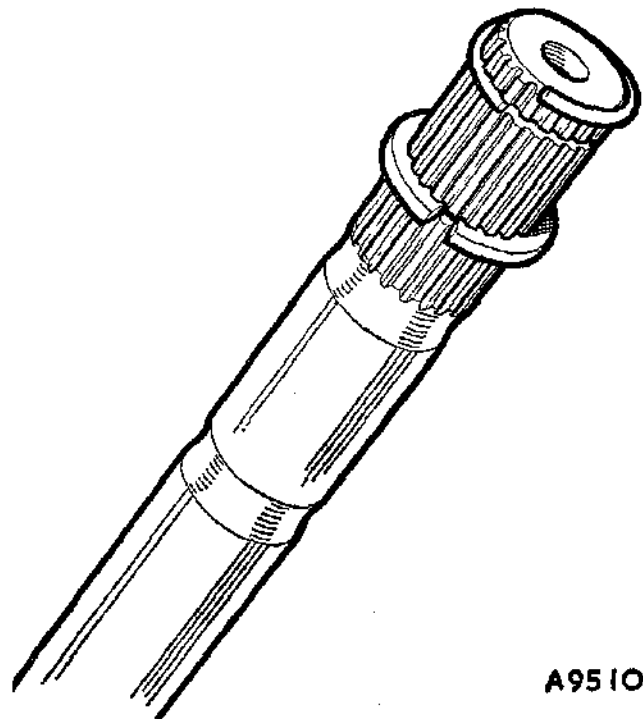
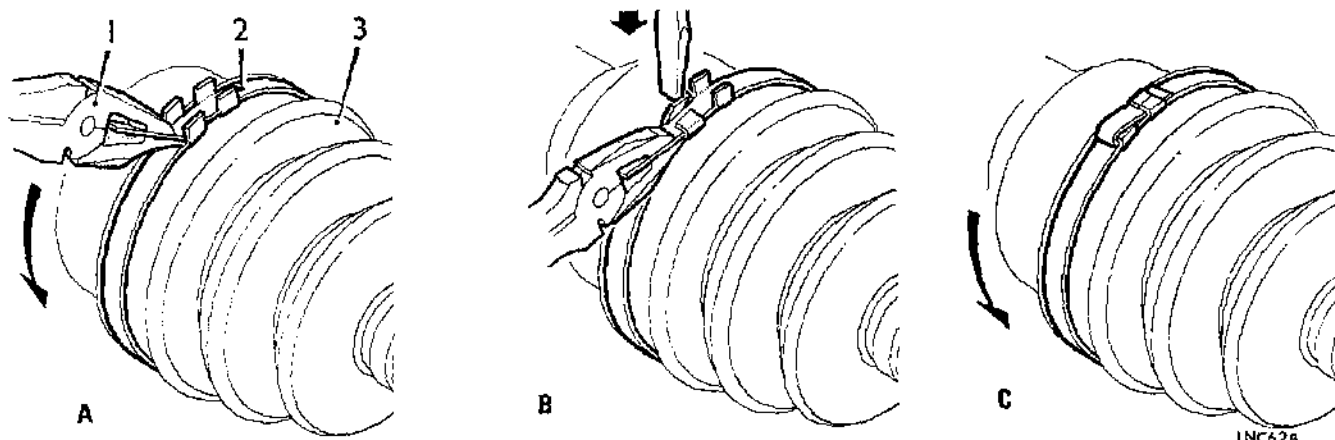

Fig. G.5

The splined bell joint end of the drive shaft showing the circlip and the round-section spring ring



●Fig. G.6

Securing the rubber boot to the drive shaft bell joint. 'Arrows' indicate forward rotation of drive shaft

1. Service tool 18G 1099. 2. Clinching clip. 3. Rubber boot (modified type). ●

(25) Hold the shaft in a vice and locate the inner race on the shaft. Press the joint assembly against the spring ring whilst locating the ring centrally and contracting it in the chamfer of the inner race with screwdrivers. With the spring ring centralized, a sharp tap on the end of the stub shaft with a soft faced mallet will close up the ring, and the assembly can then be tapped on to the drive shaft. Make sure that the shaft is fully engaged, with the inner race against the circlip and that the inner ring has expanded inside the joint.

(26) Slide the rubber boot over the bell joint until the radiused rib registers in the locating groove, and secure it with the large clinching clip using Service tool 18G 1099 (Fig. G.6). This is fitted with the tab pulled through away from the direction of forward rotation. Locate the other end of the boot in the groove in the drive shaft and secure it with the small clinching clip using pliers 18G 1099.

●NOTE.—A modified rubber boot which has axial convolutions (see Fig. G.6) should be fitted when a replacement is required. ●

(27) Lubricate the yoke end of the drive shaft and the inside of the yoke housing seal and slide the seal onto the shaft. Fill the cavity in the sliding joint yoke with $\frac{3}{4}$ oz. (21 gm.) of Duckham's M-B grease and fit the yoke to the shaft. Locate the seal into the groove on the shaft and the other end over the sleeve location. Push the shaft to the bottom of the yoke so that grease is driven into the seal. Hold the outer lip of the seal open to allow air and surplus grease to escape, ensure that the diameter of the bellows does not exceed 1.75 in. (44.5 mm.). Secure the yoke seal with clinching clips using pliers 18G 1099.

●Refitting

(28) Refitting is a reversal of the removing procedure given in Section K.2. ●

(29) When fitting a replacement drive shaft assembly (of the type fitted with a rubber boot on the sliding joint) to the left-hand side of an early model, it will also be necessary to fit a modified lower arm inner pivot pin to ensure sufficient clearance for the rubber boot. Reference should be made to Fig. G.7 for the dimension of the modified pivot pin.

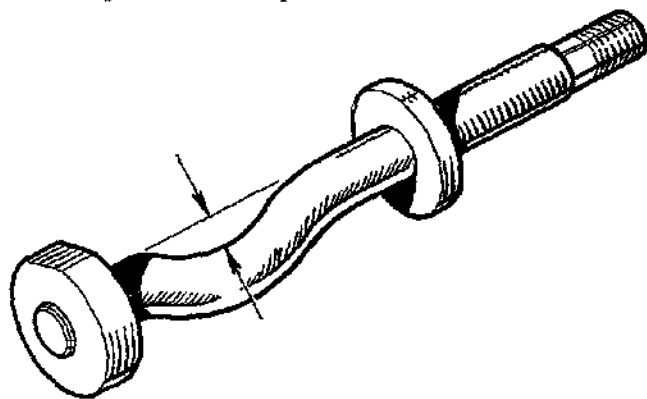

Fig. G.7

The lower arm pivot pin. The measurement at the position indicated must be .312 in. (7.9 mm.) to accommodate the rubber boot of later drive shaft assemblies

●Section G.3

DRIVE SHAFT COUPLING

Removing

- (1) Jack up the front of the vehicle, place supports under the sub-frame and remove the road wheel.
- (2) Remove the upper and lower swivel hub ball pin retaining nuts and release the ball pins from the suspension arms using Service tool 18G 1063.
- (3) Remove the 'U' bolts and nuts securing the drive flange coupling.

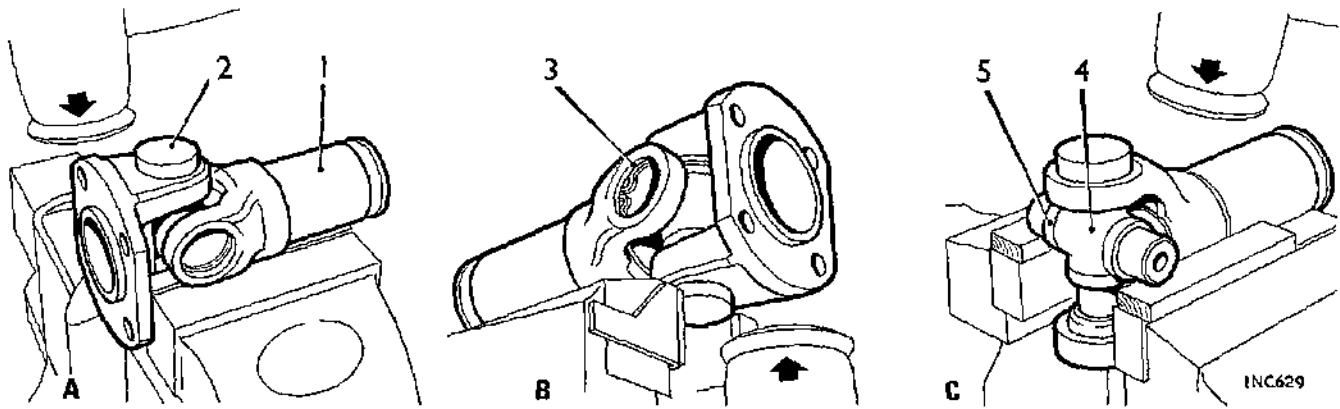

●Fig. G.8

The sequence of operations when removing the needle bearings from the universal joint

- | | | |
|-------------------------|-----------------------|-------------------|
| 1. Yoke. | 3. Retaining circlip. | 5. Rubber seal. ● |
| 2. Needle bearing race. | 4. Journal spider. | |

- (4) Disconnect the swivel hub assembly from the suspension arms and pull it out sufficiently to release the rubber coupling.
NOTE.—Support the swivel hub on a stand or suitable support until it is refitted, do not stretch the hydraulic brake hose.

Refitting

- (5) Before refitting, check that the coupling 'U' bolts will easily engage the drive shaft yoke. If they have opened, squeeze both threaded ends together in a soft jawed vice until they are in alignment.
NOTE.—When reassembling, fit new 'U' bolt nuts.
- (6) Fit the new coupling to the final drive yoke.
- (7) Refit the swivel hub assembly to the suspension arms and at the same time engage the drive shaft yoke with the new coupling.
- (8) Tighten the new nuts on the coupling 'U' bolts equally until approximately $\frac{1}{8}$ in. (1.6 mm.) of thread extrudes through the nuts.
- (9) Tighten the swivel hub ball pin retaining nuts to the torque figure given in 'GENERAL DATA'.
- (10) Refit the road wheel and lower the car. ●

●Section G.4

UNIVERSAL JOINT OVERHAUL (Cooper 'S' and Automatic models)

Removing

- (1) Remove the drive shaft and swivel hub assembly as detailed in Section K.2, operations (1) to (7).
- (2) Remove the clinching clip securing the yoke housing seal to the drive shaft and pull the yoke housing assembly off the drive shaft splines.

Dismantling

- (3) Clean the universal joint assembly.
- (4) Remove the bearing retaining clips with a pair of thin-nosed pliers and prise them out with a screwdriver. If a retaining clip cannot be removed easily, tap the end of the bearing race to relieve pressure on the clip.
- (5) Hold the joint in one hand and support the underside of the yoke on the top of a vice. Tap the radius of the yoke lightly with a copper mallet, Fig. G.8, until the bearing race emerges from the yoke.
- (6) Turn the joint over and grip the bearing race in the vice. Tap the underside of the yoke until the bearing race is extracted, Fig. G.8.
- (7) Repeat operations (5) and (6) on the opposite bearing.
- (8) Support the two exposed bearing trunnions on the top of the vice (with wood or soft metal packings between the vice and the bearing trunnions). Tap the top lug of the flange yoke as detailed in operations (5) and (6) to extract the two remaining bearing races, Fig. G.8.
- (9) Withdraw the journal spider from the drive shaft yoke.

Inspecting

- (10) Wash all parts thoroughly in a cleaning fluid.
- (11) Check the bearing races and spider for signs of wear or load markings. Fit a new journal repair kit if any components are defective. Check that the bearing races are a light drive fit in the yoke trunnions, if any of the races are a loose fit, replace the complete end assembly.

Reassembling

- (12) Ensure that each bearing race has a complete set of needle rollers, smear the inside walls of the races and needle roller bearings with grease, with a $\frac{1}{2}$ in. (3 mm.) depth of grease in the end of each race.

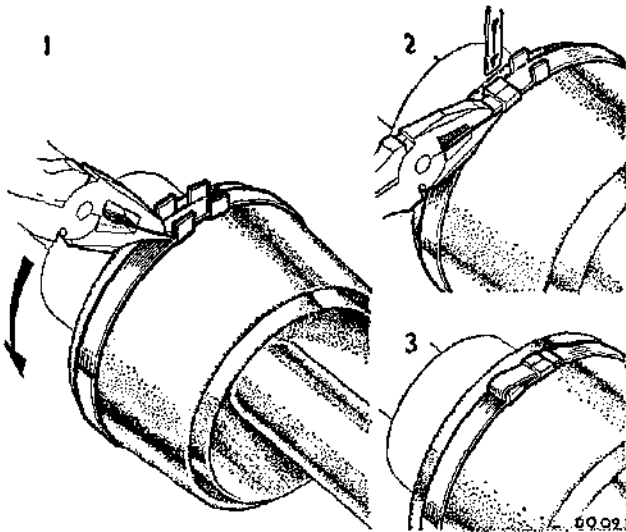

Fig. G.6

Fitting the clinching clips using Service tool 18G 1099. Pull the clip tightly between the tabs and secure in the order shown

- (25) Hold the shaft in a vice and locate the inner race on the shaft. Press the joint assembly against the spring ring whilst locating the ring centrally and contracting it in the chamfer of the inner race with screwdrivers. With the spring ring centralized, a sharp tap on the end of the stub shaft with a soft faced mallet will close up the ring, and the assembly can then be tapped on to the drive shaft. Make sure that the shaft is fully engaged, with the inner race against the circlip and that the inner ring has expanded inside the joint.
- (26) Slide the rubber boot over the bell joint until the radiused rib registers in the locating groove, and secure it with the large clinching clip using Service tool 18G 1099 (Fig. G.6). This is fitted with the tab pulled through away from the direction of forward rotation. Locate the other end of the boot in the groove in the drive shaft and secure it with the small clinching clip using pliers 18G 1099.

- (27) Lubricate the yoke end of the drive shaft and the inside of the yoke housing seal and slide the seal onto the shaft. Fill the cavity in the sliding joint yoke with $\frac{3}{4}$ oz. (21 gm.) of Duckham's M-B grease and fit the yoke to the shaft. Locate the seal into the groove on the shaft and the other end over the sleeve location. Push the shaft to the bottom of the yoke so that grease is driven into the seal. Hold the outer lip of the seal open to allow air and surplus grease to escape, ensure that the diameter of the bellows does not exceed 1.75 in. (44.5 mm.). Secure the yoke seal with clinching clips using pliers 18G 1099.

Refitting

- (28) Refitting is a reversal of the removing procedure given in Section K.3.
- (29) When fitting a replacement drive shaft assembly (of the type fitted with a rubber boot on the sliding joint) to the left-hand side of an early model, it will also be necessary to fit a modified lower arm inner pivot pin to ensure sufficient clearance for the rubber boot. Reference should be made to Fig. G.7 for the dimension of the modified pivot pin.

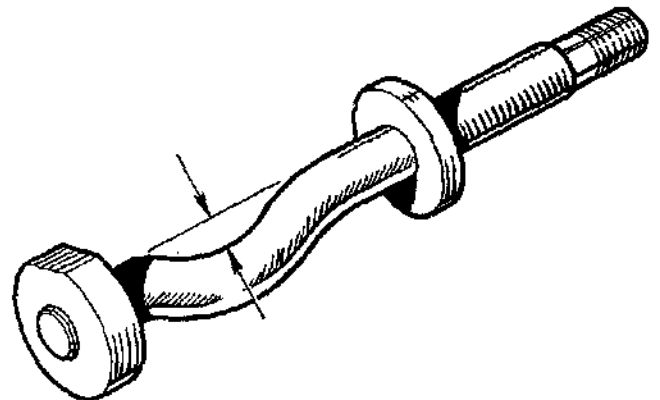
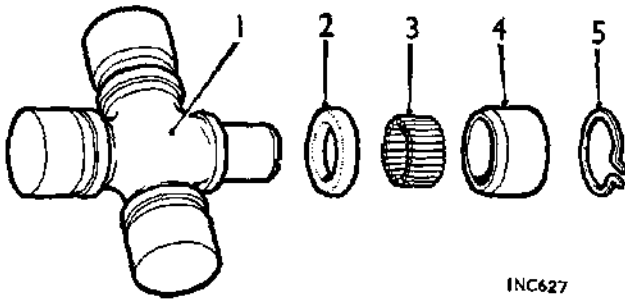

Fig. G.7

The lower arm pivot pin. The measurement at the position indicated must be .312 in. (7.9 mm.) to accommodate the rubber boot of later drive shaft assemblies





● Fig. G.9

The universal joint bearing components

- | | |
|-------------------------|--------------------|
| 1. Journal spider. | 3. Needle rollers. |
| 2. Rubber seal. | 4. Bearing race. |
| 5. Retaining circlip. ● | |

- (13) Check that yoke journal bearing apertures are clean and dry and insert the spider into the yoke.

- (14) Use a soft drift slightly smaller in diameter than the bearing race and tap the race into position; hold the spider into the race as it is drifted into position to retain the needle rollers in position.
- (15) Repeat the above operation on the opposite side of the yoke.
- (16) Engage the other journal over the spider and repeat operations (14) and (15).
- (17) Fit the circlips and ensure that they are firmly located in their grooves. If the joint appears to bind, tap the yoke journals lightly with a wooden mallet to relieve pressure of the bearing races on the ends of the journals.

Refitting

- (18) Fit a new rubber boot and refill it with the recommended grease as detailed in operation (27) of Section G.2.
- (19) Refit the drive shaft to the swivel hub and re-assemble the complete assembly to the vehicle as detailed in operations (19) to (24) of Section K.2. ●

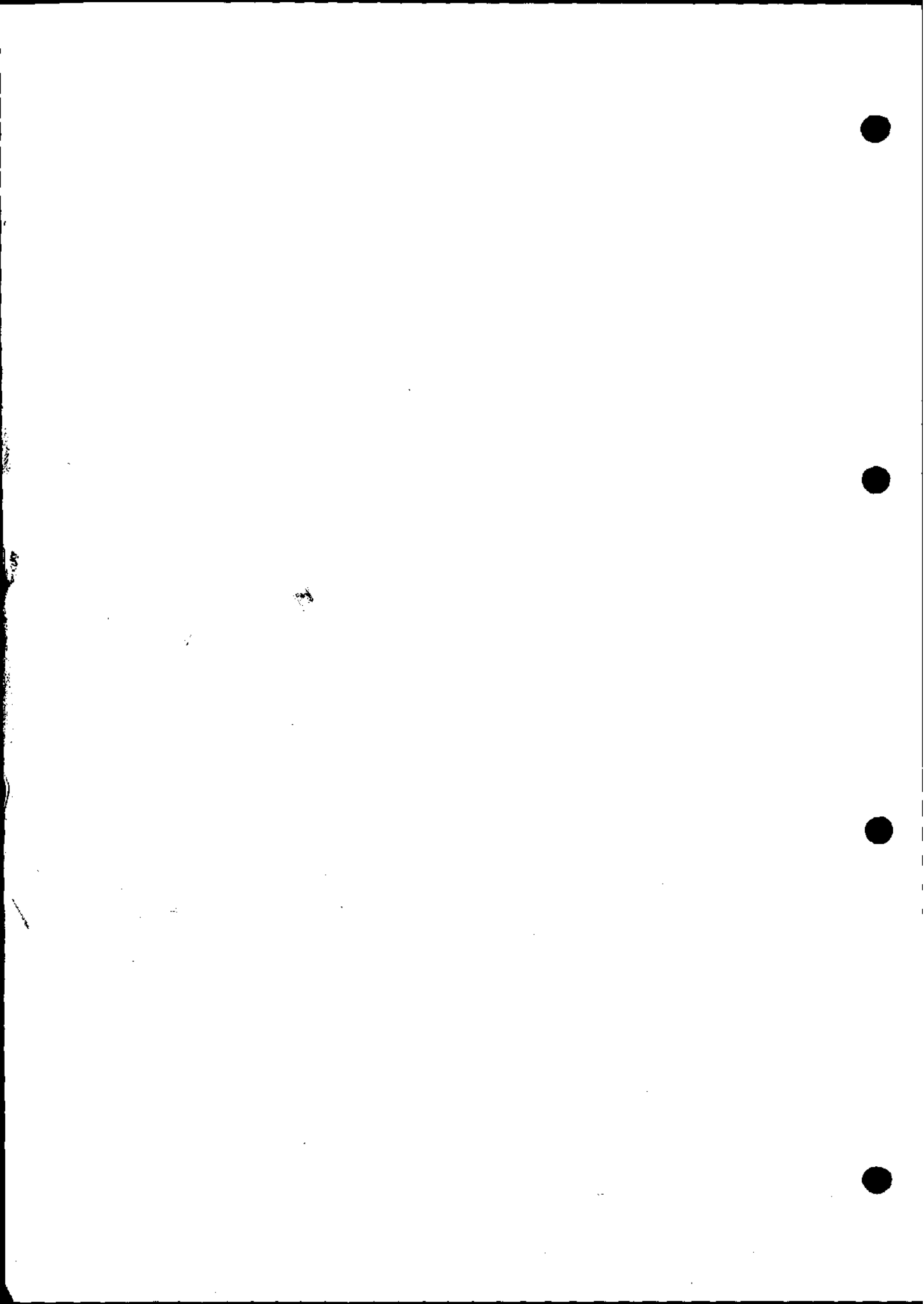

SECTION H
THE REAR SUSPENSION

| | <i>Section</i> |
|--|----------------|
| Hubs | H.5 |
| Hydroelastic suspension | H.6 |
| Depressurizing, evacuating, pressurizing | H.7 |
| Displacer units | H.8 |
| Radius arms | H.10 |
| Schrader valve extension housing | H.14 |
| Sub-frame | H.11 |
| Suspension pressures and wing heights | H.9 |
| Radius arms | H.2 |
| Radius arms (Moke) | H.13 |
| Spring units | H.3 |
| Sub-frame | H.1 |
| Sub-frame (Moke) | H.12 |
| Sub-frame mountings | H.4 |

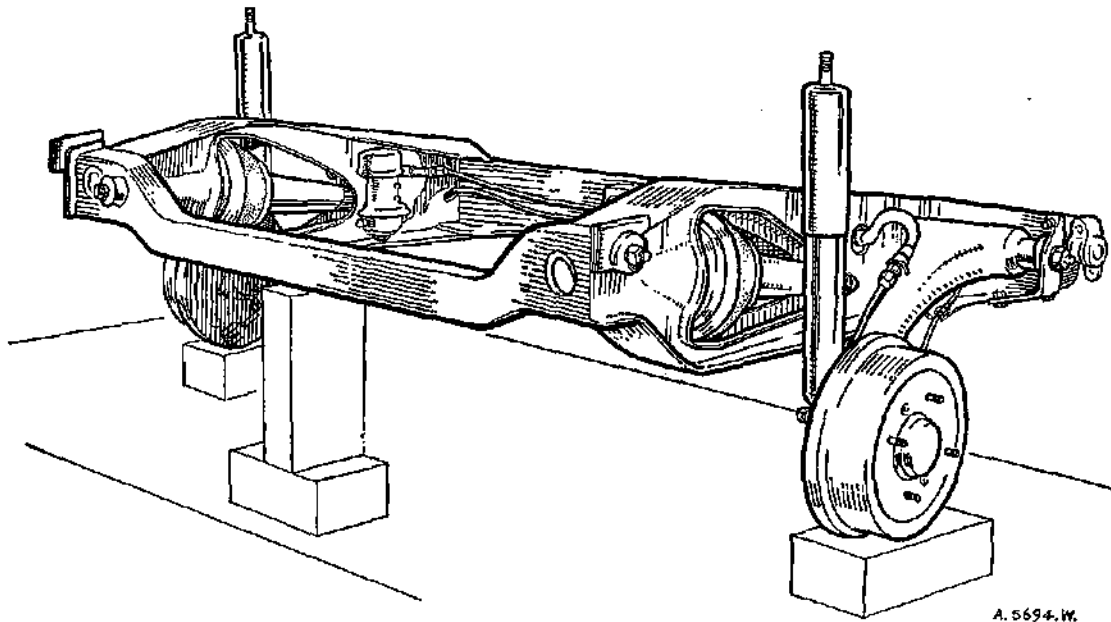

Fig. H.1

The rear sub-frame assembly (rubber suspension)

Section H.1

SUB-FRAME

Removing

- (1) Disconnect the battery.
- (2) Remove the exhaust pipe (Section A.3).
- (3) Disconnect the hydraulic pipe from the pressure regulating valve.
- (4) Remove the end finishers from the sill panels.
- (5) Release the rear dampers from inside the luggage compartment as in Section L.1.
- (6) Release the hand brake cable fairleads and disconnect the cables from the lever trunnion. Pull the cables downwards through the floor.
- (7) Lift the body with padded hooks under the wings.
- (8) Unscrew the eight sub-frame mounting bolts and withdraw the sub-frame.

Refitting

Reverse the removing instructions.

Section H.2

RADIUS ARMS

Removing

- (1) Release the rear damper(s) as in Section L.1.
- (2) Raise the car and support it under the sub-frame side-member.
- (3) Remove the road wheel.
- (4) Disconnect the brake hose from the bracket on the radius arm.

- (5) Prise out the strut assembly (Fig. H.2). The nylon cup may remain in the boss on the radius arm and, unless damaged, it can be removed with the fingers.
- (6) Disconnect the hand brake cable from the lever on the backplate, prise the guide tube from the clip on the arm and pull the tube away from the arm. On later models remove the nut from the cable sector pivot and withdraw the selector and pivot.
- (7) Remove the end finisher from the sill panel.
- (8) Unscrew the nut and remove the washer from the radius arm pivot shaft and lift the arm away from the car.

Dismantling and overhauling

- (9) Slide the dust seal and washer from the ends of the pivot.
- (10) If new bearings are necessary, withdraw the outer bronze bush with Service tool 18G 585 and fit the new bush with Service tool 18G 584.
- (11) Remove the needle-roller bearing from the inner end with Service tools 18G 583 and 18G 583 B and ream the outer bronze bush with Service tools 18G 588 and 18G 588 A.
- (12) Refit the needle-roller bearing with Service tool 18G 620, the marked end of the bearing faces outwards.
- (13) Lubricate all parts with grease.

Refitting

- (14) Reverse the removal instructions, but note:
- (15) Refers to item (5). Repack the nylon cup and dust seal with Dextragrease Super G.P. Lip the dust seal over the edge of the cup.

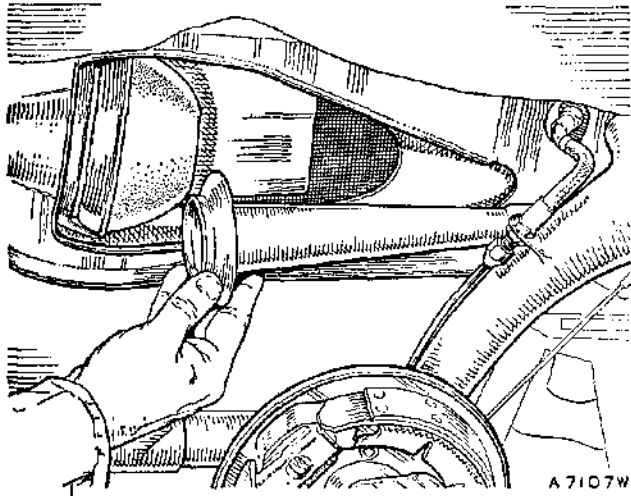

Fig. H.2

Extract the strut from the spring unit and pull it rearwards to disengage the ball end from the radius arm

Section H.3

SPRING UNITS

Removing

- (1) Carry out instructions (1) to (3) and (5) in Section H.2.
- (2) Remove the spring unit.
- (3) Prise out the nylon seating.

Refitting

- (4) Reverse the removing instructions, but note:
- (5) Make sure that the spring unit and spring strut are correctly located in their spigots while the radius arm is being raised to connect the upper end of the damper.

Section H.4

SUB-FRAME MOUNTINGS

Removing

- (1) Jack up the car at a point near the bumper and the rear body panel.

Front

- (2) Remove the radius arm (Section H.2).
- (3) Unscrew and remove the nut securing the mounting support pin to the sub-frame (Fig. H.3). Withdraw the mounting block to body screws. Prise the body and sub-frame apart sufficiently to allow the support pin, blocks, and rubbers to be extracted.

Rear

- (4) Jack up the car at a point between the bumper and the rear body panel.
- (5) Withdraw the mounting block to body screws and remove the nut from the end of the mounting support pin.
- (6) Prise the body and frame apart sufficiently to allow the block and rubbers to be removed.

Refitting

- (7) Reverse the removing instructions. Insert the mounting block to body screws before tightening the support pin nut.

Section H.5

HUB

Removing

- (1) Jack up the car and remove the road wheel and the brake-drum.
- (2) Prise off the hub cap.
- (3) Extract the split pin and screw the nut from the end of the stub shaft.
- (4) Withdraw the hub assembly.

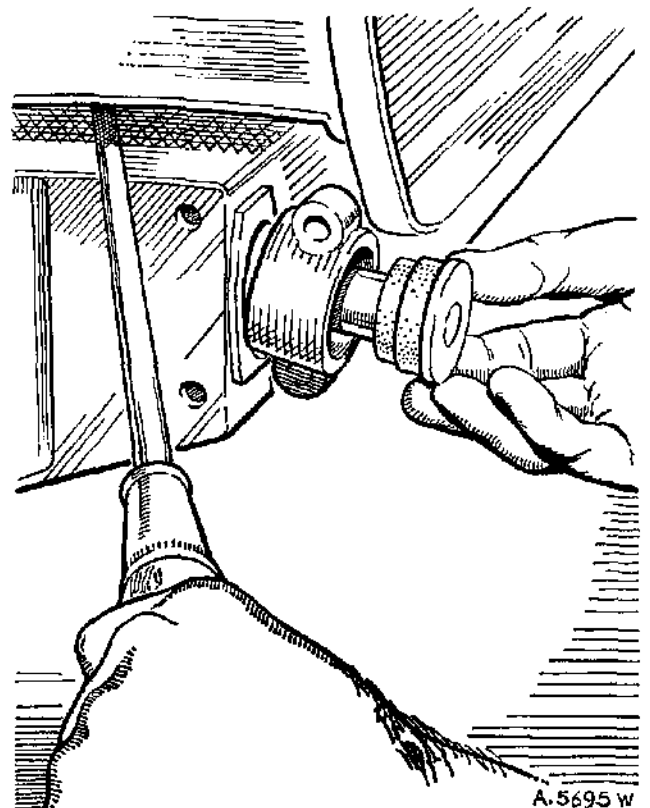

Fig. H.3

Removing the rear sub-frame front mounting support pin assembly

Dismantling

- (5) Drift the inner races of both bearings from the hub.
- (6) Remove the seal.
- (7) Extract the outer bearing races with Service tool 18G 260 and adaptor 18G 260 C.

Reassembling

- (8) Reverse the dismantling instructions and pack the bearings only with grease.

Refitting

- (9) Reverse the removing instructions, taking care to fit the chamfered bore of the thrust washer on the stub shaft towards the bearing.

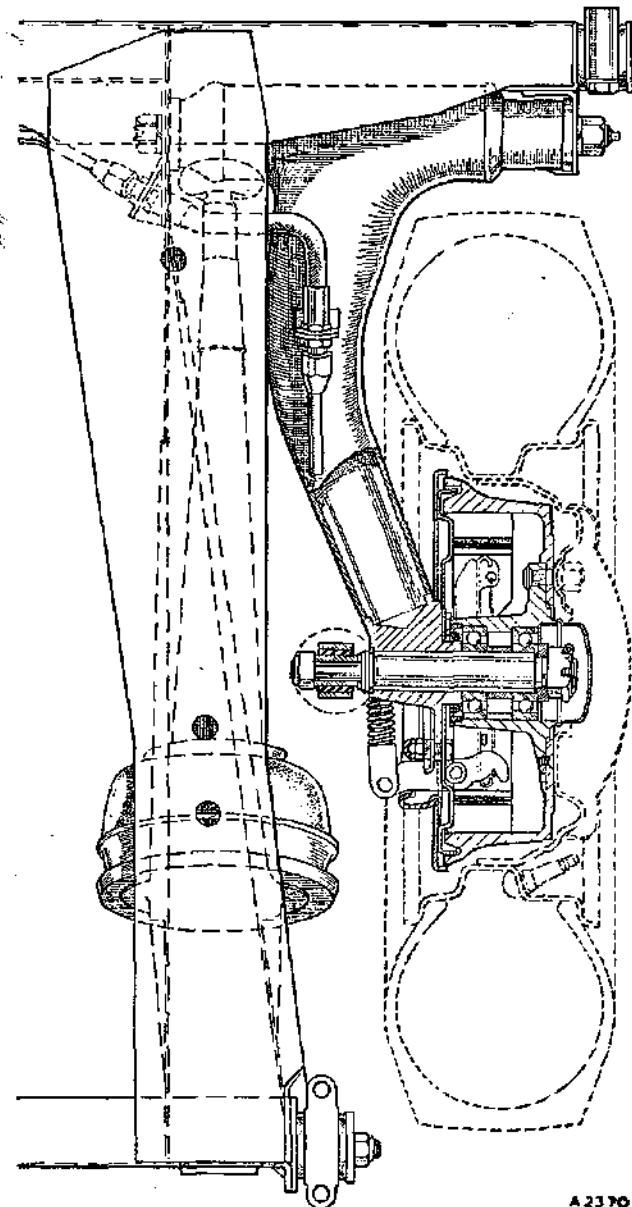

A 2370

Fig. H.4

The rear radius arm, showing a section through the hub assembly

Section H.6**HYDROLASTIC SUSPENSION**

The system consists of two front and two rear displacer units intercoupled longitudinally. Each is made of sheet steel and rubber and consists of a piston, a diaphragm, a lower and upper chamber housing, and a conical spring of compressed rubber.

Contact of the front wheels with a road irregularity forces the piston to push the diaphragm up; increased pressure displaces some of the fluid from the bottom chamber to the top chamber. The rubber springs deflect due to the pressure increase and fluid displacement, and the resultant pressure increase causes fluid to discharge through the interconnecting pipe into the rear displacer unit.

The fluid entering the rear displacer forces the diaphragm to react against the piston, resulting in the car height at the rear being raised. These events are virtually simultaneous and the car therefore rides an obstruction without pitch motion of the body. The action of the suspension is similar when the rear wheels negotiate the irregularity.

The fluid used in the system is a mixture of water and alcohol into which an anti-corrosive agent has been introduced.

The front suspension also comprises upper and lower arms of unequal length located in the side-members of the front sub-frame with their outer ends attached by ball joints to the swivel hubs.

The rear suspension, in addition to the Hydrolastic units, consists of independent trailing arms with auxiliary coil springs.

Section H.7**DEPRESSURIZING, EVACUATING, AND PRESSURIZING THE HYDROLASTIC SYSTEM**

Before any major work can be carried out on the suspension and its components the Hydrolastic system must be depressurized and in some cases evacuated. For this operation Service equipment Part No. 18G 703 or 18G 682 must be connected to the pressure valves on the rear sub-frame.

Before using Service equipment 18G 703 check that the pressure/vacuum tank is filled to the level indicated at the rear of the unit. The vacuum and pressure valves are identified by colour only; vacuum (yellow) and pressure (black).

Early service equipment (18G 682) has separate fillers for the pressure and vacuum tanks and are filled to the level shown on the dipstick. One side of the dipstick shows the level in the pressure tank and the other side the level in the vacuum tank.

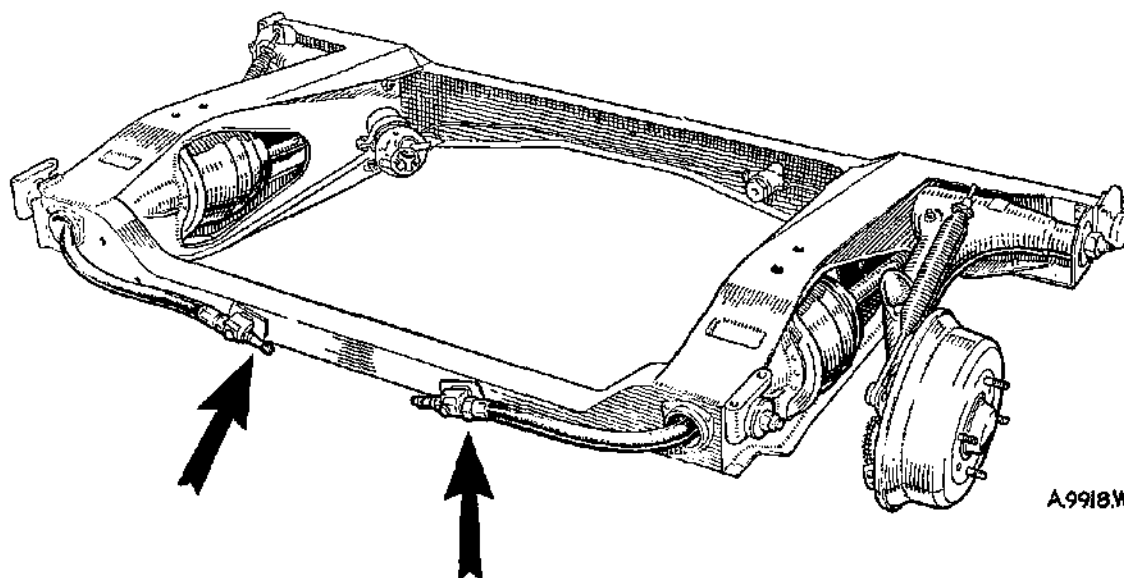

Fig. H.5

The Hydrolastic system pressure valves on the rear sub-frame

Top up to the correct levels with Hydrolastic Fluid, BMC Part No. 97H 2801.

The vacuum and pressure valves are identified by number or colour; vacuum (1) yellow, and pressure (2) black.

Depressurizing

- (1) Remove the pressure valve dust cap and connect the black connector to the valve with the knurled knob unscrewed.
- (2) Open the black valve (valve 2) and screw in the knurled knob to release the fluid from the suspension system into the unit's pressure tank.
- (3) Close the black valve (valve 2). The gauge should read zero if all the pressure has been released.
- (4) Remove the black connector and replace the pressure valve dust cap, and the plug in the black connector.
- (5) Repeat the above procedure on the second valve to depressurize the other side of the system.

Evacuating

After fitting new interconnecting pipes or displacer units it is essential that the air is evacuated from the system and a partial vacuum created. Service equipment 18G 703 or 18G 682 must be used for this purpose as follows:

- (6) Remove the pressure valve dust cap and connect the yellow connector to the valve on the sub-frame.
- (7) Close the yellow valve (valve 1) on the service unit.
- (8) Operate the vacuum pump until a reading of 27 in. (68.6 cm.) of mercury is obtained on the

vacuum gauge and all movement of fluid in the tube has stopped. Subtract .5 in. (1.27 cm.) of mercury for every 500 ft. (152 m.) above sea-level.

- (9) Open the yellow valve (valve 1). Wait one or two minutes until any further movement in the tube has stopped and remove the yellow connector.
- (10) Replace the connector plug.

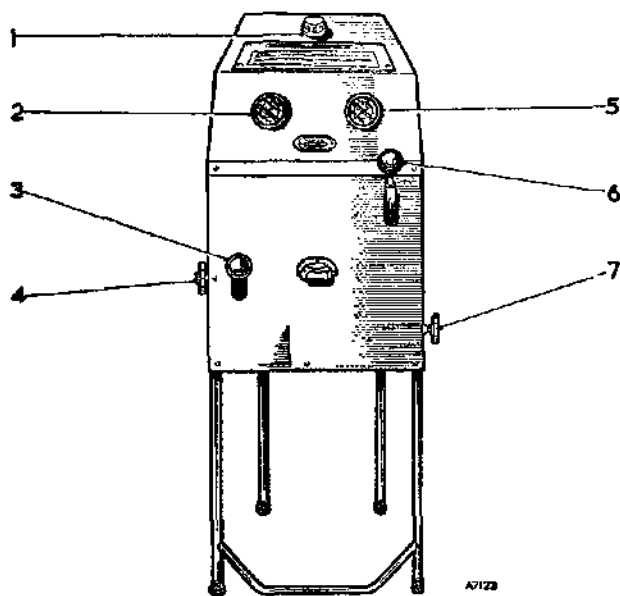

Fig. H.6

The suspension service unit

- | | |
|-----------------------------------|----------------------------|
| 1. Combined vacuum/pressure tank. | 4. Black valve (valve 2). |
| 2. Pressure gauge. | 5. Vacuum gauge. |
| 3. Pressure pump handle. | 6. Vacuum pump handle. |
| | 7. Yellow valve (valve 1). |

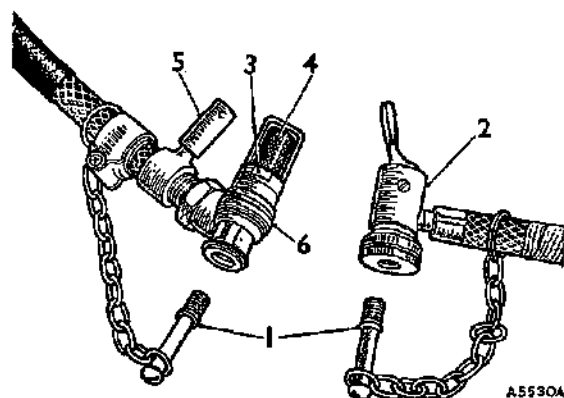

Fig. H.7

The suspension service unit connectors

- | | |
|---|--------------------|
| 1. Sealing plugs. | 4. Knurled knob. |
| 2. Evacuating connector. | 5. Bleeding screw. |
| 3. Depressurizing and pressurizing connector. | 6. Locking slide. |

Pressurizing

Having carried out repairs and evacuated to ensure that all air is out of system, the pressurization should be carried out as follows with the car in the condition given in Section H.9 and resting on all four wheels.

- (11) Connect the servicing unit black connector to the pressure valve on the rear sub-frame with the knurled knob unscrewed.
- (12) Close the black valve (valve 2) and open the bleed valve.
- (13) Operate the pressure pump until air is evacuated from the connecting tube and fluid appears at the bleed valve.
- (14) Close the bleed valve and screw in the knurled knob.
- (15) Increase the pressure until the normal operating pressure is obtained (see 'GENERAL DATA').

If a new displacer unit has been fitted pressurize to 350 lb./sq. in. (24.6 kg./cm.²).

- (16) Unscrew the knurled knob and open the black valve (valve 2) to release the pressure in the connecting pipe.
- (17) Remove the black connector and refit the sealing plug.
- (18) When pressurizing above the normal pressure as item (15), wait 30 minutes to allow the vehicle to settle. Reconnect the black connector with the knurled knob unscrewed, close black valve (valve 2), screw in the knurled knob, open black valve (valve 2) until the normal pressure is shown on the gauge.
- (19) Unscrew the knurled knob, open the black valve (valve 2) to release the pressure in the connecting pipe.
- (20) Remove the black connector, replace the connecting sealing plug and the valve dust cap.

H.6

Servicing unit maintenance

Should the service equipment be used continuously, it may be necessary to carry out the following maintenance.

Service tool 18G 682

- (21) Remove the front panel.
- (22) Remove the drain plug from the vacuum pump, drain the fluid.
- (23) Refill with the recommended vacuum oil S.A.E. 10 through the top of the pump. Replace the plug immediately the fluid commences to flow from the drain hole.
- (24) Lubricate the service unit mechanism periodically.

Service tool 18G 703

- (25) Remove the front panel and fill the vacuum pump with recommended vacuum oil S.A.E. 10 through the filler hole in the top of the pump. Fill only when the level is at the end of its downward stroke.
 - (26) Lubricate the service unit mechanism periodically.
- IMPORTANT.**—When the equipment is not in use both valves should be left open.

Section H.8

DISPLACER UNITS

Removal

- (1) Remove the road wheel and release the helper spring from the radius arm.
- (2) Raise the car and support it beneath the sub-frame member.

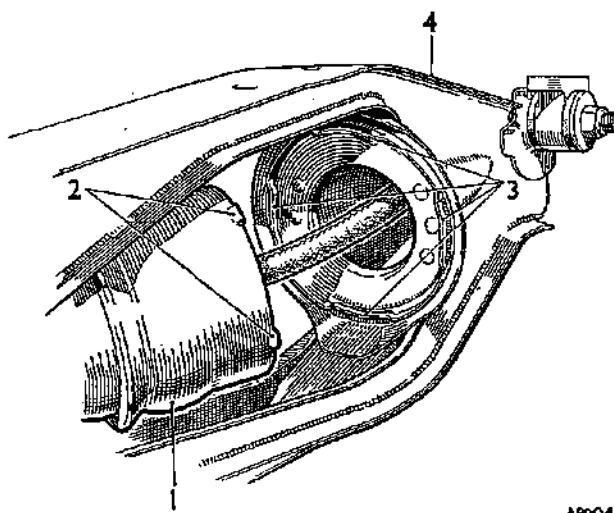

Fig. H.8

A rear displacer unit separated from the locating plate

- | | |
|--------------------|--------------------|
| 1. Displacer unit. | 3. Locating plate. |
| 2. Locating lugs. | 4. Sub-frame. |

- (3) Remove the bump rubber from the sub-frame.
- (4) Depressurize the Hydrolastic system (see Section H.7).
- (5) Disconnect the flexible Hydrolastic hose from its union on the rear face of the sub-frame.
- (6) Remove the displacer strut and turn the unit anti-clockwise and withdraw it from the frame.

Refitting

- (7) Reverse the removal instructions.
- (8) Rotate the displacer clockwise to lock it into the registers on the locating plate.
- (9) Lubricate the strut ball and the nylon seat with Dextragrease G.P. and make sure the dust seal is fitted over the lip of the nylon cup.
- (10) Evacuate and pressurize the system (Section H.7).

Section H.9

SUSPENSION PRESSURE AND WING HEIGHTS

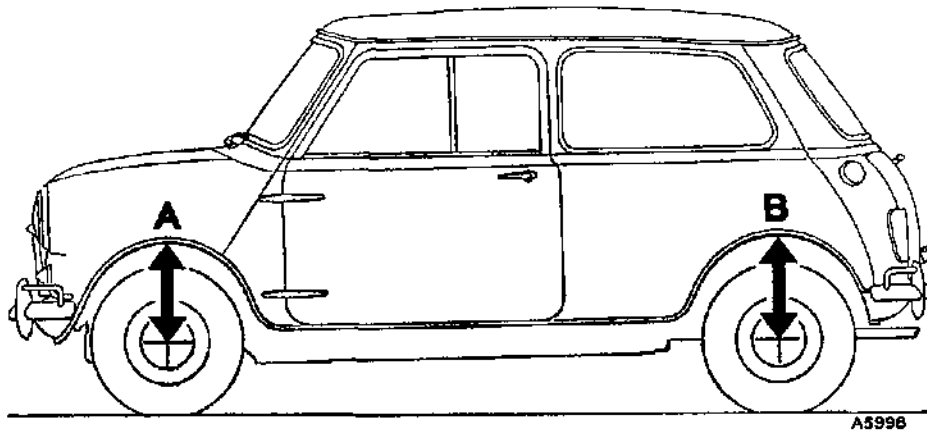

A5998

CONDITION OF CAR

Water; oil; petrol (max.) 4 Imp. gal. (4.8 U.S. gal., 18.2 litres)

| <i>Wing heights (early models)</i> | | <i>Wing heights (later models)</i> | |
|------------------------------------|-----------------------------|------------------------------------|-------------------------------|
| A | B | A | B |
| 13±¼ in. (330±6.35 mm.) | 13½±¼ in. (343±6.35 mm.) | 12¾±¼ in. (320.7±6.35 mm.) | 13¼±¼ in. (333.4±6.35 mm.) |

NOTE.—It is most important that the Hydrolastic suspension system be pressurized to the figures given in 'GENERAL DATA'.

During the initial assembly, or subsequently if a new displacer unit is fitted, the system should be pressurized for a period of 30 minutes to 350 lb./sq. in. (24.6 kg./cm.²) on early models, and to 400 lb./sq. in. (28.1 kg./cm.²) on later models (see chart for commencing car numbers).

On all later cars, modified displacer units, helper springs and rear suspension struts are fitted. These components are not interchangeable individually with those fitted to earlier cars. The suspension pressure is also increased to suit the modified units (see 'GENERAL DATA').

Commencing car numbers:

| <i>Austin</i> | <i>Morris</i> | <i>R.H.D.</i> | <i>L.H.D.</i> |
|---------------|---------------|---------------|---------------|
| Mini | | 830899 | 832055 |
| | Mini | 370004 | 370197 |
| Cooper | | 830061 | 829417 |
| | Cooper | 830127 | 829490 |
| Cooper 'S' | | 820487 | 820514 |
| | Cooper 'S' | 820705 | 820706 |

To check and adjust pressures

- (1) Ensure that the car is resting on all four wheels and that the load condition is as described above.
- (2) Use Service equipment 18G 703 and fit the black connector with the knurled knob unscrewed. Close valve 2 (black valve) and open the bleed valve. Use the pressure pump until air is evacuated from the connection tube and fluid appears. Close the bleed valve, operate the pressure pump until the working pressure is reached (see 'GENERAL DATA'), and then screw in the knurled knob. If the pressure reading is low, operate the pressure pump until the correct working pressure is reached (see 'GENERAL DATA'). If the pressure gauge reading is high, adjust to the correct working pressure by opening valve 2 (black valve). When the pressure reading is correct unscrew the knurled knob, open valve 2 (black valve), and remove the black connector. Replace the sealing plug in the black connector and the pressure dust cap on the suspension unit inter-connecting pipe valve.
- (3) A check can also be made on the suspension pressure, using Service tool 18G 685. The tool must first be adjusted in the following manner. Connect the pump to a pressure gauge fitted with a Schrader valve from which the core has been removed. Fill the tool with Hydrolastic fluid and operate the hand lever of the tool, noting the pressure registered on the gauge. Adjust the valve seat until the working pressure of the system is registered on the gauge (see 'GENERAL DATA'). Tighten the lock screw and replace the washer and screw.

Fit the connector to the suspension unit inter-connecting valve and operate the hand lever until the relief valve in the tool commences to operate. The suspension will now be at its correct working pressure.

Checking wing heights

- (4) Ensure that the load condition is as described above.
- (5) Measure the wing heights as illustrated.

NOTE.—Should the Hydrolastic suspension system suffer damage and the fluid be lost, the suspension arms on the damaged side of the vehicle will contact the bump rubbers at both front and rear. In this condition the car may be driven with complete safety at 30 m.p.h. (50 km.p.h.) over metalled roads.

Section H.10**RADIUS ARMS**
(Hydrolastic Suspension)**Removing**

- (1) Depressurize the Hydrolastic system (see Section H.7).

H.8

- (2) Remove the road wheel and release the helper spring from the radius arm.
- (3) Raise the vehicle and support it beneath the sub-frame side-member.
- (4) Disconnect the brake hose from the radius arm.
- (5) Disconnect the hand brake cable and release the cable sector from the arm.
- (6) Remove the bump rubber from the sub-frame and the end finisher from the sill panel.
- (7) Remove the displacer strut.
- (8) Remove the nut and washers from the arm pivot shaft and the four set screws to release the outer bracket.
- (9) Lift the radius arm assembly away from the vehicle, taking care not to lose the thrust washers and rubber seal fitted between the arm and the sub-frame side-member.

Dismantling is described in Section H.2.

Refitting

- (10) Reverse the removing instructions.
- (11) Lubricate the strut ball end and the nylon seat with Dextragrease Super G.P. and make sure the dust seal is fitted over the lip of the nylon cup.
- (12) Bleed the hydraulic brake system.
- (13) Pressurize the Hydrolastic system (see Section H.7).

Section H.11**SUB-FRAME**
(Hydrolastic Suspension)

Remove and refit the sub-frame as in Section H.1, with the following additional operations:

- (1) Depressurize and evacuate the Hydrolastic system prior to any dismantling, follow the instructions in Section H.7.
- (2) Disconnect both helper springs from the radius arms.
- (3) Disconnect the pressure valves from the sub-frame.
- (4) Evacuate and re-pressurize the Hydrolastic system when reassembly is complete, following the instructions in Section H.7.

Section H.12**SUB-FRAME**
(Moke)

Remove and refit the sub-frame as in Section H.1 with the following exceptions:

Fuel tank and pump removal not necessary.

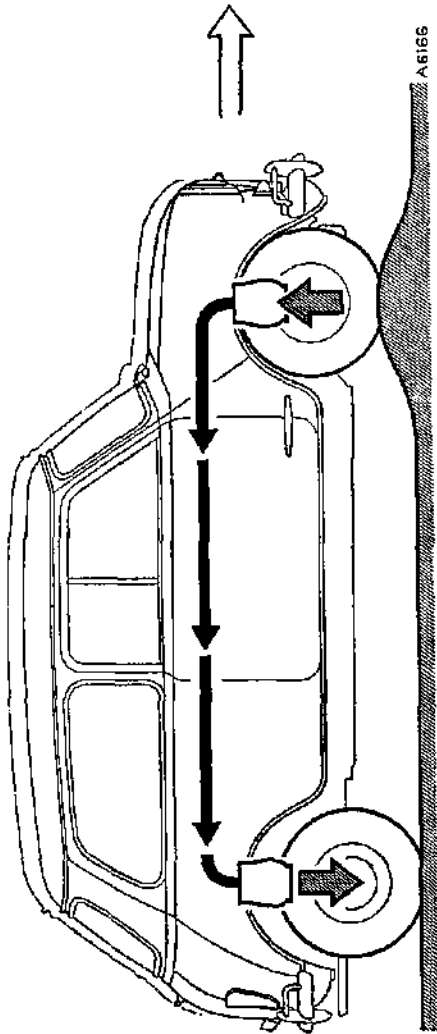

A6166

Fig. H.10
The tail rises in response to upward motion of the front wheel

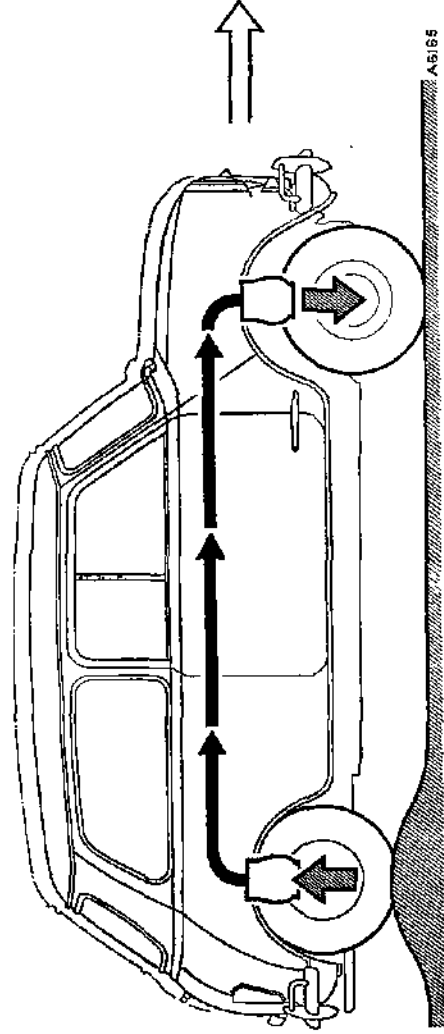

A6165

Fig. H.11
The nose rises in response to upward motion of the rear wheel

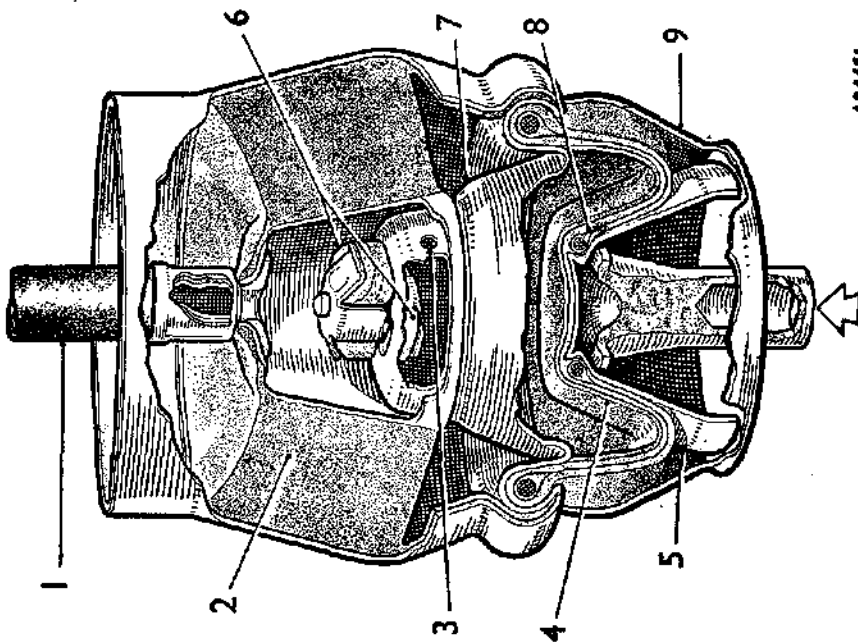

A8446A

Fig. H.9

The Hydrolastic displacer unit

- 1. Interconnecting pipe.
- 2. Rubber spring.
- 3. Damper bleed.
- 4. Butyl liner.
- 5. Tapered piston.
- 6. Damper valve.
- 7. Fluid separating member.
- 8. Rubber diaphragm.
- 9. Tapered cylinder.

Section H.13

RADIUS ARMS (Moke)

Remove and refit as in Section H.2 with the following exceptions:

Fuel tank and pump removal not necessary.

Section H.14

SCHRADER VALVE EXTENSION HOUSING (Hydrolastic Suspension)

To rectify fluid leakage from the Schrader valve extension housing to the pipe elbow:

(1) Depressurize the Hydrolastic system (see Section H.7).

(2) Remove the Schrader valve extension housing from the pipe elbow and clean the threads of both the valve extension housing and the elbow.

(3) The threads of the valve extension housing must be lightly coated with Loctite Grade A after the housing has been re-started on its threads in the elbow. Under no circumstances must Loctite be applied to the valve extension housing before inserting it in the elbow.

(4) Tighten the valve extension housing to a torque of 16 to 20 lb. ft. (2.2 to 2.8 kg. m.) and leave for 24 hours at room temperature before pressurizing the system.

(5) Evacuate and pressurize the system (see Section H.7).

SECTION J**THE STEERING**

| | <i>Section</i> |
|-----------------------------------|----------------|
| Front wheel alignment | J.4 |
| Nylon tie-rod ball ends | J.6 |
| Steering-column | J.2 |
| Steering rack assembly | J.3 |
| Steering-rack lubrication | J.5 |
| Steering-wheel | J.1 |

Section J.1

STEERING-WHEEL

Removal

- (1) Disconnect the battery.
- (2) *Early models.* Withdraw the grub screw in the wheel hub and lift up the horn switch.
- (3) *Mk. II models.* Carefully prise off the wheel hub centre cover.
- (4) Unscrew the wheel retaining nut and pull off the wheel.

Refitting

Reverse the above removing instructions. Tighten the nut to the recommended torque (see 'GENERAL DATA').

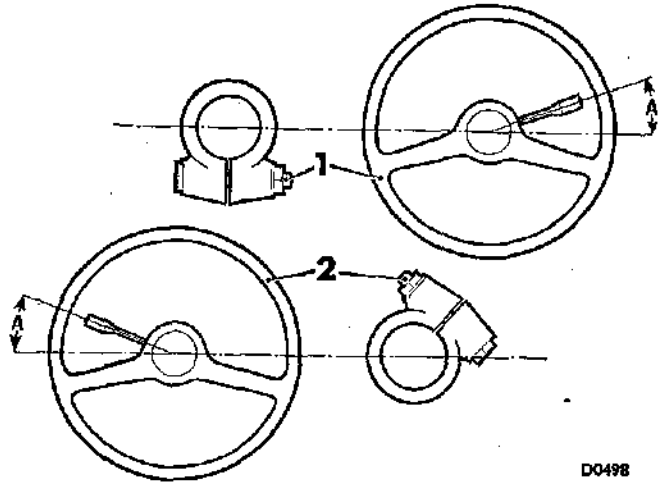

D0498

Fig. J.2

The position of the clamp bolt and direction indicator lever, $A = 20^\circ$

1. Right-hand-drive models. 2. Left-hand-drive models.

Section J.2

STEERING-COLUMN

Removing

- (1) Disconnect the column switch wiring connectors located below the parcel shelf.
- (2) Remove the bolt from the lower column clamp/steering rack pinion shaft.
- (3) Remove the column upper support clamp bolt.
- (4) Mark the fitted position of the outer column with the upper support bracket.
- (5) Pull the column assembly upwards and out of the car.

Dismantling

- (6) Remove the steering-wheel as described in Section J.1.
- (7) Remove both halves of the column cowl.
- (8) Remove the direction indicator switch and screw out the cancelling stud from the column.
- (9) *Early models.* Remove the horn connection slipping assembly.

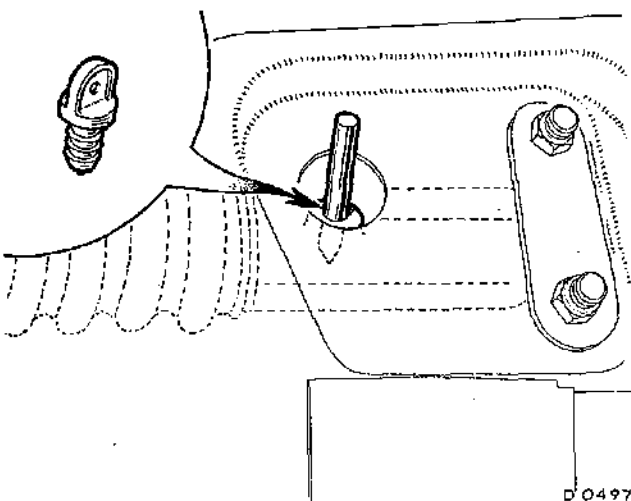

Fig. J.1

Using a locator pin to centralize the rack, with (inset) the plastic plug

- (10) Withdraw the inner column from the lower end of the outer column tube.
- (11) Extract the upper and lower bushes from the outer column tube.

Inspection

- (12) Check the inner column alignment and rectify if required to ensure that when rotated the upper bearing face does not exceed $\frac{1}{8}$ in. (3 mm.) run-out.
- (13) Examine the upper and lower felt bushes and use replacements if necessary. Cylindrical polythene upper bushes are now fitted to all later models.

Reassembling

- (14) Soak the lower felt bush in oil.
- (15) Lubricate the polythene bush with a graphite-based grease and insert it fully into the upper end of the outer column tube.
- (16) Insert the inner column into the outer column, and at the same time roll the lower felt bush around its fitted position on the inner column until both joint faces butt together, then carefully enter the assembly into the outer column.
- (17) Reverse the removing procedure for the other components.
- (18) Before refitting the assembly to the car ensure that the inner column turns freely (see instruction (12)).

Refitting

- (19) Slacken the rack 'U' bolts to allow the rack pinion to align with the column.
- (20) Slacken the column fascia bracket bolts to allow sideways movement.
- (21) Align the road wheels to the straight-ahead position and refit the assembly to the car.
- (22) *Early models.* Engage the marked spline of the pinion shaft with the split portion of the inner column clamp. Push down the assembly until the clamp bolt can be easily inserted. The clamp must be positioned as follows:

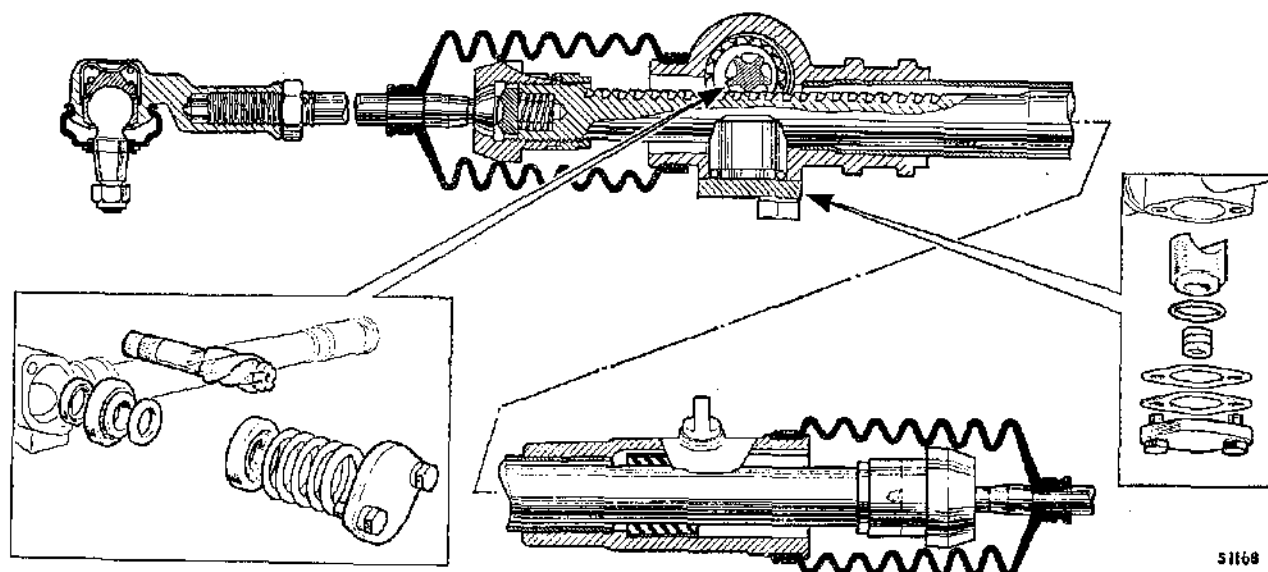

Fig. J.3

A section through the Mk. II steering-rack assembly, with the damper and pinion components shown inset

Left-hand-drive. The clamping bolt axis must be above the steering-column at an angle of 16° to the rack housing.

Right-hand-drive. The clamping bolt axis must be below and parallel to the rack axis.

Tighten the clamping bolt to the correct torque figure (see 'GENERAL DATA').

- (23) *Mk. II models.* Pull out the plastic plug from the rack casing and insert a locator pin, i.e. a ¼ in. (6 mm.) diameter bolt approximately 2 in. (50 mm.) long into the hole. Centralize the rack until the locator pin fully engages in the rack shaft to lock the centralized assembly in position (see Fig. J.1).
- (24) *Mk. II models.* Refit the column onto the pinion with the clamp bolt positioned as shown in Fig. J.2, and tighten to the torque figure given in 'GENERAL DATA'.
- (25) Lift the column and insert the clip into the support bracket, moving the bracket to meet the clip and not vice versa, so that the column remains free of load. Tighten the bracket to fascia rail securing bolts.
- (26) Refit and adjust the indicator trip stud until the combined measurement of the column and the stud is between 1.176 and 1.195 in. (29.87 and 30.35 mm.). Ensure that the longitudinal head of the stud is parallel to the column and tighten the lock-nut. Tighten the column clip to the fascia bracket.
- (27) Ensure that the outer column and direction indicator lever is positioned as shown in Fig. J.2, i.e. with the indicator trip stud exactly between the two cancelling mechanisms of the switch.
- (28) Tighten each of the rack 'U' bolts nuts as a pair, turning each nut alternately a half-turn at a time until secure.
- (29) *Mk. II models.* Remove the locator pin and refit the plastic plug.
- (30) The remainder is a reversal of the removing procedure.

Section J.3

STEERING RACK ASSEMBLY

The rack fitted to the Mk. II models is not interchangeable as a unit or as individual components with those racks fitted to earlier vehicles. Together with the new rack, modified steering levers are fitted and combine to provide the vehicle with a smaller turning circle. Correct wheel alignment is vitally important (see Section J.4).

Removing

- (1) Remove the air cleaner(s).
- (2) Slacken the column clamp bolt.
- (3) Remove the nut, bolt, and spring washer securing the column to the pinion shaft.
- (4) Mark the lower edge of the column shroud at the clamp bracket so that they can be refitted in line.
- (5) Pull the column upwards to free it from the pinion shaft.
- (6) Jack up the front sub-frame and remove the wheels and dampers. Remove the rack ball end retaining nuts and release the ball ends with Service tool 18G 1063.
- (7) Unscrew the four nuts and bolts securing the rear of the sub-frame to the body.
- (8) Remove the four bolts securing the sub-frame towers to the bulkhead cross-member.
- (9) Disconnect the exhaust pipe from the manifold and gear-change extension.
- (10) Disconnect the engine tie-rod.
- (11) Slacken the front sub-frame mounting bolts.
- (12) Remove the nuts from the steering rack 'U' bolts.
- (13) Support the body and remove the jack from the sub-frame; allow the sub-frame to drop and give clearance for the removal of the steering rack.
- (14) *Mk. II models.* Disconnect the remote-control gear lever extension from the floor (see Fig. A.12).

COOPER

Carry out the instructions detailed above and also:

- (15) Disconnect the gear lever extension from the floor.
- (16) Remove the exhaust pipe and silencer (Section A.3).

Dismantling

- (17) Disconnect the tie-rods from the steering-arms.
- (18) Remove the rubber gaiters.
- (19) Remove the damper cover plate, yoke, and spring(s).
- (20) Remove the pinion shaft tail bearing retaining plate, shims, thrust washer, bearing and bearing race, and withdraw the pinion. Extract the top bearing race, bearing, and thrust washer from behind the rack teeth.
- (21) Extract the pinion shaft oil seal.
- (22) Use Service tool 18G 707 to unscrew the ball housing and release the tie-rod, ball seat and tension spring. Remove the second tie-rod.
- (23) Withdraw the rack from the pinion end of the rack housing to obviate damage to the felt or 'Vulkollan' bush fitted in the opposite end of the rack housing.
- (24) Remove the bush securing screw from the rack housing, lever the felt bush at its joint and extract it. The felt bush metal sleeve must be removed if a plastic ('Vulkollan') bush is to be fitted as a replacement for the felt bush.

Inspecting

- (25) Clean all parts and examine for wear, particularly the rack and pinion teeth, and the rubber gaiters. Fit new parts where necessary.

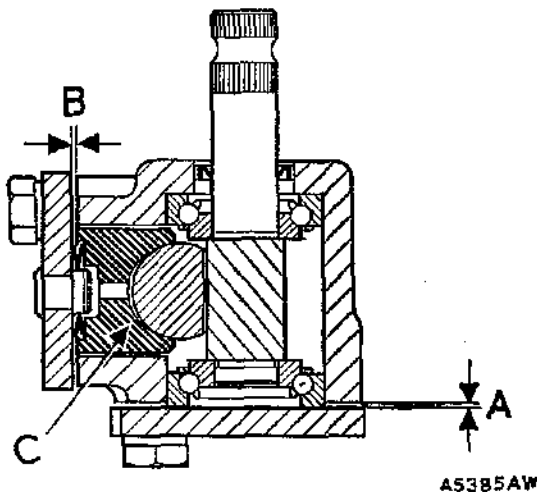

Fig. J.4

A section through the steering pinion and rack damper (1st type)

- A. Take a feeler gauge measurement and fit the pinion end cover with shims to the value of the measurement minus $\cdot 001$ to $\cdot 003$ in. ($\cdot 025$ to $\cdot 076$ mm.) before fitting the damper yoke (c).
- B. Measure the gap and fit shims.
- C. Damper yoke.

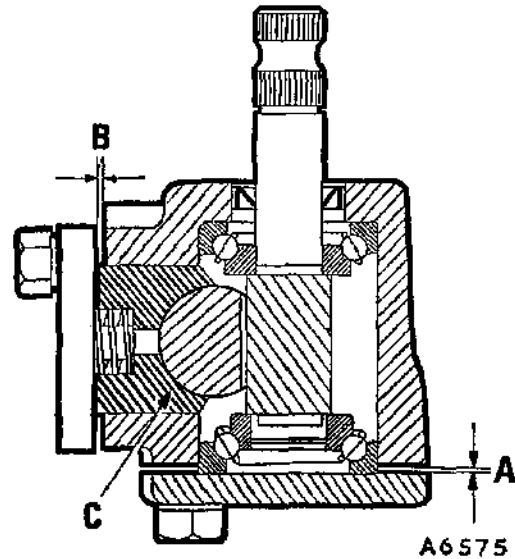

Fig. J.5

A section through the steering pinion and rack damper (2nd type)

- A. Take a feeler gauge measurement and fit the pinion end cover with shims to the value of the measurement minus $\cdot 001$ to $\cdot 003$ in. ($\cdot 025$ to $\cdot 076$ mm.) before fitting the damper yoke (c).
- B. Measure the gap and fit shims.
- C. Damper yoke.

Reassembling

- (26) Reverse the dismantling sequence but note: If fitting a new felt bush (early models), soak the bush in E.P. S.A.E. 140 oil.
- (27) The plastic bush may be used as a replacement for the felt bush and is used together with a steel sleeved bush and spacer. Insert the spacer (plain end first) into the rack housing. Fit the plastic bush into the steel sleeve and insert it into the rack housing (plain end first), with the flats on the plastic bush positioned offset to the retaining screw hole in the rack housing. Ensure that the spacer and bush are correctly positioned and drill through the retaining screw hole and the bush with a $\frac{1}{8}$ in. ($\cdot 27$ mm.) drill. Remove all swarf; coat the retaining screw with a jointing compound and refit to secure the bush. Check that the screw does not project into the bore of the plastic bush.
- (28) *Pinion adjustment (early models)*. Refit the cover without the shims, but do not over-tighten the screws. Measure the gap between the cover and the housing. Remove the cover and add shims to the thickness of the measurement minus $\cdot 002$ in. ($\cdot 05$ mm.). Refit the cover with jointing compound.
- (29) *Pinion adjustment (Mk. II models)*. Refit the pinion and bearings as shown in Fig. J.3. Add sufficient shims together with the spacer washer to provide a clearance of approximately $\cdot 010$ in. ($\cdot 25$ mm.) between the rack housing and the cover plate. Fit and lightly tighten the cover plate. Take a feeler gauge measurement of the clearance (A) and reduce the shimming by the measurement taken,

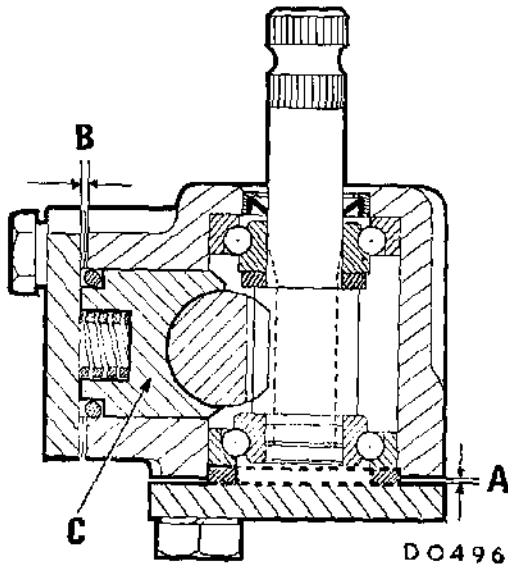

Fig. J.6

A section through the steering pinion and rack damper (Mk. II models)

- A. Take a feeler gauge measurement and fit the pinion end cover with shims to the value of the measurement minus .002 to .005 in. (.05 to .13 mm.) before fitting the damper yoke (c).
- B. Measure the gap and fit shims.
- C. Damper yoke.

less .002 to .005 in. (.05 to .13 mm.), to give the required pre-load.

- (30) Refers to item (22). Screw the ball housing locking ring onto the rack end as far as it will go and refit the lock washer. On models not fitted with a lock washer, fit a new locking ring. Refit the seat spring, seat, tie-rod and ball housing, and tighten up until the tie-rod is pinched. Slacken the housing one-eighth of a turn and tighten the locking ring to the recommended torque. Punch the lock washer into the slots of the housing and locking ring. If no lock washer is fitted, punch the lips of the locking ring into the slots of the ball housing and rack.
- (31) *Damper adjustment (1st type)*. Refit the yoke with the disc springs but without the packing shims.

With the rack in the straight-ahead position, tighten the cover screws until it is just possible to rotate the pinion with the pre-load gauge, 18G 207 and 18G 207 A set at 15 lb. in. (.17 kg. m.). Measure the gap between the damper housing flange and the rack housing. Remove, and then refit the damper with shims to the thickness of the measurement minus .002 in. (.05 mm.).

- (32) *Damper adjustment (2nd type and Mk. II models)*. Refit the yoke and cover plate without the spring.

Follow the measurement checking procedure given in item (31) and refit the yoke with its 'O' ring seal (Mk. II models), together with the spring and cover plate, with shims to the value of the measurement plus .002 in. to .005 in. (.05 to .13 mm.).

- (33) Refit the rubber gaiters to the housing and the tie-rods. Before securing the gaiter clip on the tie-rod

at the pinion end, stand the assembly upright and pour in approximately $\frac{1}{2}$ pint (.4 U.S. pint, .19 litre) of Extreme Pressure S.A.E. 90 oil through the end of the gaiter. Refit and tighten the gaiter clip.

- (34) Check that the tie-rods have an equal number of threads visible behind each locknut, i.e. approximately eight threads on early racks and 11 threads on the Mk. II racks.
- (35) *Early models*. Centralize the rack in the housing. The full travel of the rack in each direction is 1.75 in. (44.5 mm.).

Refitting

ALL MODELS

Reverse the removal instructions, but note:

- (36) Refit the rack to the body with the 'U' bolts lightly tightened to allow the pinion to accept the column alignment.
- (37) Align the road wheels to the straight-ahead position.
- (38) Carry out the operations (20), and (22) to (30) in Section J.2.
- (39) Check and reset the wheel alignment (see Section J.4).

Section J.4

FRONT WHEEL ALIGNMENT

Checking

When checking or adjusting the front wheel alignment it is essential to use equipment designed to work at the specified height and diameter, and preferably a gauge which measures the angles involved rather than the difference in distance between the wheels in front of and behind the centres.

With the car unladen, tyres at the correct pressures, and the steering in the straight-ahead position, each wheel should make an angle of 7° 30' with the longitudinal axis

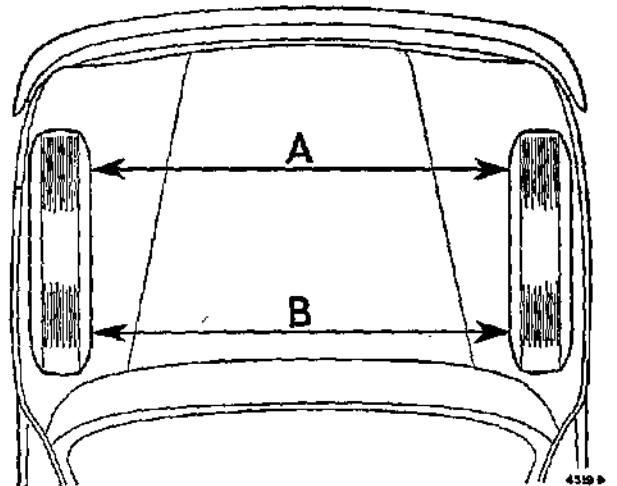

Fig J.7

The front wheel alignment check must be taken with the front wheels in the straight-ahead position. Dimension (A) must be $\frac{1}{16}$ in. (1.6 mm.) greater than (B)

of the car. When this angle is correct the distance between the front of the wheels will be $\frac{1}{8}$ in. (1.6 mm.) greater than that at the rear (see Fig. J.7).

When measuring distances rather than angles the measurements must be made on a $1\frac{1}{2}$ in. (368.3 mm.) diameter on the side wall of the tyre at a distance of 9.4 in. (239 mm.) above the ground.

If a base-bar alignment gauge is used, take two measurements; take a measurement at the front, mark the point on the tyres with chalk, push the car forward half a road wheel revolution and take the second measurement at the same points on the tyres and behind the centres.

With an optical gauge, take two readings with the car moved forward 180° and three with it moved forward 120° . The average figure should then be calculated.

Adjustment (Early models)

To adjust the track, slacken the tie-rod ball joint locknuts and the rubber gaiter clips, and turn each tie-rod the same number of turns until the adjustment is correct.

The tie-rods must be exactly the same length.

MK. II MODELS

The later steering-rack provides a smaller turning circle and it is vitally important that the wheel alignment is checked, and adjusted if necessary, following the correct procedure. Incorrect adjustment could result in excess articulation of the drive shaft constant velocity joints, and subsequent fouling of the suspension tie-rods by the road wheels when on full lock. Checking and adjustment must only be carried out when the vehicle is at 'kerbside' trim, i.e. fully equipped but without occupants or excess luggage.

Checking

- (1) With the vehicle resting on its wheels, turn the steering on each lock and check the clearance between the road wheel and the suspension tie-rod. The minimum clearance should not be less than $\frac{1}{2}$ in. (19 mm.), or with the suspension at full rebound, not less than $\frac{1}{4}$ in. (6.5 mm.).

Correct adjustment on each tie-rod will be indicated by the clearance figures given above being approximately the same on each side. Check the wheel alignment with an optical gauge, see item (6).

Adjustment

- (2) Slacken the rack tie-rod locknuts and the gaiter clips. Disconnect the ball joints from the steering levers, using Service tool I8G 1063.
- (3) Lift the floor covering and remove the rubber grommet from the floor panel (opposite side to the rack pinion).
- (4) Pull out the plastic plug from the rack body and insert a locator pin, i.e. $\frac{1}{8}$ in. (6 mm.) diameter bolt into the hole (see Fig. J.1).

- (5) Centralize the rack until the locator pin fully engages with the rack, to lock the centralized assembly.
- (6) Use an optical setting gauge and align the road wheels to the straight-ahead position, i.e. $\frac{1}{8}$ in. (1.6 mm.) toe out, and in alignment with the centre line of the car.
- (7) Adjust the tie-rods until each ball pin will correctly locate its steering lever without disturbing the alignment given in item (6), and secure in position.
- (8) Recheck the setting and adjust equally each tie-rod until the setting is obtained and tighten the locknuts. Ensure that the rubber gaiters are not under stress from twist and tighten the securing clips.
- (9) Remove the locator pin and refit the plastic plug.
- (10) Recheck the adjustment as detailed in item (1).
- (11) Refit the floor grommet and covering.

NOTE.—The hole in the rack from which the plastic plug was removed **MUST NOT** be utilized for the purpose of 'topping up' with lubricant.

Section J.5

STEERING RACK LUBRICATION

Lubricating nipples are not provided and rack lubrication is only necessary if leakage is evident from the rack housing or the rubber gaiters.

The following procedure should be followed provided the leakage can be rectified without the assembly being removed.

- (1) Centralize the steering rack.
- (2) Remove the gaiter retaining clip on the driver's side.
- (3) Inject $\frac{1}{2}$ pint (2 litre) of E.P. S.A.E. 90 oil into the rubber gaiter.
- (4) Refit the gaiter clip and turn the steering from side to side to distribute the oil through the housing.

WARNING.—If the vehicle is hoisted with its front wheels clear of the ground care should be taken to avoid forceful movement of the wheels from lock to lock, otherwise damage may occur within the steering mechanism.

Section J.6

NYLON TIE-ROD BALL ENDS

Later ball joints have nylon seats sealed for life and protected by rubber boots; no lubrication is required.

The rubber boots must be maintained in good condition, and if it is found that a boot has become damaged in service both boot and joint must be renewed. However, if a boot is damaged in the workshop during the removal of a joint which has therefore not become contaminated by road dirt, the boot alone may be renewed.

Before fitting a new boot smear the area adjacent to the joint with a little Dextragrease Super G.P. lubricant.

SECTION K

THE FRONT SUSPENSION

| | <i>Section</i> |
|--|----------------|
| Hydrolastic suspension | |
| Description | H.6 |
| Depressurizing, evacuating, pressurizing | H.7 |
| Displacer units | K.7 |
| Upper suspension arms | K.8 |
| Rubber suspension | |
| Lower arm | K.5 |
| Spring units | K.1 |
| Struts | K.6 |
| Upper arm | K.4 |
| Swivel hub ball joints | K.3 |
| Swivel hub outer oil seal | K.9 |
| Swivel hubs | K.2 |

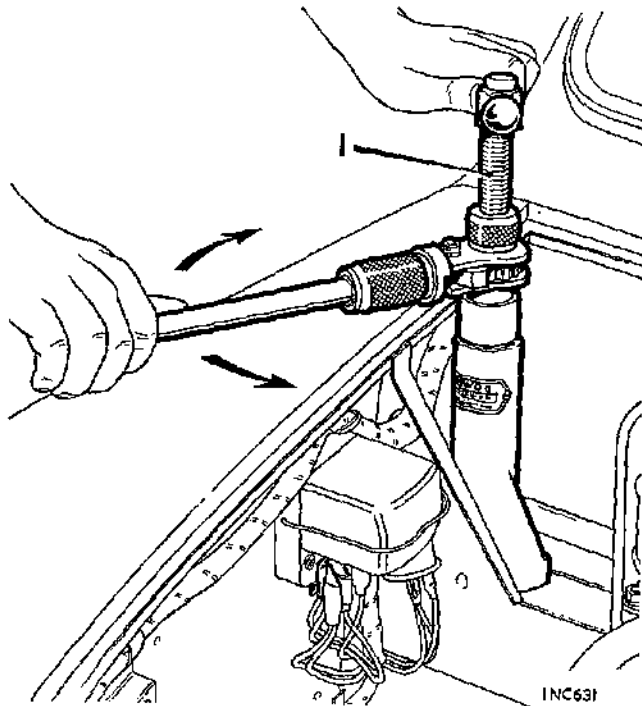

● Fig. K.1

Compressing the spring unit

1. Service tool 18G 574 B ●

Section K.1
SPRING UNITS
 (Rubber Suspension)
Compressing

- (1) Slacken one bolt (or nut) and remove the other securing the sub-frame towers to the engine bulk-head cross-member.
- (2) Move the locking plate to one side to expose the access hole in the cross-member. Refit the bolt (or nut) and tighten both.
- (3) Insert Service tool 18G 574 B through the cross-member, locate the body of the tool over the two sub-frame bolts (or nuts), and screw the centre of the tool nine complete turns into the spring unit. Use the ratchet handle to turn the centre nut and make contact with the body of the tool. Hold the centre screw to prevent further rotation and then turn the ratchet handle clockwise to compress the spring sufficiently to allow removal of the spring strut from the tower. Do not over-compress the spring.

Removing

- (4) Jack up the car after compressing the spring, and remove the road wheel.
- (5) Remove the bump rubber from the tower.
- (6) Remove the retaining nut and release the upper suspension arm with Service tool 18G 1063.

- (7) With the spring unit compressed, lever the strut from the spring unit, see Fig. K.4.
- (8) Detach the hydraulic damper, dismantle the upper arm pivot and remove the upper arm.
- (9) Hold the centre screw of the tool to prevent it turning, screw the ratchet handle upwards to release the spring compression, remove the tool, and extract the spring unit from the tower.

Refitting

- (10) Reverse the removing instructions.

Section K.2**SWIVEL HUBS****Removing**

- (1) Jack up the front of the vehicle, place supports under the sub-frame and remove the road wheel.
- (2) Remove the steering lever ball joint retaining nut and release the ball joint using Service tool 18G 1063.
- (3) Mark the drive shaft flange for correct reassembly and disconnect the inner flexible joint by removing the four outer 'U' bolts.
On models which have a universal joint flange, remove the four retaining nuts.
- (4) Slacken the front brake pipe union from its hose connection and unscrew the nut securing the hose to the anchor bracket. Unscrew the hose from the backplate (it will still remain attached to the anchor bracket and pipe union).
Disc brake models. Remove the brake calliper and support it; do not allow it to hang on the hydraulic hose.
- (5) Disconnect the tie-rod from the lower suspension arm.
- (6) Remove the upper and lower swivel hub ball pin retaining nuts and release the ball pins from the suspension arms using Service tool 18G 1063.
- (7) Withdraw the swivel hub and drive shaft from the vehicle.

Dismantling

- (8) Remove the brake-drum (except disc brake models).
- (9) Extract the split pin and remove the nut, and distance washer (outer taper collar on Disc brake models).
- (10) Drift the drive shaft from the flange and hub. Drift the driving flange from the hub using Service tool 18G 575.
Disc brake models. Tap the end of the drive shaft with a hide mallet and pull off the driving flange and disc assembly. Remove the drive shaft, the inner and outer bearing and distance ring from the hub.
- (11) Remove the bearing to flange distance piece and outer seal, the inner seal with water shield (if fitted) and spacer.

●Fig. K.2

The swivel hub assembly

(Mini range with front drum brakes)

1. Drive shaft nut.
2. Driving flange.
3. Distance piece.
4. Brake-drum.
5. Hub assembly.
6. Hub bearings.
7. Bearing distance ring.
8. Outer seal oil.
9. Spacer for oil seal.
10. Inner oil seal.
11. Water shield.
12. Drive shaft. ●

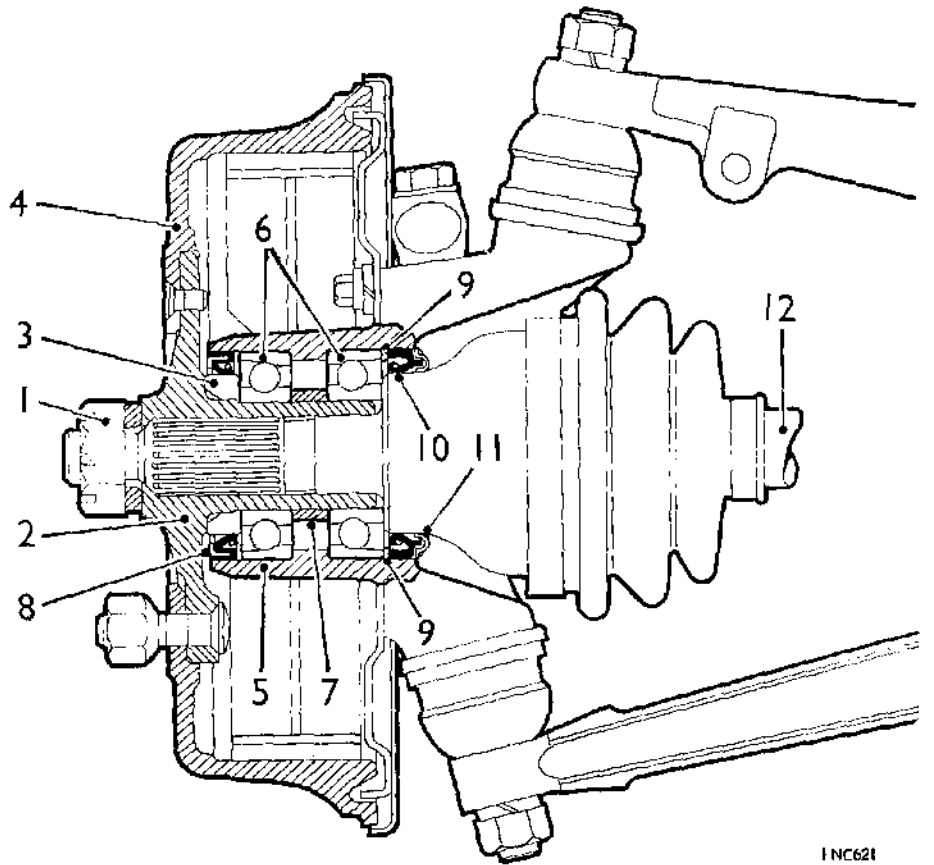

INC621

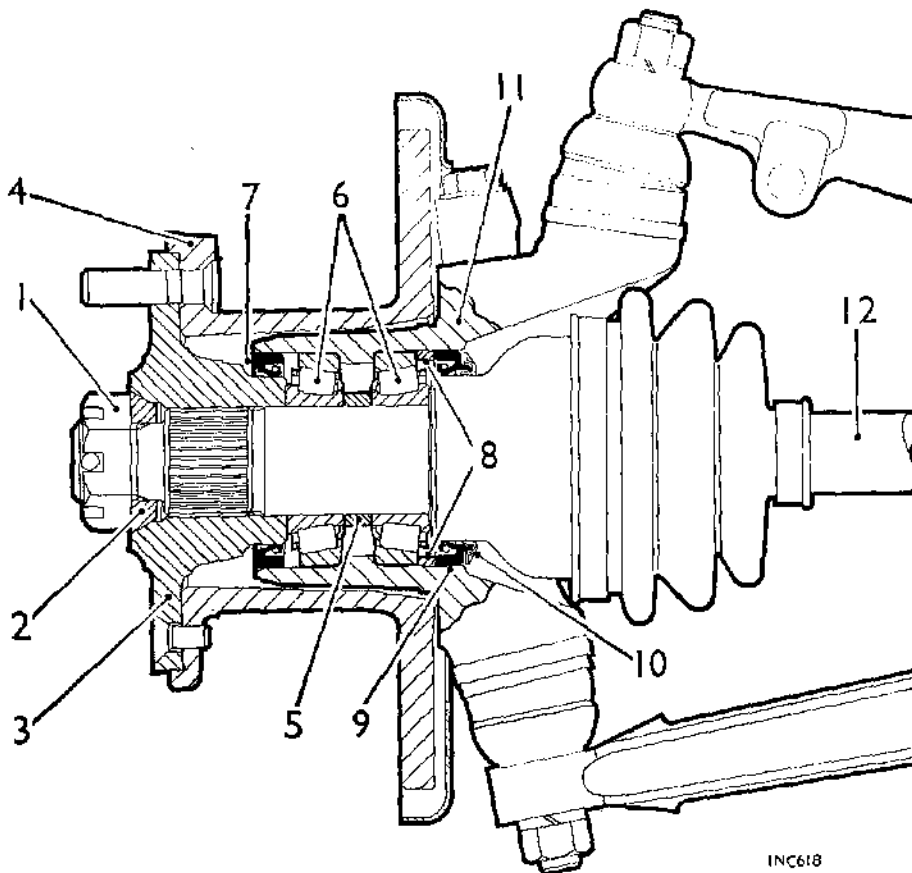

Fig. K.3

●*The swivel hub assembly*

(Cooper 'S' and 1275 GT)

1. Drive shaft nut.
2. Outer tapered collar.
3. Driving flange.
4. Hub and disc assembly.
5. Bearing distance ring.
6. Taper roller bearings.
7. Outer oil seal.
8. Spacer (inner bearing to seal).
9. Inner oil seal.
10. Water shield.
11. Swivel hub.
12. Drive shaft. ●

INC618

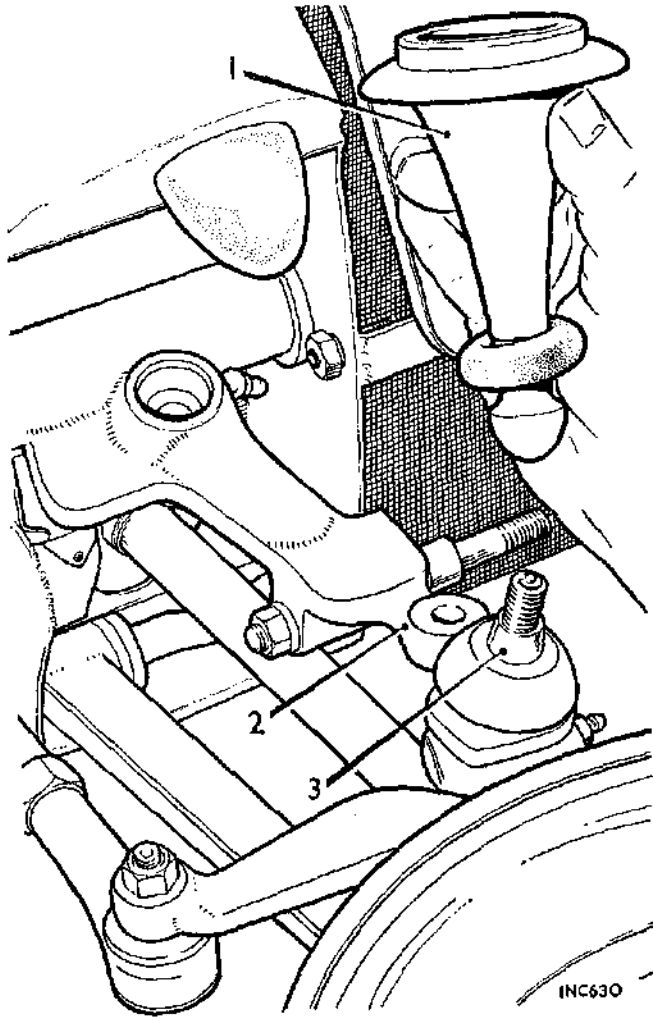

● Fig. K.4

Removing the spring strut (1) with the spring unit compressed and the upper support arm (2) removed from the hub ball pin (3) ●

(12) Drift out the inner race of each bearing and remove the distance ring. Use Service tool 18G 260 H to withdraw the outer races.

(13) **Disc brake models.** Substitute for operations (11) and (12). Remove the outer seal and the inner seal with water shield (if fitted), drive out the inner and outer bearing cups with a brass drift, note that the hub has recesses for this but take care not to damage the hub bore.

Reassembling

(14) Reassembling is a reversal of the dismantling procedure but note the following points:

(a) Pack the bearings only with a high-melting point grease, e.g. (Duckhams L.B.10).

(b) When refitting 'thrust type' bearings, ensure that the sides marked 'THRUST' are facing each other, with the distance ring between them.

(c) When replacing the inner oil seal, ensure that the later type single lipped seal together with its plastic water shield is used. This seal and water shield must be fitted as a pair and replaces all seals previously used for the various models.

(d) Use Service tool 18G 134 and adaptor 18G 134 DO to fit both new seals to the hub. Ensure that the water shield is fitted to the drive shaft as shown in Fig. K.5.

Refitting

(15) Reverse the removing procedure noting the following points:

(a) Tighten the ball pin retaining nuts to the torque figure given in 'GENERAL DATA'.

(b) Tighten the drive shaft nut to the correct torque figure, see 'GENERAL DATA' for the particular model application.

(c) **Disc brake models.** Check the run-out on the periphery of the disc. If this exceeds .006 in. (.15 mm.) reposition the driving flange assembly on the drive shaft splines until the run-out is within this limit.

(d) Use a new split pin to lock the drive shaft nut, refit the brake drum or calliper as applicable.

(e) Bleed the braking system (Section M.8) if the brake pipe has been disconnected. ●

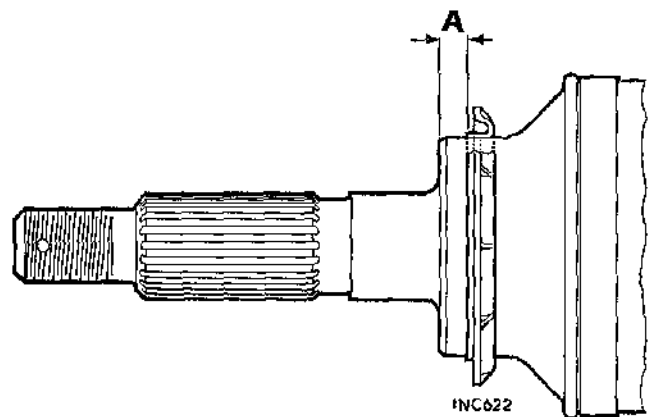

● Fig. K.5

The fitted location of the water shield on the drive shaft before the hub is refitted

'A' = $\frac{1}{4}$ in. (6.4 mm.) ●

Section K.3

SWIVEL HUB BALL JOINTS

Removing

- (1) Compress the rubber spring unit as detailed in Section K.1 or depressurize the Hydrolastic system, see Section H.7.
- (2) Carry out operations (1), (2) and (4) in Section K.2.
- (3) Fit Service tool 18G 304 with adaptor bolts 18G 304 F to the wheel hub studs, ensure that the swivel hub is free of the upper and lower suspension arms and extract the hub from the drive shaft.

Dismantling

- (4) Remove the Service tool and secure the swivel hub assembly firmly in a vice.
- (5) Remove the ball housing dust seal and lubricator.
- (6) Tap back the lock washer and unscrew the upper ball pin retainer using Service tool 18G 587.
- (7) Repeat operation (6) on the lower ball joint noting the spring fitted under the ball pin seat.
- (8) Clean and examine the components and fit replacements as necessary.

Adjusting

- (9) Reassemble the upper ball pin assembly; refit the ball pin seat, pin and retainer without the packing shims and locking washer.
- (10) Screw down the ball pin retainer until there is no free movement between the ball pin and its seating. Measure the gap between the retainer and the swivel hub, see Fig. K.6.
- (11) Note that the thickness of a new locking washer is .036 in (.9 mm.); deduct this figure from the gap measurement taken in operation (10) to obtain the correct thickness of shims required. The final assembly must have no nip to .003 in (.7 mm.) end-float, add a further shim if necessary to obtain the correct adjustment.
- (12) Pack the joint with grease and refit the assembly complete with shims and a new locking washer to the hub.
- (13) Tighten the ball pin retainer with Service tool 18G 372 and adaptor 18G 587 to the torque figure given in 'GENERAL DATA'.
- (14) Repeat operations (9) to (13) for the lower ball pin, except that the spring fitted in the lower assembly must be removed when taking the gap measurement as detailed in operation (10) and refitted under the ball pin seating on final assembly.
- (15) Tap up the locking washer against three flats of the ball pin retainer, (one flat must be adjacent to the brake disc on disc brake models).
- (16) Fit new ball pin dust seals if required.

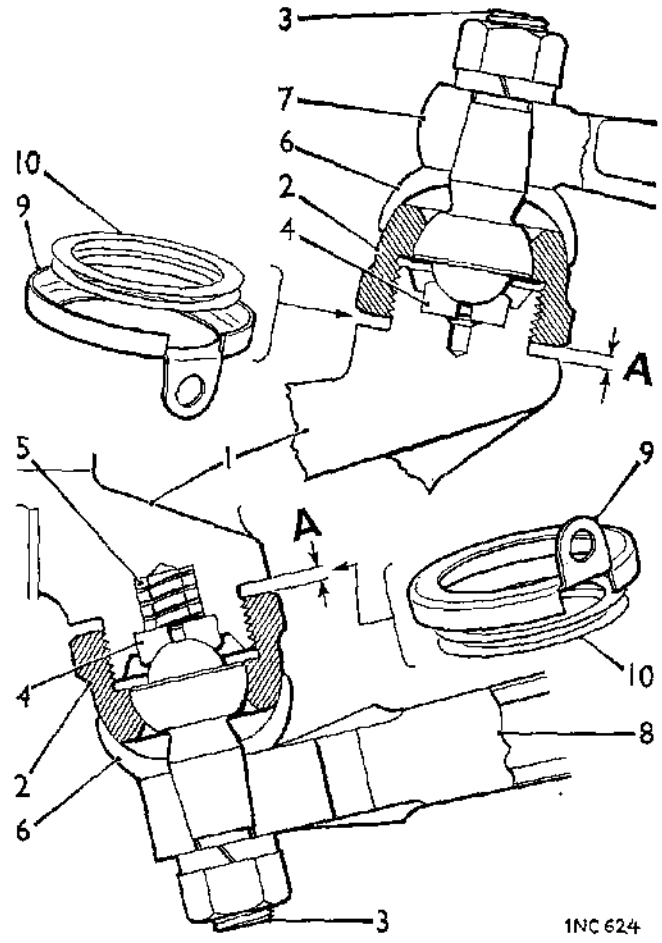

●Fig. K.6

1NC 624

A section through the swivel hub ball joints. 'A' indicates the gap measured for shim adjustment

- 1. Hub assembly.
 - 2. Ball pin retainer.
 - 3. Ball pin.
 - 4. Ball pin seat.
 - 5. Seat spring (lower assembly only).
 - 6. Dust seal.
 - 7. Suspension upper arm.
 - 8. Suspension lower arm.
 - 9. Locking washer
 - 10. Shims
- } fitted on final assembly. ●

Refitting

- (17) Refitting is a reversal of the removing procedure, tighten the upper and lower ball pin nuts to the torque figure given in 'GENERAL DATA'.
- (18) Tighten the drive shaft nut to the correct torque figure, see 'GENERAL DATA' for the particular model application.
- (19) Release the rubber spring unit from compression as detailed in Section K.1, operation (9); or pressurize the Hydrolastic system as detailed in Section H.7.
- (20) Tighten the brake pipe connection and bleed the braking system (Section M.8).
- (21) Disc brake models. Refit the brake calliper.
- (22) Refit the road wheel and lower the car. ●

Section K.4

UPPER ARM
(Rubber Suspension)

Removing

- (1) Compress the spring as in Section K.1.
- (2) Jack up the vehicle and remove the road wheel and damper.
- (3) Remove the ball-pin retaining nut, release the upper suspension arm with Service tool 18G 1063 and withdraw the strut, see Fig. K.4.
- (4) Remove the nut and washer from each end of the shaft.
- (5) Remove the front thrust collar retaining plate, the collar and the seal and push the shaft forward.
- (6) Remove the rear thrust washer and seal and manoeuvre the arm from the frame.
- (7) Extract the needle-roller bearings from the arm with Service tool 18G 581.

Refitting

Reverse the removing instructions, but note:

- (8) Lubricate all parts with grease.
- (9) Fit the needle-roller bearings with the marked ends outwards, using Service tool 18G 582 and adaptor 18G 582 A to push them into position.
- (10) Lubricate the spring unit strut nylon cup with Dextragrease Super G.P.

Section K.5

LOWER ARM

Removing

- (1) Jack up and remove the road wheel and damper.
- (2) Support the suspension with a jack under the brake-drum.
- (3) Disconnect the tie-rod from the lower arm.
- (4) Release the lower arm from the swivel hub with Service tool 18G 1063.
- (5) Remove the nut and washer from the rear end of the shaft and withdraw the shaft.

●NOTE.—Later vehicles are fitted with modified lower arms and these are fitted with composite steel/rubber bushes. These new parts can be fitted to earlier vehicles but only as complete sets.

- (6) Refitting is a reversal of the removing instructions but note the following:

Tighten the shaft securing nut when the vehicle is resting on the road wheels—to prevent pre-loading of the rubber bushes. ●

K.6

Section K.6

SUSPENSION STRUTS
(Rubber Suspension)

Some cars have been fitted with struts having a circular-section washer between the body of the suspension strut and the knuckle end. When fitting a new strut to these vehicles, make sure the washer is included.

Section K.7

DISPLACER UNITS
(Hydrostatic Suspension)

Removing

- (1) Jack up the car and remove the road wheel.
- (2) Depressurize and evacuate the Hydrostatic system (see Section H.7).
- (3) Release the displacer strut dust seal from the nylon seat and extract the strut from the displacer unit.
- (4) Disconnect the displacer hose from the union on the engine bulkhead.

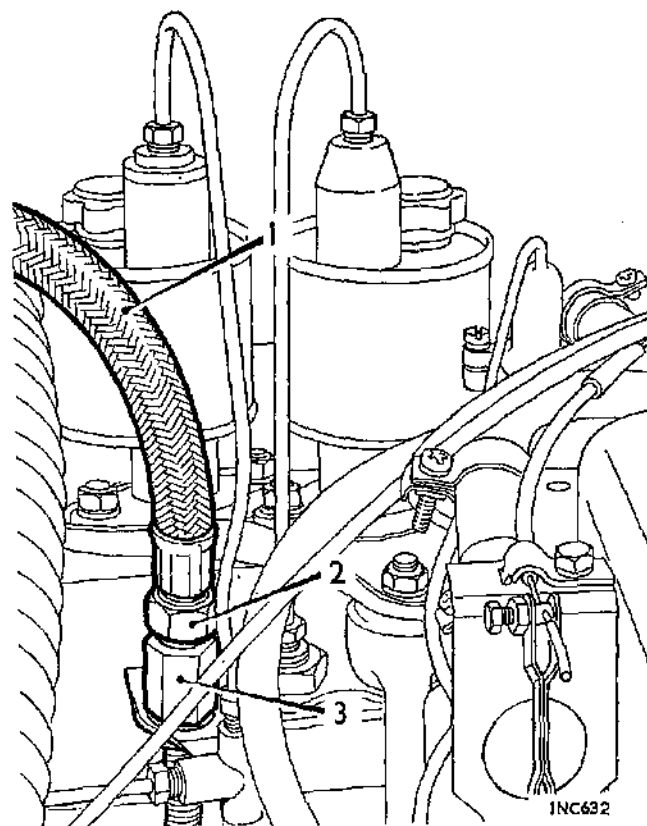

●Fig. K.7●

The right-hand front displacer hose connector

1. Displacer hose.
2. Hose nut.
3. Connector.

- (5) Remove the suspension upper arm (see Section K.4).
- (6) Push the displacer upwards and remove two screws to release the displacer bracket from inside the sub-frame tower.
- (7) Rotate the displacer anti-clockwise and withdraw it from the sub-frame.

Refitting

- (8) Reverse the removing instructions.
- (9) Rotate the displacer clockwise to lock it into the registers on the locating plate.
- (10) Lubricate the strut ball end and the nylon seat with Dextragrease Super G.P. and make sure the dust seal is fitted over the lip of the nylon cup.
- (11) Evacuate and pressurize the system (see Section H.7).

Section K.8

**UPPER SUSPENSION ARMS
(Hydrolastic Suspension)**

Removal

Depressurize the Hydrolastic system as in Section H.7 and follow the instruction in K.4 for arm removal.

Section K.9

SWIVEL HUB OUTER OIL SEAL

The following instructions will permit a leaking outer seal to be replaced when the driving flange is removed.

NOTE.—A bearing overhaul will still require swivel hub removal as in Section K.2.

Removing

- (1) Remove the hub cover, extract the split pin, and slacken the drive shaft nut.
- (2) Slacken the wheel nuts and jack up the vehicle.
- (3) Take off the road wheel and remove the brake-drum.
- (4) Remove the drive shaft nut and assemble the Service tool 18G 304 and 18G 304 F to the drive flange.
- (5) Replace the Service tool centre screw with adaptor 18G 304 P and use the impulse extractor 18G 284 to remove the flange.
- (6) Should the outer bearing inner race come away with the driving flange, it can be removed with Service tool 18G 705 and adaptor 18G 705 B.

Refitting

- (7) Refit the inner bearing race (if extracted).
- (8) Fit the new seal and apply a suitable amount of lubricant to the lip to prevent burning.
- (9) Insert the outer bearing distance piece into the seal with the chamfered bore to the outside.
- (10) Assemble the drive flange to the hub, drifting it into position gently, turning the flange 180 degrees several times to align the bearing distance piece with the flange boss.
- (11) Refit the brake-drum.
- (12) Refit the drive shaft washer, chamfered bore facing inward and refit the nut.
- (13) Tighten the drive shaft nut to the torque figure given in 'GENERAL DATA' and secure with the split pin.

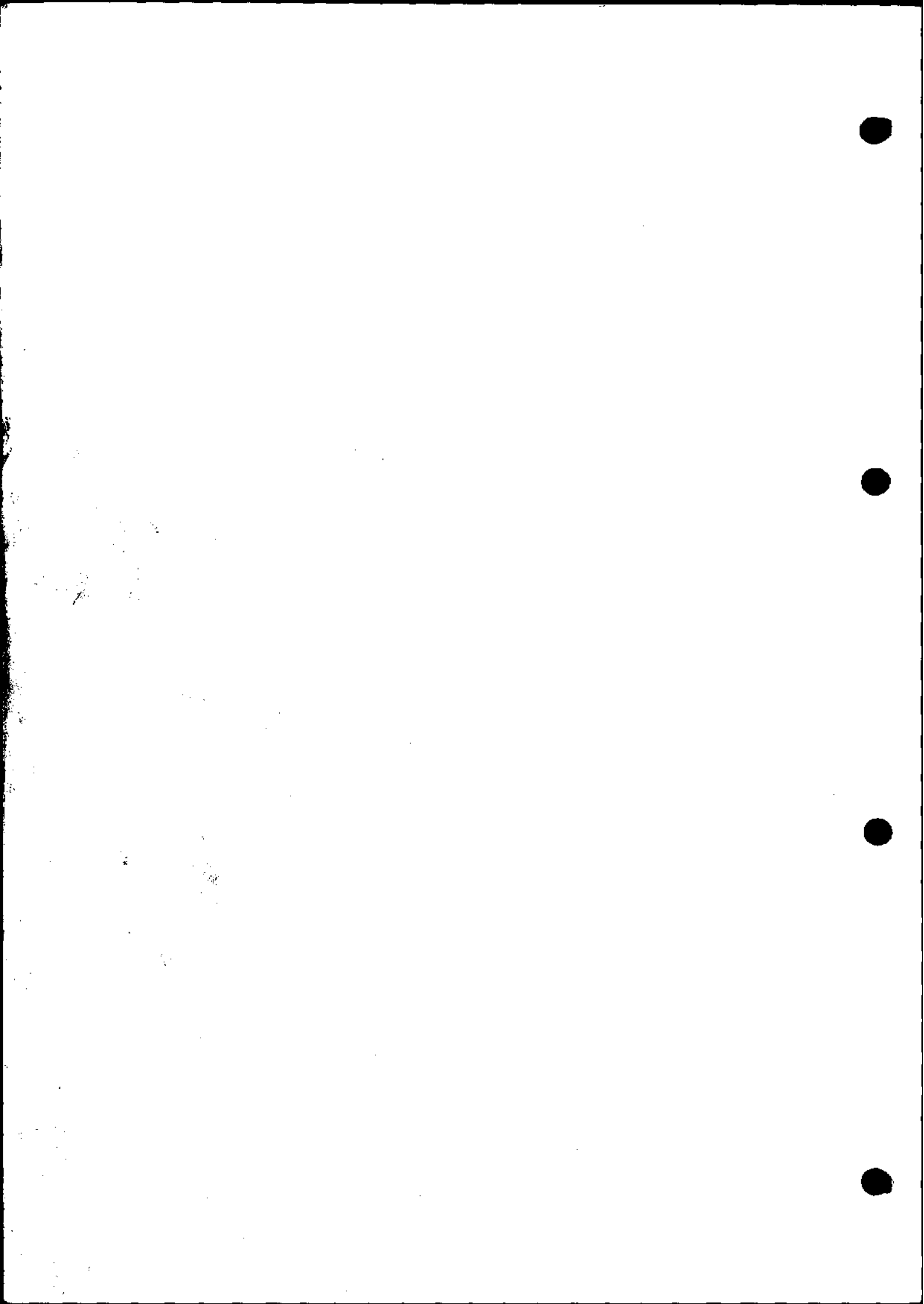

SECTION K

THE FRONT SUSPENSION

| | <i>Section</i> |
|--|----------------|
| Hydrolastic suspension | |
| Description | H.6 |
| Depressurizing, evacuating, pressurizing | H.7 |
| Displacer units | K.7 |
| Upper suspension arms | K.8 |
| Rubber suspension | |
| Lower arm | K.5 |
| Spring units | K.1 |
| Struts | K.6 |
| Upper arm | K.4 |
| Swivel hub ball joints | K.3 |
| Swivel hub outer oil seal | K.9 |
| Swivel hubs | K.2 |

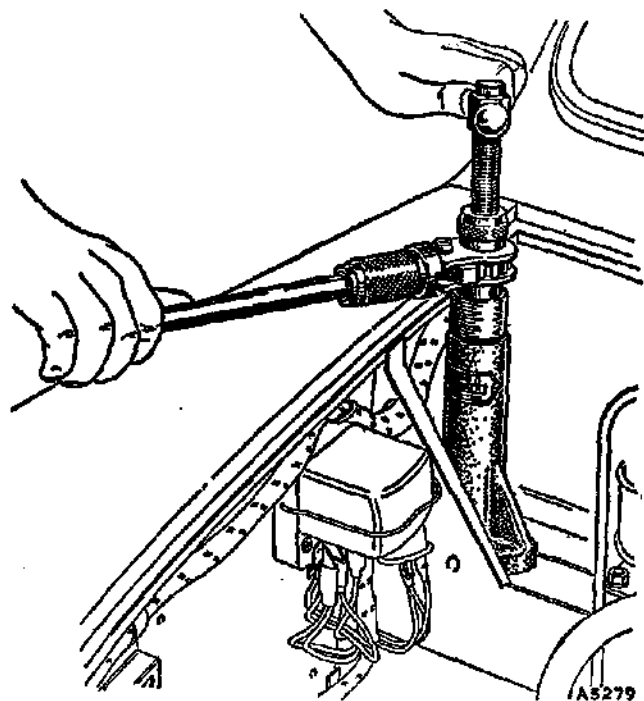

Fig. K.1

Compressing the spring unit using Service tool 18G 574 B

Section K.1

SPRING UNITS (Rubber Suspension)

Compressing

- (1) Slacken one bolt (or nut) and remove the other securing the sub-frame towers to the engine bulk-head cross-member.
- (2) Move the locking plate to one side to expose the access hole in the cross-member. Replace the bolt (or nut) and tighten both.
- (3) Insert Service tool 18G 574 B through the cross-member, locate the body of the tool over the two sub-frame bolts (or nuts), and screw the centre of the tool nine complete turns into the spring unit. Use the ratchet handle to turn the centre nut and make contact with the body of the tool. Hold the centre screw to prevent further rotation and then turn the ratchet handle clockwise to compress the spring sufficiently to allow removal of the spring strut from the tower. Do not over-compress the spring.

Removing

- (4) Jack up the car after compressing the spring, and remove the road wheel.
- (5) Remove the bump rubber from the tower.
- (6) Remove the retaining nut and release the upper suspension arm with Service tool 18G 1063.

K.2

- (7) With the spring unit compressed, lever the strut from the spring unit.
- (8) Detach the hydraulic damper, dismantle the upper arm pivot and remove the upper arm.
- (9) Hold the centre screw of the tool to prevent it turning, screw the ratchet handle upwards to release the spring compression, remove the tool, and extract the spring unit from the tower.

Refitting

- (10) Reverse the removing instructions.

Section K.2

SWIVEL HUBS

Removing

- (1) Jack up and remove the road wheel.
- (2) Remove the steering ball joint nut; to release the ball joint from the steering lever use Service tool 18G 1063.
- (3) Disconnect the drive shaft at the inner flexible joint undoing only the four outer 'U'-bolts and after marking the flange and joint for correct reassembly.
- (4) Disconnect the brake hose from the backplate.
- (5) Remove the upper suspension arm retaining nut and spring washer and release the arm from the pin using Service tool 18G 1063.
- (6) Disconnect the tie-rod from the lower arm; to release the hub from the arm use Service tool 18G 1063.
- (7) Withdraw the hub and drive shaft.

Dismantling

- (8) Remove the brake-drum.
- (9) Remove the split pin, nut, and distance washer and drive the shaft from the flange and hub.
- (10) Remove the drive shaft with Service tool 18G 304, using adaptor bolts 18G 304 F. Remove the driving flange from the hub with Service tool 18G 575.
- (11) Remove the inner and outer seal and the outer bearing spacer.
- (12) Drift out the inner race of each bearing, and use Service tools 18G 260 H to withdraw the outer races.

Reassembling

- (13) Reverse the dismantling instructions. Pack only the bearings with grease.

Refitting

- (14) Reverse the removing instructions.

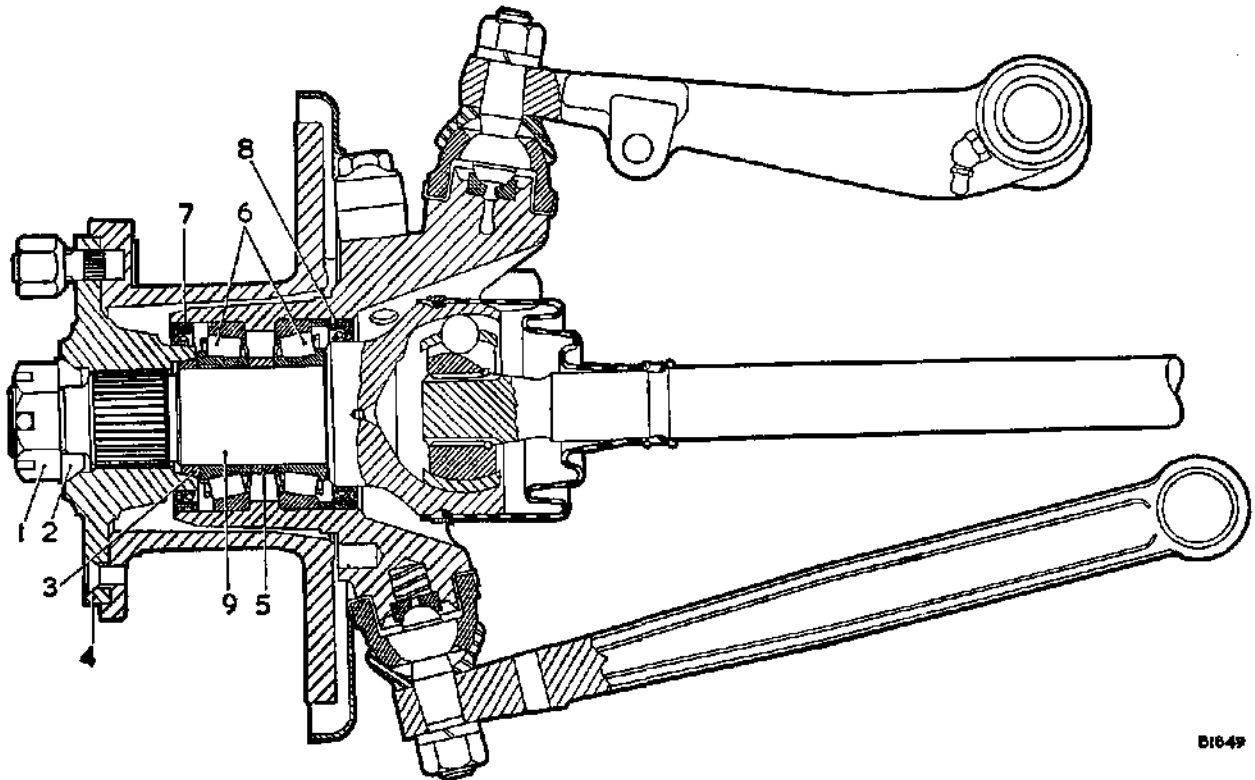

D1649

Fig. K.2
The front hub assembly (Cooper 'S')

- | | | |
|--|----------------------------|--------------------|
| 1. Drive shaft nut. | 4. Hub and disc assembly. | 7. Outer oil seal. |
| 2. Outer tapered collar. | 5. Bearing distance piece. | 8. Inner oil seal. |
| 3. Inner tapered collar (early models only). | 6. Taper-roller bearings. | 9. Drive shaft. |

COOPER AND COOPER 'S'

Carry out the instructions given in Section K.2 with the following modifications.

Removing

- (4) Remove the disc brake calliper (Section M.7).

Dismantling

COOPER

- (8) This instruction is not applicable.

COOPER 'S'

For items (8) to (12) substitute the following.

- (15) Remove the split pin and unscrew the drive shaft nut. Tap the end of the shaft with a hide mallet and pull off the driving flange and brake disc assembly, with the inner and outer split taper collars. Remove the drive shaft, the inner and outer bearing and distance piece from the hub.
- (16) Remove the inner and outer oil seals, drive out the inner and outer bearing cups using a brass drift. The shoulder of the hub has recesses to allow this. Take great care not to damage the bore of the hub.

Refitting

COOPER 'S'

- (17) Tighten the drive shaft nut to the correct tightness (see 'GENERAL DATA') and check for run-out on the periphery of the disc. If this exceeds .006 in. (.15 mm.), reposition the driving flange assembly on its splines until the run-out is within this limit.

Section K.3

SWIVEL HUB BALL JOINTS

Removing

- (1) Compress the spring unit as in Section K.1 or depressurize the Hydrolastic system as in Section H.7.
- (2) Jack up and support the car under the sub-frame side-member.
- (3) Remove the road wheel.
- (4) Disconnect the tie-rod from the lower arm.

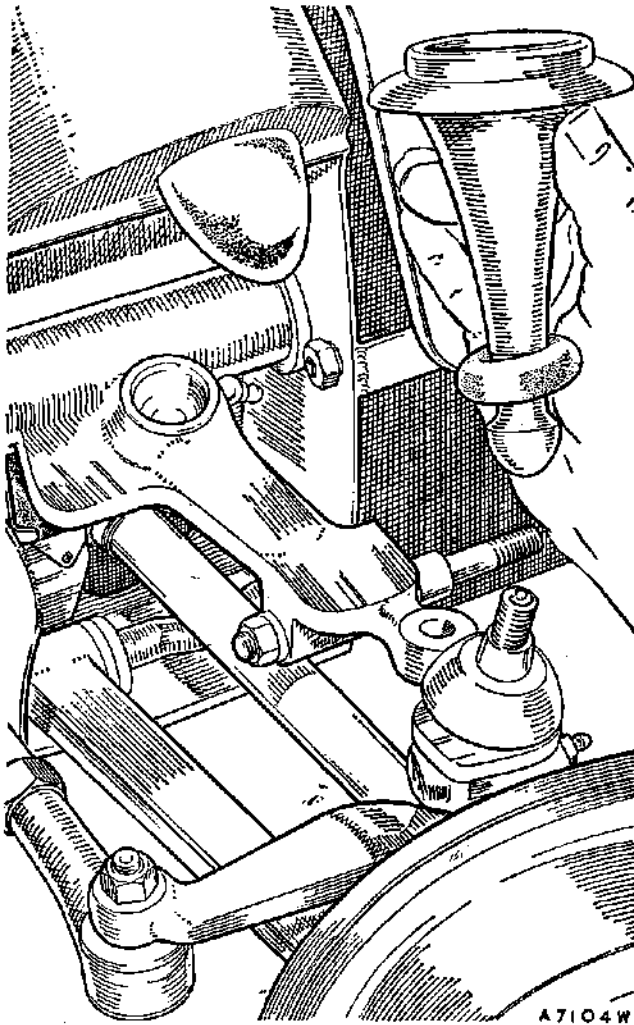

Fig. K.3

Removing the spring strut with the spring unit compressed and the upper support arm removed from the hub ball pin

- (5) Remove the upper suspension arm retaining nut and spring washer and release the arm from the pin using Service tool 18G 1063.
- (6) Remove the ball housing dust seal and the lubricator.
- (7) Knock up the lock washer and unscrew the housing to release the ball and seat.
- (8) Remove the lower ball joint in the same manner noting the spring fitted under the seat.
- (9) Clean all components.

Adjusting

- (10) Refit the ball pin seat, pin, and housing without the packing shims, locking washer (and spring in the lower assembly).
- (11) Screw down the housing until there is no free movement between the ball and seating and measure the gap between the housing and the swivel hub.
- (12) Remove the housing and ball pin, fit the shims to a thickness of the measurement minus the thickness

of the locking washer, .036 in. (.9 mm.). Add an additional shim so that the final assembly has no nip to .003 in. (.076 mm.) end-float. Pack the joint with grease, replace the locking washer and refit the assembly to the hub.

- (13) If with the housing tightened there is excessive end-float or tightness, the shims must be adjusted accordingly.

Refitting

- (14) Use Service tool 18G 372 with adaptor 18G 587 to tighten the ball pin retainer to the correct torque figure (see 'GENERAL DATA'). Tap up the locking washer on three flats, with one flat adjacent to the brake disc (on Cooper models) to secure the housing.
- (15) Replace the dust seal, refit the suspension arm and tighten the ball pin nut to the correct torque figure (see 'GENERAL DATA'). Reconnect the tie-rod to the lower arm.
- (16) Release the rubber spring unit from compression or pressurize the Hydrolastic system as in Section H.7.
- (17) Refit the road wheel and lower the car.

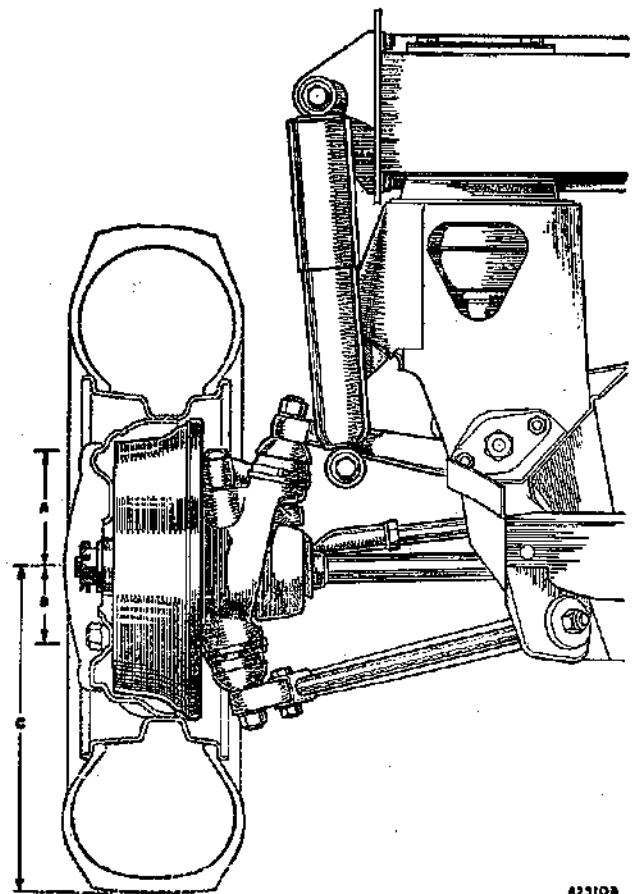

Fig. K.4

The general arrangement of the front suspension: (A) indicates the maximum upward deflection from normal, $3\frac{1}{8}$ in. (85 mm.); (B) the rebound figure, $2\frac{3}{8}$ in. (58 mm.); (C) the normal distance above ground surface

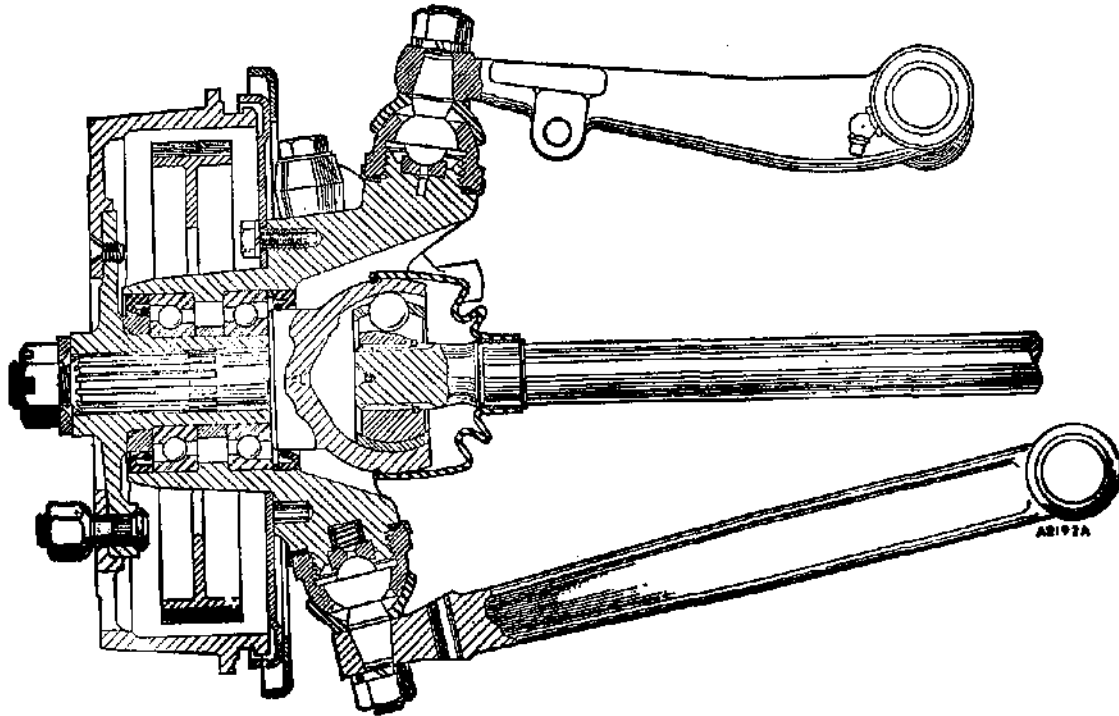

Fig. K.5
A section through the front suspension assembly

Section K.4

UPPER ARM
(Rubber Suspension)

Removing

- (1) Compress the spring as in Section K.1.
- (2) Jack up, remove the road wheel and damper, and remove the strut.
- (3) Remove the retaining nut and release the upper suspension arm with Service tool 18G 1063.
- (4) Remove the nut and washer from each end of the shaft.
- (5) Remove the front thrust collar retaining plate, the collar and the seal and push the shaft forward.
- (6) Remove the rear thrust washer and seal and manoeuvre the arm from the frame.
- (7) Extract the needle-roller bearings from the arm with Service tool 18G 581.

Refitting

Reverse the removing instructions, but note:

- (8) Lubricate all parts with grease.
- (9) Fit the needle-roller bearings with the marked ends outwards, using Service tool 18G 582 and adaptor 18G 582 A to push them into position.
- (10) Lubricate the spring unit strut nylon cup with Dextragrease Super G.P.

Section K.5

LOWER ARM

Removing

- (1) Jack up and remove the road wheel and damper.
- (2) Support the suspension with a jack under the brake-drum.
- (3) Disconnect the tie-rod from the lower arm.
- (4) Release the lower arm from the swivel hub with Service tool 18G 1063.
- (5) Remove the nut and washer from the rear end of the shaft and withdraw the shaft.

Refitting

Reverse the removing instructions, but note:

- (6) Support the lower arm in the normal position when the shaft nut is locked up to prevent pre-loading of the rubber bushes.

Section K.6

SUSPENSION STRUTS
(Rubber Suspension)

Some cars have been fitted with struts having a circular-section washer between the body of the suspension strut and the knuckle end. When fitting a new strut to these vehicles, make sure the washer is included.

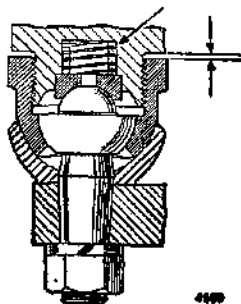

Fig. K.6

A section through the swivel hub ball joints. Take feeler gauge measurements at the positions indicated without the locking washers fitted and without the seat spring fitted to the lower ball joint

Section K.7

DISPLACER UNITS (Hydrolastic Suspension)

Removing

- (1) Jack up the car and remove the road wheel.
- (2) Depressurize and evacuate the Hydrolastic system (see Section H.7).
- (3) Release the displacer strut dust seal from the nylon seat and extract the strut from the displacer unit.
- (4) Disconnect the displacer hose from the union on the engine bulkhead.
- (5) Remove the suspension top arm (see Section K.4).
- (6) Push the displacer upwards and remove two screws to release the displacer bracket from inside the sub-frame tower.
- (7) Rotate the displacer anti-clockwise and withdraw it from the sub-frame.

Refitting

- (8) Reverse the removal instructions.
- (9) Rotate the displacer clockwise to lock it into the registers on the locating plate.
- (10) Lubricate the strut ball end and the nylon seat with Dextragrease Super G.P. and make sure the dust seal is fitted over the lip of the nylon cup.
- (11) Evacuate and pressurize the system (see Section H.7).

Section K.8

UPPER SUSPENSION ARMS (Hydrolastic Suspension)

Removal

Depressurize the Hydrolastic system as in Section H.7 and follow the instruction in K.4 for arm removal.

K.6

Section K.9

SWIVEL HUB OUTER OIL SEAL

The following instructions will permit a leaking outer seal to be replaced when the driving flange is removed.

NOTE.—A bearing overhaul will still require swivel hub removal as in Section K.3.

Removing

- (1) Remove the hub cover, extract the split pin, and slacken the drive shaft nut.
- (2) Slacken the wheel nuts and jack up the vehicle.
- (3) Take off the road wheel and remove the brake-drum.
- (4) Remove the drive shaft nut and assemble the Service tool 18G 304 and 18G 304 F to the drive flange.
- (5) Replace the Service tool centre screw with adaptor 18G 304 P and use the impulse extractor 18G 284 to remove the flange.
- (6) Should the outer bearing inner race come away with the driving flange, it can be removed with Service tool 18G 705 and adaptor 18G 705 B.

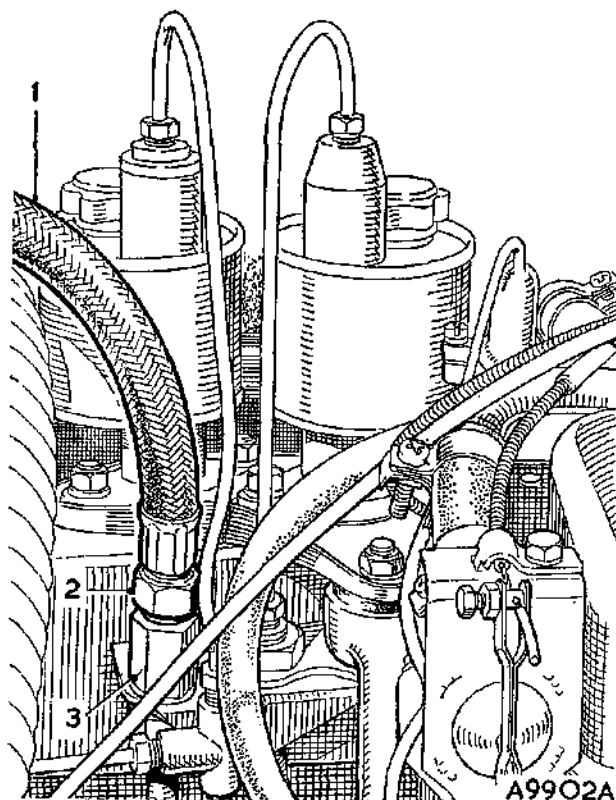

Fig. K.7

The right-hand front displacer hose connector

- | | |
|--------------------|--------------|
| 1. Displacer hose. | 2. Hose nut. |
| 3. Connector. | |

Refitting

- (7) Refit the inner bearing race (if extracted).
- (8) Fit the new seal and apply a suitable amount of lubricant to the lip to prevent burning.
- (9) Insert the outer bearing distance piece into the seal with the chamfered bore to the outside.
- (10) Assemble the drive flange to the hub, drifting it into position gently, turning the flange 180 degrees several times to align the bearing distance piece with the flange boss.
- (11) Refit the brake-drum.
- (12) Refit the drive shaft washer, chamfered bore facing inward and replace the nut.
- (13) Tighten the shaft nut to the torque figure given in 'GENERAL DATA' and secure with the split pin.



SECTION L

THE HYDRAULIC DAMPERS

| | <i>Section</i> |
|-------------------------------|----------------|
| Priming | L.2 |
| Removal and refitting | L.1 |
| Rear (Moke) | L.3 |

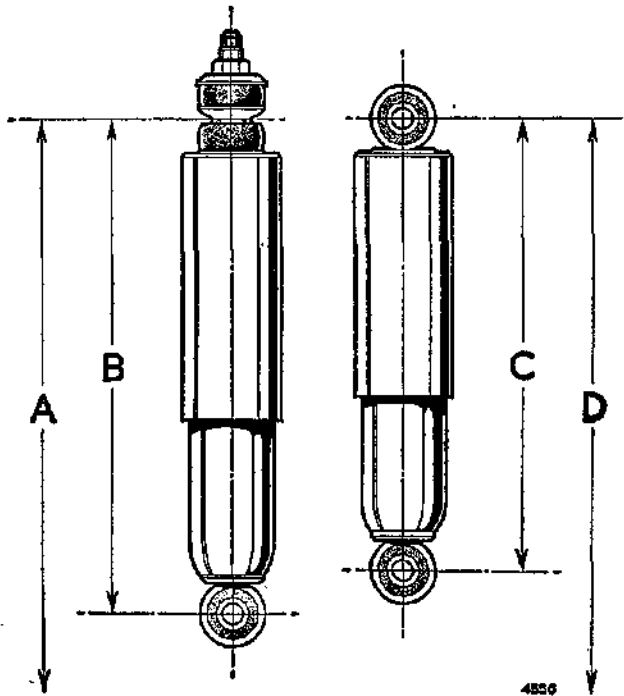

Fig. L.1

*The hydraulic dampers**Rear*

- A. Extended length 15 $\frac{3}{8}$ in. (385.76 mm.).
Van only 16 $\frac{1}{2}$ in. (409.6 mm.).
- B. Compressed length 9 $\frac{1}{8}$ in. (242.89 mm.).
Van only 10 in. (254 mm.).

Front

- C. Compressed length 8 $\frac{1}{2}$ in. (215.90 mm.).
- D. Extended length 12 $\frac{1}{4}$ in. (323.85 mm.).

Section L.1**REMOVAL AND REFITTING****Front**

- (1) Jack up and remove the road wheel.
- (2) Support the suspension under the brake-drum.
- (3) Remove the upper and lower securing nuts and pull the damper from the mounting spigots.
- (4) Hold the damper upright in a vice and compress and extend it six times to expel air. Retain the damper upright until refitted.
- (5) Fit new rubber bushes as required
- (6) Refit.

Right-hand damper (rear)

- (7) Remove the upper damper mounting nuts from inside the luggage boot.
- (8) Jack up the vehicle and remove the road wheel. Take off the lower mounting nut and washer collapse the damper, and remove it from its anchorage point on the radius arm.

- (9) Retain the damper in an upright position after removal from the car.
- (10) Make certain that the rubber bushes are in good condition; fit new bushes if they are worn or damaged.
- (11) Before refitting a damper to the vehicle it must be primed (see Section L.2).
- (12) When refitting the rear dampers make certain that the rubber cone spring and the spring strut are correctly located on their individual spigots whilst the radius arm is being raised to reconnect the upper end of the damper.

Left-hand damper (rear)

Access to the damper upper fixing nuts can only be obtained after the fuel tank has either been completely removed, or (as on most cars) it is only necessary to release the tank from its mounting position. On cars produced having a fuel tank with a rigid tube the tank must be drained and removed (see Section D.1).

To release the fuel tank

- (13) Remove the fuel filler cap and release the tank securing strap.
- (14) Pivot the tank around the tank front hose connection, taking care not to damage the hose, and lift the rear of the tank towards the centre-line of the car until access to the damper is obtained.
- (15) Remove and refit a damper as operation sequence (7) to (12) for right-hand damper.

Section L.2**PRIMING**

If air is suspected in a hydraulic damper, remove the damper from the vehicle and stand it in a vertical position for approximately five hours, then prime as follows.

Armstrong

Hold the damper vertically, extend to its full travel and then compress slowly. Continue to extend and compress until there is no free travel when changing direction of stroke.

Girling

Hold the damper, with the dust shield uppermost, at an angle of 15° to 20° to the vertical. Extend the damper about 76 mm. very slowly and then compress fully. Rotate the dust shield at the same time. Repeat until all free play has disappeared. Do not fully extend the damper during this process.

New dampers need only be held in their vertical position for a few minutes before priming. After priming, always store dampers in a vertical position.

Section L.3

REAR DAMPERS

(Moke)

Removing

- (1) Jack up and remove the road wheel.
- (2) Remove the cover from the upper mounting point inside the vehicle.
- (3) Remove the nuts from the upper and lower mounting points, collapse the damper, and pull it from its anchorage on the radius arm



SECTION M

THE BRAKING SYSTEM

| | <i>Section</i> |
|--|----------------|
| Adjustment | M.2 |
| Bleeding | M.8 |
| Disc brake calliper | M.7 |
| Intensifier | M.6 |
| Master cylinder | M.1 |
| Pressure regulating valve | M.5 |
| Shoe assemblies (and disc friction pads) | M.3 |
| Vacuum servo (Cooper 'S') | M.9 |
| Wheel cylinders | M.4 |
| Two-leading-shoe front brakes | M.10 |
| Preventive maintenance | M.11 |

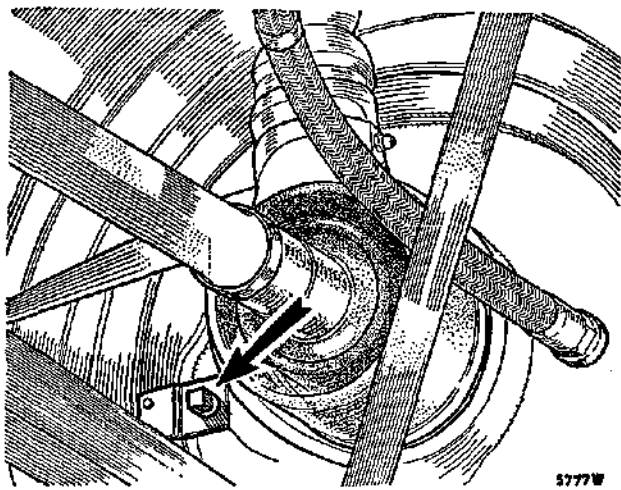

Fig. M.1

The front brake-shoe adjuster. One square-headed adjuster is provided on each of the four brake back-plates

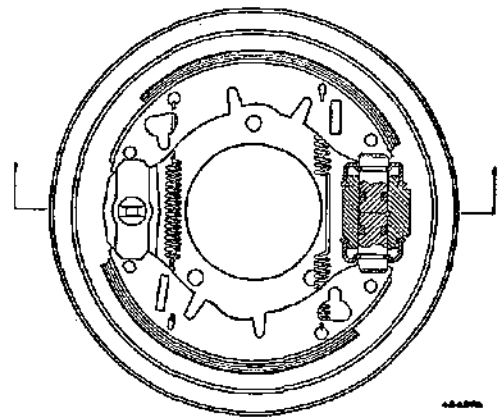
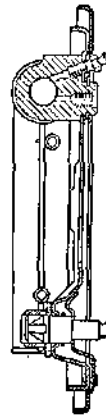

Fig. M.2

The right-hand front brake assembly, showing the fitted positions of the leading and trailing brake-shoes, with the pull-off springs anchored in the correct holes in the shoe web

Section M.1

MASTER CYLINDER

See Section E.4, but note the non-return valve fitted in this cylinder.

Section M.2

ADJUSTMENT

Early models have one square-headed adjuster screw projecting from each brake backplate. For adjustment on cars having two-leading-shoe brakes see Section M.10.

Jack up the car and turn the adjuster in a clockwise direction until the wheel is locked and then slacken the screw until the shoes are just free of the drum.

COOPER

Front disc brakes are not adjustable.

The rear brakes are adjusted as above.

Hand brake

ALL MODELS

- (1) Adjust the brake-shoes as detailed above.
- (2) Apply the hand brake to the third notch on the ratchet.
- (3) Take up excessive cable movement, turning the nuts at the lever trunnion until the wheels can only just be turned by heavy hand pressure.
- (4) Ensure that the wheels rotate freely when the hand brake is released.

Section M.3

SHOE ASSEMBLIES

Removing (front)

- (1) Jack up and remove the road wheel.
- (2) Unscrew the two retaining screws and pull off the drum.
- (3) Note the position of each spring; release them from the shoe webs and remove the springs and shoes.

NOTE.—Do not press the pedal when the shoes and springs have been removed.

Removing (rear)

As for the front shoes.

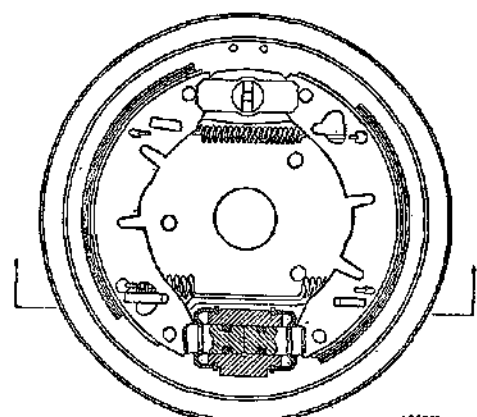
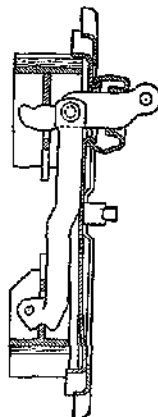

Fig. M.3

The right-hand rear brake assembly, showing the pull-off springs anchored in the correct holes in the shoe web

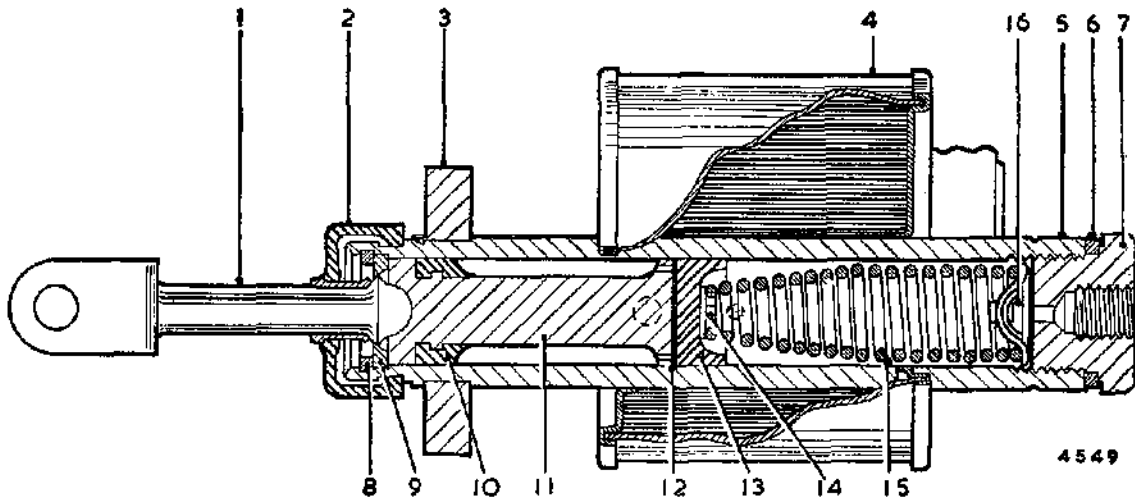

Fig. M.4

A section through the brake master cylinder

- | | | |
|---------------------|--------------------|-----------------------|
| 1. Push-rod. | 7. End plug. | 12. Piston washer. |
| 2. Rubber boot. | 8. Circlip. | 13. Main cup. |
| 3. Mounting flange. | 9. Stop washer. | 14. Spring retainer. |
| 4. Supply tank. | 10. Secondary cup. | 15. Return spring. |
| 5. Body. | 11. Piston. | 16. Non-return valve. |
| 6. Washer. | | |

4549

Refitting (front and rear)

Reverse the removing instructions.

COOPER

Removing disc brake friction pads

- (1) Jack up, remove the wheel.
- (2) Depress the pad retaining spring and withdraw the split pins (Fig. M.6).
- (3) Remove the spring and withdraw the pads from the calliper.
- (4) Thoroughly clean the exposed face of each piston and the recesses in the calliper.

On later cars the pads are retained in the callipers by means of split pins only. The pins pass through the calliper body and the pads, and no pad retaining springs are fitted. To remove the pads, it is only necessary to remove the split pins and extract the pads with a direct pull. Pads for the earlier- and later-type callipers are NOT INTERCHANGEABLE.

Refitting

- (5) Press the pistons back into the calliper with Service tool 18G 672.
- (6) Check that the cut-away edge of each piston is facing upwards and that anti-squeak shims are correctly placed.
- (7) Insert the new pads and check that they move easily in the calliper.
- (8) Remove any high spots from the pressure plate by careful filing.

- (9) Refit the spring, press it down and insert the split pins.

- (10) Press the pedal several times to adjust the brakes.

Section M.4

WHEEL CYLINDERS

Removing front and rear

- (1) Carry out instructions (1), (2), and (3) in Section M.3.
- (2) Thoroughly clean the backplate.
- (3) Disconnect the flexible hose.
- (4) Unscrew and remove the bleed screw.
- (5) Remove the circlip and dished washer from the cylinder boss protruding through the backplate and withdraw the cylinder.

COOPER

Removing (rear only)

As instructions (1) to (5) above.

Dismantling

- (6) Remove the dust seals from the ends of the cylinder and extract both pistons.
- (7) Remove the piston seals with the fingers only.
- (8) Clean all parts with brake fluid.

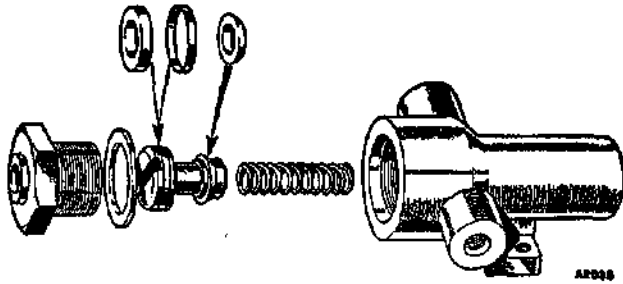

Fig. M.5

The hydraulic pressure regulating valve components

Reassembling

- (9) Fit new parts as required and then reverse the dismantling procedure.

Refitting

Reverse the removal instructions and bleed the system.

Section M.5

PRESSURE REGULATING VALVE

Removing

- (1) Disconnect the three pressure lines, unscrew the securing nut and withdraw the assembly from the rear sub-frame cross-member.

Overhauling

- (2) Clean the exterior.
- (3) Remove the end plug and sealing washer.
- (4) Extract the valve assembly and return spring.
- (5) If the rubber seals are not in good condition, fit a new piston and seal assembly.
- (6) Clean all parts with brake fluid, reassemble and refit.

Section M.6

INTENSIFIER

COOPER (Early models)

The brake intensifier is only fitted on early models. Later models have a pressure regulating valve incorporated in the system (see Section M.5).

Removing

- (1) Slacken the top pipe union, remove the nuts and washers and take out the mounting bolts.
- (2) Completely unscrew the top union and withdraw the pipe and union.

M.4

- (3) Unscrew the bottom pipe union and withdraw the pipe and union.
- (4) Remove the intensifier.

Dismantling

- (5) Hold the intensifier in a vice and unscrew the large hexagon plug.
- NOTE.**—The plug is under spring pressure.
- (6) Extract the piston assembly and springs.
 - (7) Thoroughly clean all parts with brake fluid and examine for wear.

Reassembling

- (8) Renew all worn or damaged parts. If the rubber seals have deteriorated, renew the piston assembly.

Refitting

Reverse the removing instructions.
Bleed the system.

Section M.7

DISC BRAKE CALLIPER

COOPER

Removing and dismantling

Do not separate the two halves of the calliper; each piston assembly must be dealt with individually.

- (1) Disconnect the tie-rod from the steering-arm.
- (2) Remove the locking plate from the dust cover.

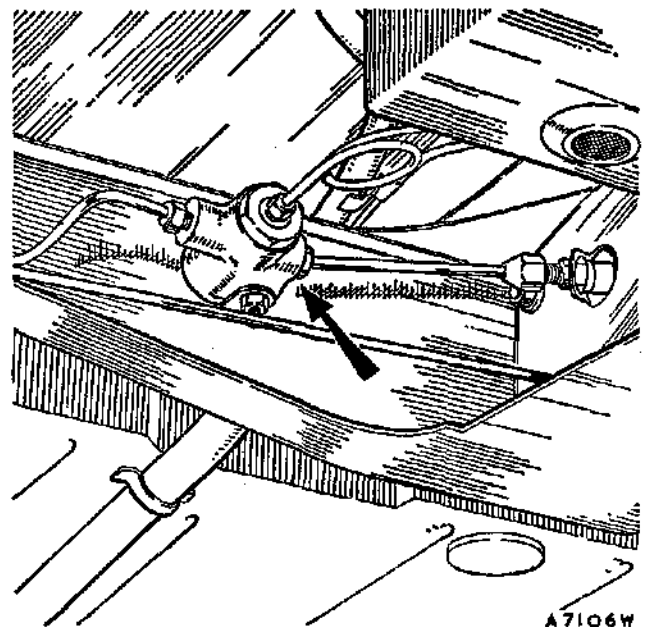

Fig. M.6

The hydraulic pressure regulating valve

- (3) Unscrew the two bolts securing the calliper to the hub, detach both parts of the dust cover and remove the calliper without disconnecting the brake pipe.
- (4) Withdraw the pads.
- (5) Clean the outside of the calliper.
- (6) Clamp the piston in the mounting half of the calliper.
- (7) Apply the brake pedal gently to force the other piston from the calliper.
- (8) Withdraw the fluid seal and the dust seal.

Reassembling

- (9) Coat a new fluid seal with Lockheed Disc Brake Lubricant and then ease it into its groove.
- (10) Slacken the bleeder screw one complete turn.
- (11) Coat the piston with Lockheed Disc Brake Lubricant, insert it into the bore with the cut-away face facing upwards and press it in with Service tool 18G 672 until about $\frac{5}{16}$ in. (8 mm.) remains protruding.
- (12) Coat a new, dry dust seal with Lockheed Disc Brake Lubricant, fit it to the retainer and position the seal and retainer on the protruding part of the piston with the seal innermost.
- (13) Press home the piston and seal.
- (14) Retighten the bleeder screw.
- (15) Clamp the piston in the rim half of the calliper and then repeat instructions (7) to (12).
- (16) Disconnect the hose and then repeat (13) and (14).
- (17) Reconnect the hose and refit the calliper and the two parts of the dust cover to the hub.

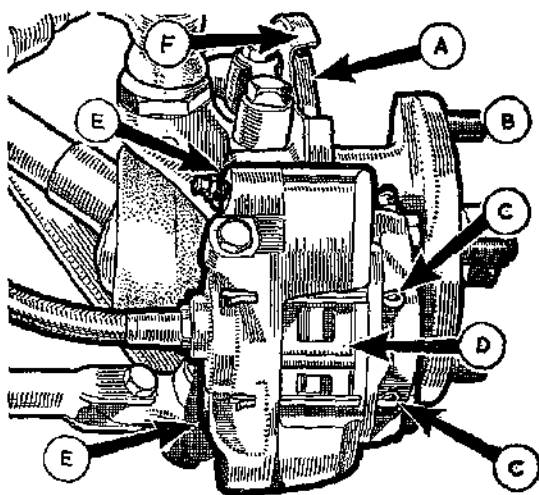

Fig. M.7

The disc brake assembly

- | | |
|----------------|-----------------------------|
| A. Brake disc. | D. Pad retaining spring. |
| C. Split pins. | E. Calliper mounting bolts. |
| F. Dust cover. | |

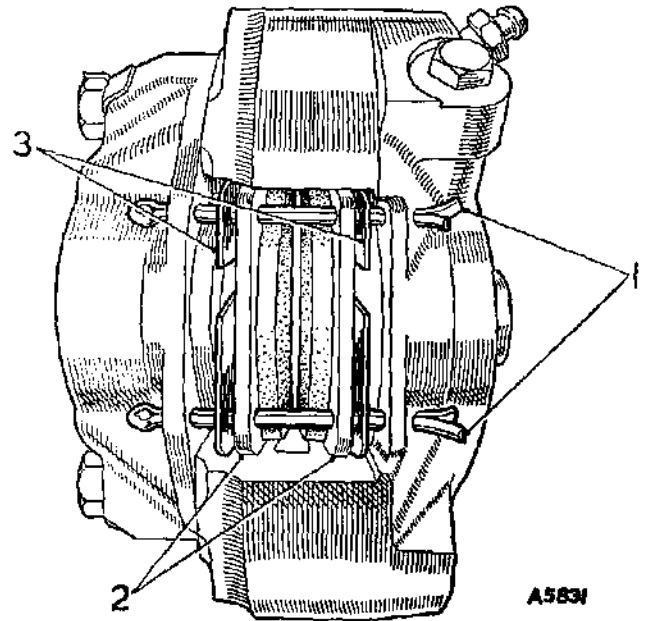

Fig. M.8

The modified calliper assembly

- | | |
|------------------------------|----------------|
| 1. Pad-retaining split pins. | 2. Brake pads. |
| 3. Anti-squeak shims. | |

- (18) Refit the dust cover locking plate.
- (19) Reconnect the tie-rod.
- (20) Tighten the calliper mounting bolts.
- (21) Fit the pads.
- (22) Bleed the brakes.
- (23) Apply the brakes several times to adjust.

Section M.8

BLEEDING

- (1) Adjust the brakes.
- (2) Slacken the bleeder screw on the intensifier (COOPER, when fitted) and pump the pedal until fluid comes out free from air.
- (3) Tighten the bleeder screw and top up the master cylinder.
- (4) Bleed the wheel cylinders. (Remove the front wheels—early COOPER).

Section M.9

VACUUM SERVO (Cooper 'S')

Removing

- (1) Disconnect the heater hose from the grille, release the clip retaining the hose to the slave cylinder and secure the hose out of the way.
- (2) Disconnect the hydraulic pipes from the slave cylinder, and plug the open ends of the pipes.

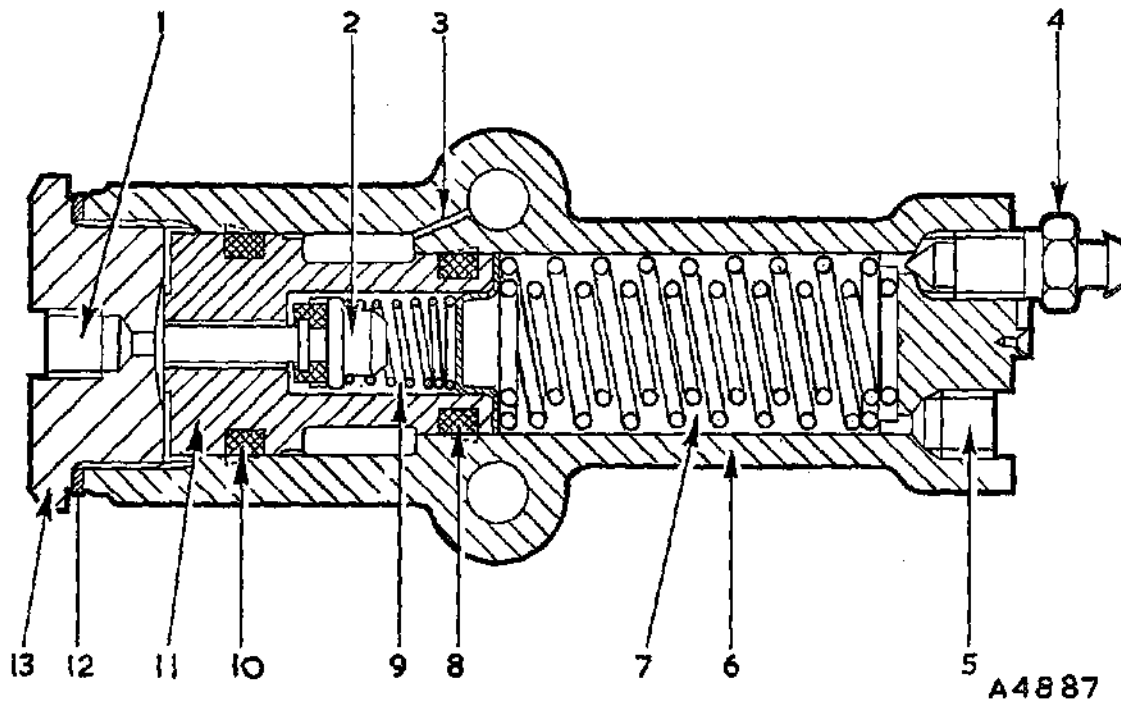

Fig. M.9

The brake cylinder intensifier

- | | | | |
|------------------------|-------------------------------|--------------------------|-----------------------|
| 1. Fluid inlet. | 5. Fluid outlet. | 8. Piston seal (small). | 11. Piston. |
| 2. Valve. | 6. Intensifier cylinder body. | 9. Valve return spring. | 12. Copper gasket. |
| 3. Air relief passage. | 7. Piston return springs. | 10. Piston seal (large). | 13. Hexagon end plug. |
| 4. Bleed screw. | | | |

- (3) Release the rubber vacuum pipe from the slave cylinder.
- (4) Remove the two retaining nuts and spring washers from the rear mounting bracket, release the servo unit from the front mounting bracket, and lift the unit from the vehicle.
- (5) Refitting is a reversal of removing. Bleed the brakes as described in Section M.8.

Dismantling

- (6) Remove the five screws and detach the air valve cover, disengaging the pipe from the rubber elbow. Pull the elbow off the pipe in the end cover, and lift out the control valve diaphragm.
- (7) Remove the four screws and lift off the valve housing and gasket. Expel the valve piston by closing the end connection with the thumb and applying a low air pressure at the smaller connection on the side of the cylinder. Ease the rubber cup off the piston.
- (8) Remove the bolts from the clamping ring, remove the end cover and diaphragm assembly, and disengage the return spring from the locking plates. Hold the push-rod by its hexagon centre-piece, ease off the rubber buffer and unscrew the nut to dismantle the diaphragm assembly.
- (9) Bend back the locking tabs, remove the four securing bolts, and detach the vacuum shell from

the slave cylinder. Extract the guide piece, push-rod cup, cup spreader and spring from the cylinder. Depress the piston with a suitable brass rod and extract the circlip. Gradually release the spring pressure on the piston, and remove the remaining components from the slave cylinder bore.

- (10) Unscrew the non-return valve from the side of the slave cylinder.

Cleaning

- (11) Wash all parts in industrial methylated spirit (not the air valve cover). Blow compressed air at a low pressure past the air valve and into the filter chamber. Dry all components thoroughly.

Reassembling

Reassembly is a reversal of the dismantling procedure, noting the following points.

- (12) Renew all metal parts showing signs of damage or wear.
- (13) New rubber seals, cups, and diaphragm should be used throughout.
- (14) Make an assembly sleeve to the following dimensions: length: 1.61 to 1.62 in. (40.89 to 41.15 mm.); outer diameter: .746 to .748 in. (18.95 to 19.00 mm.) inner diameter: .625 to .627 in. (15.87 to 15.92 mm.). Insert this sleeve in the end of the slave cylinder bore to refit the cap and piston.

- (15) Take extreme care not to damage the surface finish of the push-rod when reassembling the diaphragm. Lock the securing nut by punching the threads in two opposed places.
- (16) Do not tighten the end cover clamp bolt fully until the air valve cover has been fitted and the pipe in the end cover is lined up with the pipe and rubber elbow on the air valve cover.
- (17) Check that the diaphragm spring has its smaller end engaged under the locking plate tabs.

Section M.10

TWO-LEADING-SHOE FRONT BRAKES

Each front brake has two squared adjusters projecting from the rear face of the backplate, one adjuster for each brake-shoe.

Adjusting

- (1) Jack up the car and deal with one adjuster at a time.
- (2) Turn the adjuster in the same direction as the forward rotation of the front wheel until the drum is locked, then back off the adjuster the minimum amount necessary to allow the drum to rotate freely.
- (3) Spin the wheel and apply the foot brake firmly to centralize the shoe.
- (4) Re-check the adjustment, and repeat the complete operation with the other adjuster.
- (5) Carry out the same sequence on the other front wheel.

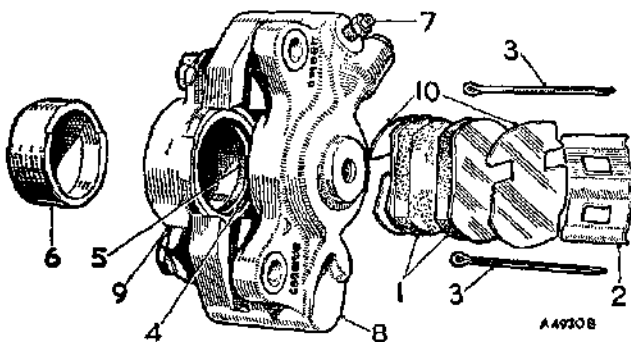

Fig. M.10

The calliper components

- 1. Friction pads.
- 2. Pad retaining spring.
- 3. Retaining split pins.
- 4. Piston dust seal.
- 5. Piston fluid seal.
- 6. Piston, showing cut-away at top.
- 7. Bleeder screw.
- 8. Mounting half calliper.
- 9. Rim half calliper.
- 10. Anti-squeak shim.

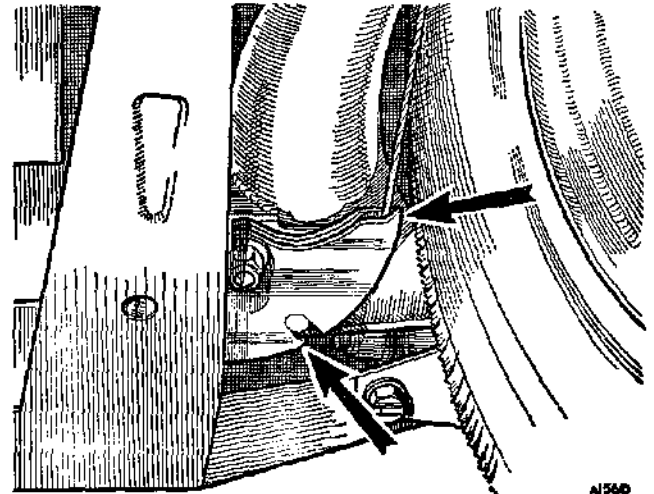

Fig. M.11

The hand brake cable sector mounted on the rear radius arms. Only the corners indicated must be 'nipped' to position the cable

Dismantling

- (6) Jack up the car and remove the front road wheel.
- (7) Back off both adjusters completely, extract the two retaining screws, and remove the brake-drum.
- (8) The tips of the brake-shoes are retained on the wheel cylinder pistons by spring-loaded hooks, one to each shoe. Withdraw the hooks from their registers in the pistons and turn them to one side.

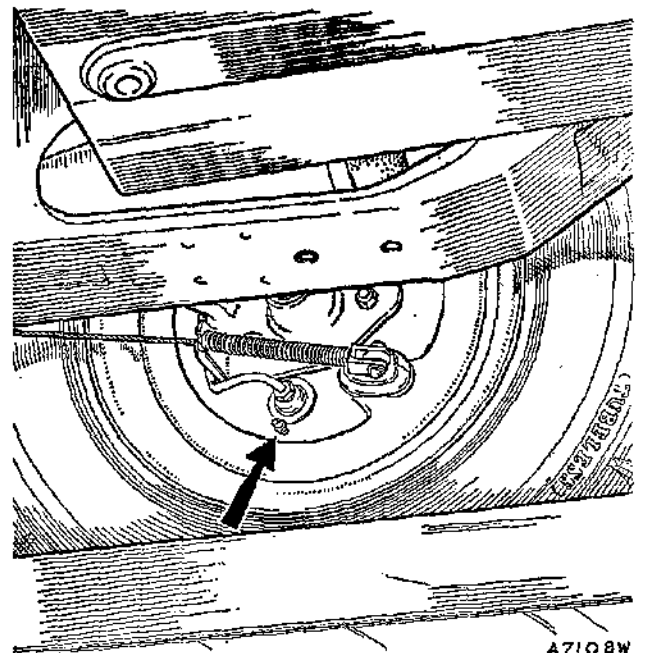

Fig. M.12

A rear wheel cylinder bleeder screw. One bleeder screw is provided on each of the four brake back-plates

- (9) Mark the position of the shoe return springs in the shoes, and note which end of the shoe is fitted to the wheel cylinder.
- (10) Lift out one shoe from the recesses in the wheel cylinder, and pivot against the pressure of the return spring. Manoeuvre the assembly of the shoes and springs over the front hub.
- (11) Wire the pistons to the wheel cylinder castings to prevent them from being accidentally pushed out.

Reassembly

- (12) Reassembly is a reversal of the dismantling procedure.
- (13) Ensure that the shoes are replaced the correct way round and the return springs are fitted in their correct positions.
- (14) The shoes must register correctly in the grooves in the pistons and pivot points.

Wheel cylinder removal

- (15) Remove the brake-shoes as described under 'Dismantling'.
- (16) Disconnect the flexible brake hose from the front wheel cylinder. Unscrew the two union nuts and detach the pipe bridging the two wheel cylinders.
- (17) Remove the two hexagon screws retaining each wheel cylinder to the backplate and detach the wheel cylinders.
- (18) Note, on replacement, that the piston of the wheel cylinder faces in the same direction as the forward rotation of the brake-drum and that the bleed screw is fitted to the rearmost wheel cylinder.

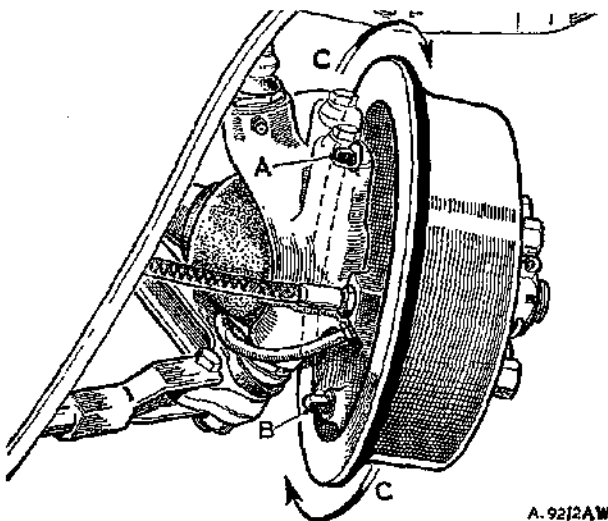

Fig. M.13

The adjusters for the two-leading-shoe front brakes
M.8

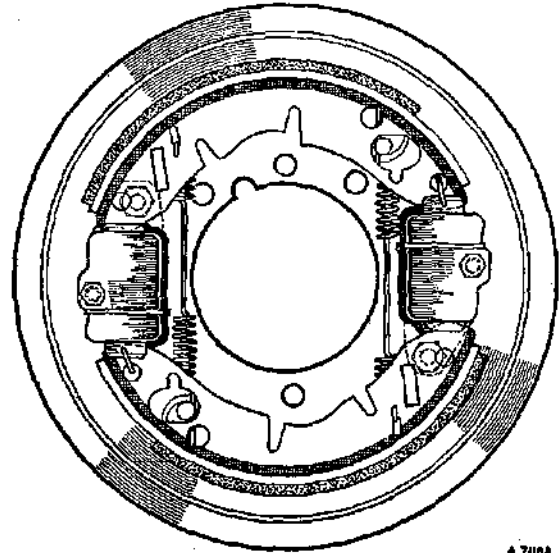

Fig. M.14

The left-hand front brake assembly, showing the fitted position of the shoes and pull-off springs

Section M.11

PREVENTIVE MAINTENANCE

To safeguard against the possible effects of wear, or deterioration, it is recommended that:

- (1) Disc brake pads, drum brake linings, hoses, and pipes should be examined at intervals no greater than those laid down in the Passport to Service.
- (2) Brake fluid should be changed completely every 18 months or 24,000 miles (40000 km.) whichever is the sooner.
- (3) All fluid seals in the hydraulic system and all flexible hoses should be examined and renewed if necessary every 3 years or 40,000 miles (65000 km.) whichever is the sooner. At the same time the working surface of the pistons and of the bores of the master cylinder, wheel cylinders, and other slave cylinders should be examined and new parts fitted where necessary.

Care must be taken always to observe the following points:

- (a) At all times use the recommended brake fluid.
- (b) Never leave fluid in unsealed containers. It absorbs moisture quickly and this can be dangerous.
- (c) Fluid drained from the system or used for bleeding is best discarded.
- (d) The necessity for absolute cleanliness throughout cannot be over-emphasized.

THE VACUUM SERVO COMPONENTS

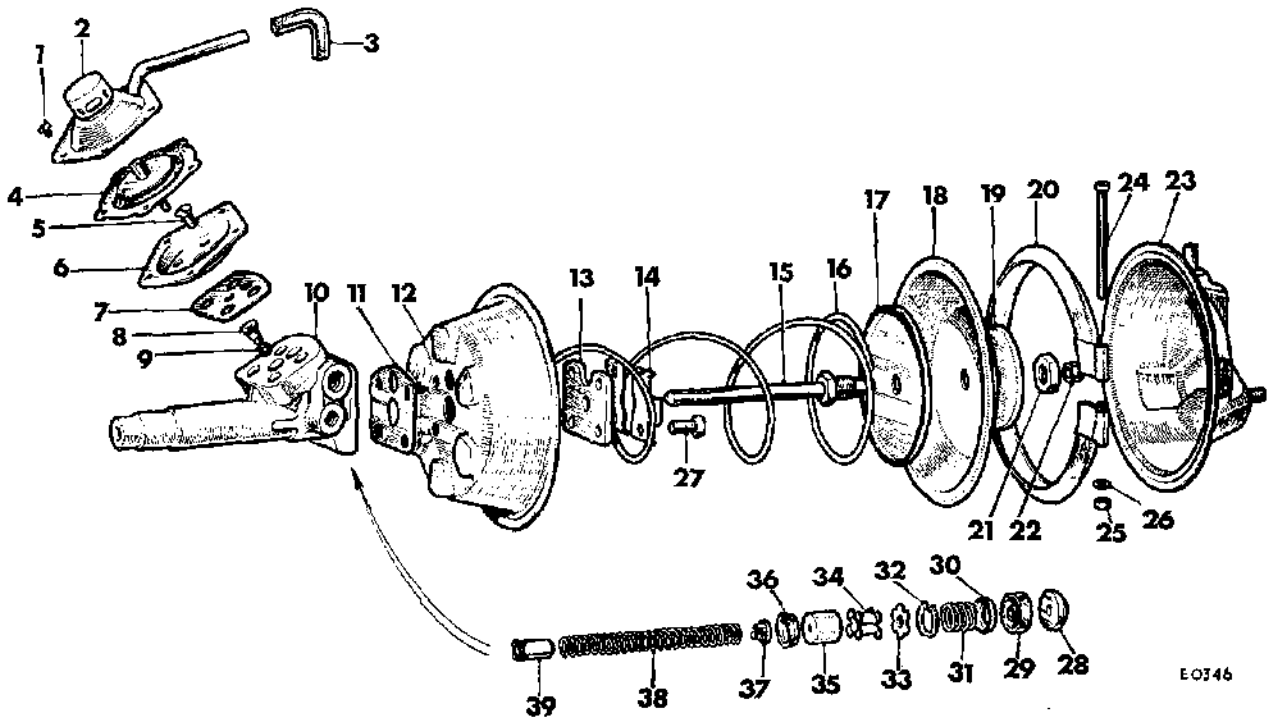

E0746

- | No. | Description |
|-----|--|
| 1. | Screw for air valve cover. |
| 2. | Air valve cover. |
| 3. | Rubber elbow. |
| 4. | Control valve diaphragm. |
| 5. | Screw for valve housing. |
| 6. | Valve housing. |
| 7. | Housing gasket. |
| 8. | Valve piston. |
| 9. | Rubber cup for piston. |
| 10. | Slave cylinder body. |
| 11. | Gasket—slave cylinder to vacuum shell. |
| 12. | Vacuum shell. |
| 13. | Abutment plate. |
| 14. | Locking plates. |
| 15. | Push-rod. |
| 16. | Return spring. |
| 17. | Plate (large) for diaphragm. |
| 18. | Diaphragm. |
| 19. | Plate (small) for diaphragm. |
| 20. | Clamping ring. |

- | No. | Description |
|-----|---------------------------------------|
| 21. | Nut for diaphragm assembly. |
| 22. | Rubber buffer. |
| 23. | End cover. |
| 24. | Clamping bolt. |
| 25. | Nut for clamping bolt. |
| 26. | Washer for nut. |
| 27. | Screw—vacuum shell to slave cylinder. |
| 28. | Guide piece. |
| 29. | Push-rod cup. |
| 30. | Cup spreader. |
| 31. | Spring. |
| 32. | Circlip. |
| 33. | Washer. |
| 34. | Distance piece. |
| 35. | Piston. |
| 36. | Cup. |
| 37. | Spring guide. |
| 38. | Spring. |
| 39. | Spring retainer. |



SECTION Mb

THE BRAKING SYSTEM

- The information contained in this Section refers specifically to new or modified components fitted to the Mini range coincident with the introduction of NEGATIVE earth electrical systems and must be used in conjunction with Section M. ●

| | <i>Section</i> |
|--|----------------|
| ●Bleeding the system (split braking system) | Mb.5 |
| Inertia valve (split braking system) | Mb.2 |
| Pressure failure switch (split braking system) | Mb.4 ● |
| Servo unit (Lockheed type 6) | Mb.1 |
| ●Tandem master cylinder (split braking system) | Mb.3 ● |

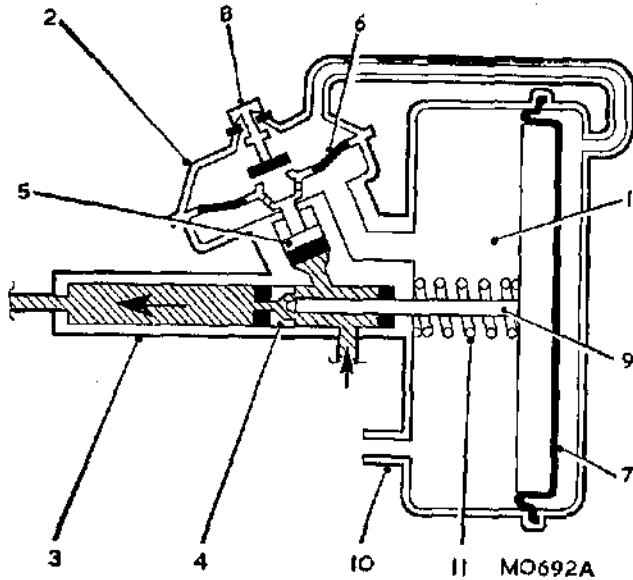

Fig. Mb.1

A schematic diagram showing the principle of operation and the main components of the vacuum servo unit. The shaded area represents brake fluid

Section Mb.1

SERVO UNIT (Lockheed Type 6)

Operation

Refer to Fig. Mb.1. The vacuum-operated servo unit consists of three main components, namely the vacuum cylinder (1), the air valve assembly (2), and the slave cylinder (3) which is connected in the hydraulic circuit between the main master cylinder and the wheel cylinders. Under light braking, fluid is allowed to pass directly to the wheel cylinders via the hollow centre of the slave piston (4) and no braking assistance is obtained; fluid pressure acting on the air valve piston (5) closes the diaphragm (6), thus separating the chamber behind the main servo diaphragm (7) from the one in front. Under heavier braking, further movement of the air valve piston opens the air valve and allows air to enter the chamber behind the main diaphragm, destroying the vacuum. The central rod (9) is thus pushed to the left, sealing the hollow centre of the slave piston and pushing it down its bore, so increasing the fluid pressure at the wheel cylinders. When the brake pedal is released, the pressure beneath the air valve piston is destroyed, the diaphragm (6) re-opens and the air valve closes. Via the non-return valve (10), a suspended vacuum is re-created around the main diaphragm. Under the action of the spring (11), the diaphragm and push-rod, and thus the slave piston, are returned to their original positions, and the pressure in the wheel cylinders is lost.

Mb.2

Removing

- (1) From beneath the right-hand front wing, pull the heater hose off the intake unit, and then withdraw the intake unit from inside the engine compartment.
- (2) Disconnect the vacuum pipe from the servo unit.
- (3) Remove the securing bracket from the end of the servo unit, disconnect the brake pipes and plug the holes.
- (4) Remove the nuts securing the servo to the bracket and withdraw the unit.

Dismantling

Air valve assembly (Fig. Mb.2)

- (5) Grip the slave cylinder in a soft-jawed vice with the air valve uppermost and disconnect the rubber pipe from the connection on the end cover.
- (6) Remove the screws securing the plastic air valve cover to the valve housing, lift off the cover complete with the air valve sub-assembly. Suspect functioning of the air valve must be remedied by fitting a replacement air valve cover assembly comprising cover, filter, and air valve as an assembled part of the relevant repair kit.
- (7) Remove the rubber diaphragm and its plastic support to obtain access to valve housing securing screws. Remove the three screws and take off the housing and joint washer.
- (8) Seal one of the slave cylinder fluid ports with a finger, apply a low-pressure air-line to the remaining port and blow the air control valve piston from its bore. Remove the rubber cup from the valve piston.

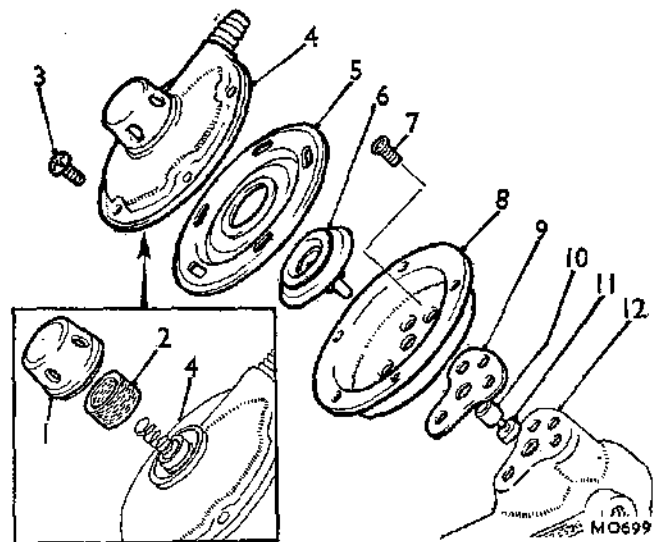

Fig. Mb.2

The air valve assembly components and piston

- | | |
|-------------------------------------|-----------------------------------|
| 1. Domed cover for filter. | 7. Valve housing securing screws. |
| 2. Air filter. | 8. Valve housing. |
| 3. Air valve cover securing screws. | 9. Joint washer. |
| 4. Air valve cover. | 10. Piston. |
| 5. Diaphragm. | 11. Piston cup. |
| 6. Diaphragm support. | 12. Slave cylinder. |

Servo cylinder assembly

- (9) Use thumb pressure to prise the non-return valve from the servo shell and extract the rubber valve mounting.
- (10) Remove the clamping ring securing the end cover to the servo shell and lift off the cover.
Early units. To remove the end cover from the servo shell fit Service tool C 2030* as shown in Fig. Mb.3. Turn the tool anti-clockwise with a ½ in. (13 mm.) square drive socket 'T' bar as far as the stops on the cover will allow and lift off the end cover. ●
- (11) Turn the diaphragm support so that the push-rod retaining key faces downwards. Apply light fluctuating hand pressure on the support into the shell; this will allow the retaining key to drop out, releasing the support from the push-rod under pressure of the main return spring. Extract the spring from the servo shell.
- (12) Bend back the locking tabs of the servo shell to slave cylinder securing bolts; remove the bolts, together with the locking and abutment plates. Lift off the servo shell and retrieve the joint washer from the mounting face of the slave cylinder.

Slave cylinder assembly

- (13) Pull the servo push-rod and the piston assembly attached to it from the slave cylinder bore. Slide off the plastic bearing, rubber cup and plastic spacer, noting their relative positions for refitting.
- (14) Prise off the rubber seal from the head of the slave piston. Open the retaining clip with a small screwdriver to expose the connecting pin, which may then be driven out to separate the piston from the rod (see Fig. Mb.4).

Inspecting

Examine all parts for faults and wear and be prepared to fit new rubber parts throughout. If the air valve is faulty, a replacement kit must be fitted. Dust deposits

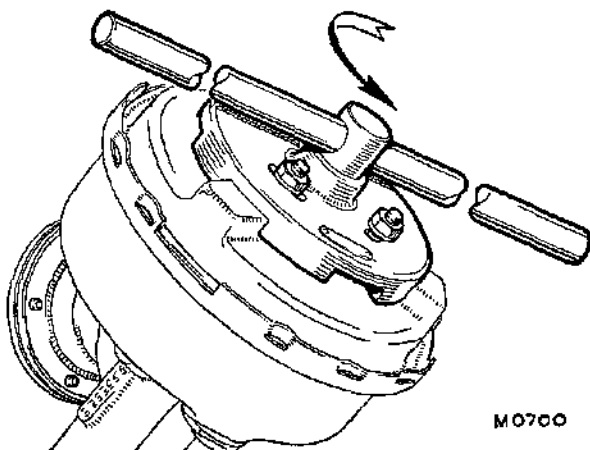

Fig. Mb.3

Using Service tool C2030* to remove and refit the end cover

* Obtainable from: V. L. Churchill & Co. Ltd.

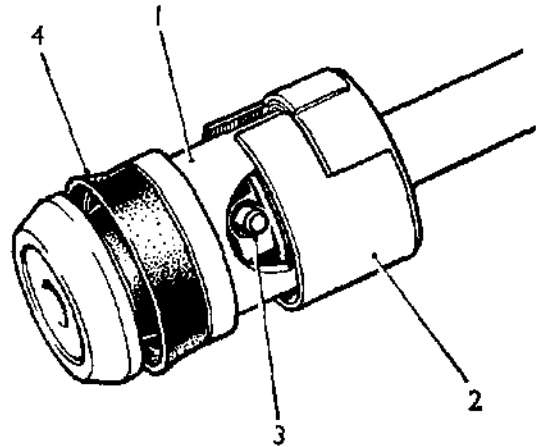

Fig. Mb.4

The slave piston, with the retaining clip withdrawn to expose the connecting pin

- 1. Piston body.
- 2. Retaining clip.
- 3. Connecting pin.
- 4. Piston seal.

on the air filter, which is otherwise in good condition, can be removed by blowing through with a low-pressure air-line. Do not use a cleaning fluid or lubricant of any description on the filter.

Wash all original components of the slave cylinder assembly and remove light deposits from the cylinder bore with clean brake fluid. If the slave cylinder bore is scored, a replacement unit will be required.

Reassembling

Scrupulous cleanliness of all parts of the servo unit is essential. Lay out all parts to be assembled on a clean sheet of paper. Use clean brake fluid as a lubricant when reassembling the hydraulic components of the servo unit.

Slave cylinder assembly

- (15) If the piston and push-rod were separated in item (14), a new retaining clip and connecting pin will be required. Insert the chamfered end of the push-rod into the rear of the piston and depress the spring inside it to uncover the hole in the end of the rod. Fit the pin, followed by its retaining clip; see that this is a snug fit, and does not protrude beyond its groove, otherwise the bore will become scored.

Using only the fingers, bed the rubber seal evenly into the groove on the head of the piston, with the lips of the seal pointing away from the push-rod.

- (16) Insert the piston into the lubricated bore of the slave cylinder, then, one by one, slide the spacer, the rubber cup, and the bearing over the push-rod into the mouth of the bore. Take care not to bend back the lips of either the seal or the cup, and bed in each part individually.

THE VACUUM SERVO COMPONENTS

(Lockheed Type 6)

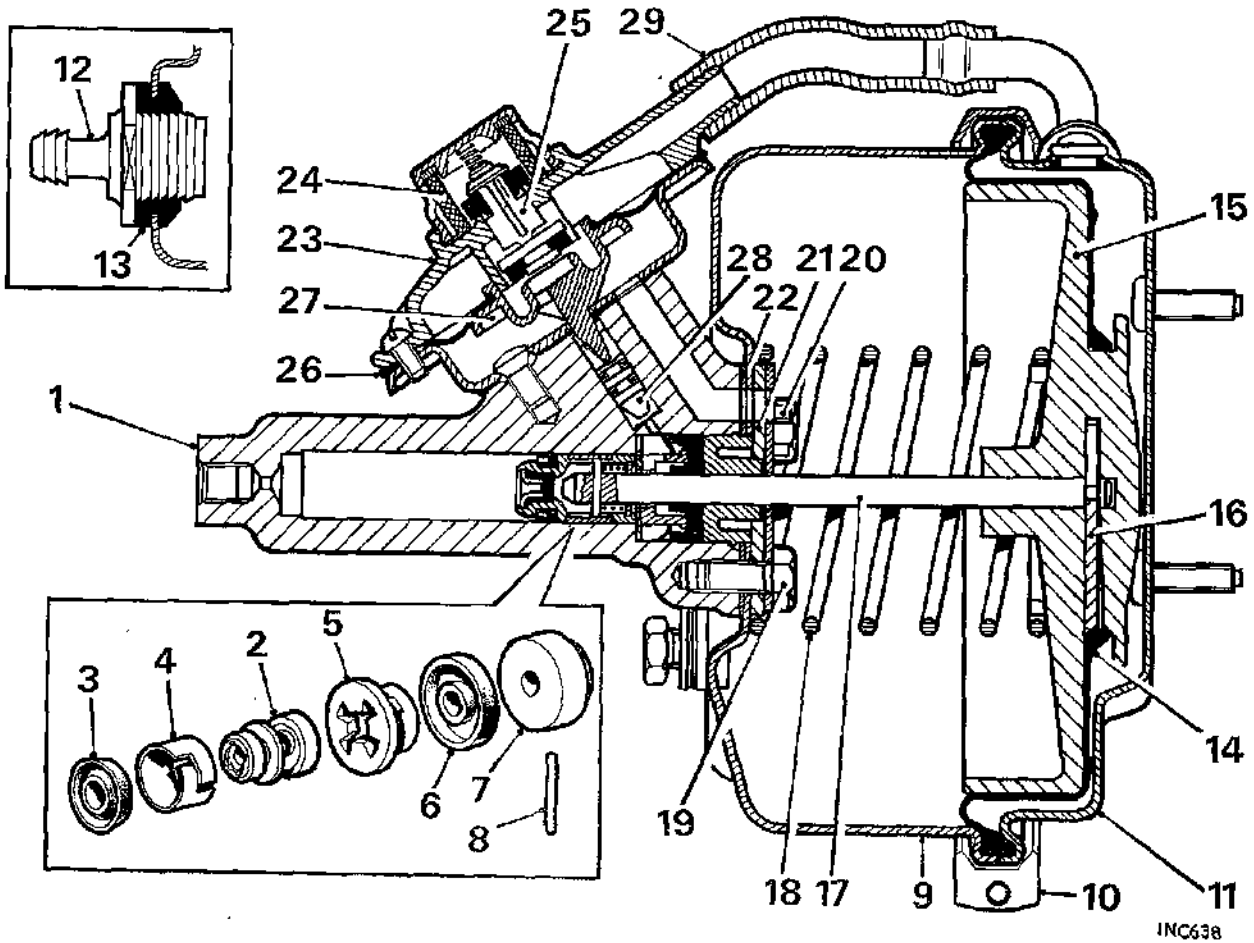

| No. | Description | No. | Description | No. | Description |
|-----|-----------------|-----|------------------------------|-----|----------------------|
| 1. | Slave cylinder. | 11. | End cover. | 21. | Abutment plate. |
| 2. | Slave piston. | 12. | Non-return valve. | 22. | Joint washer. |
| 3. | Piston seal. | 13. | Rubber mounting. | 23. | Air valve cover. |
| 4. | Retaining clip. | 14. | Main servo diaphragm. | 24. | Air filter. |
| 5. | Spacer. | 15. | Diaphragm support. | 25. | Air valve. |
| 6. | Cup. | 16. | Retaining key. | 26. | Air valve diaphragm. |
| 7. | Bearing. | 17. | Push-rod. | 27. | Diaphragm support. |
| 8. | Connecting pin. | 18. | Main return spring. | 28. | Air valve piston. |
| 9. | Servo shell. | 19. | Servo shell retaining bolts. | 29. | Rubber pipe. |
| 10. | Retaining clip. | 20. | Locking plate. | | |

Shown inset.

INC638

Servo cylinder assembly

- (17) Grip the slave cylinder in a soft-jawed vice, position the mounting face joint washer and refit the servo shell. After correctly positioning the abutment plate and locking plate, which must be renewed if it has been used more than once previously, tighten the three bolts evenly to the torque figure given in 'GENERAL DATA' and tap up the locking plate tabs.
- (18) Pull out the push-rod to its limit, fit the main return spring followed by the diaphragm support, with its key slot facing upwards. Make sure that the two end coils are located round the abutment plate and support boss respectively. Press the support into the shell until the groove in the end of the push-rod aligns with the key slot, and insert the key.

Ensure that both the rubber diaphragm and its support are perfectly dry and then fit the diaphragm to the support. Gently stretch the diaphragm to seat its inner edge in the groove of the support.

- (19) Smear the outer edge of the rubber diaphragm with Lockheed Disc Brake Lubricant where it will contact the rim of the end cover and of the shell, and position the diaphragm evenly around the rim of the shell.
- (20) Position the end cover with the shell so that the elbow is in alignment with the air valve and secure the two parts with the clamping ring.
Early units. Using Service tool C 2030* secured to the end cover, turn it clockwise as far as the stops will allow whilst maintaining downward pressure on the end cover. Take care not to trap the edge of the rubber diaphragm; remove the Service tool. ●

- (21) Push in the non-return valve with its rubber mounting.

Air valve assembly (Fig. Mb.2)

- (22) Using only the fingers, fit the rubber cup to the spigot of the air valve piston, with the lips pointing away from the drilled head, and insert the piston into its bore, spigot end first. Do not bend over the lips of the cup.
- (23) Fit the valve housing, with its joint washer, to the mounting face of the slave cylinder and tighten the three securing screws to the torque figure given in 'GENERAL DATA'.
- (24) Insert the spigot of the diaphragm support into the drilled head of the air valve piston, and then fit the inner edge of the air valve diaphragm into the groove of its support and align the screw hole slots. Do not use any lubricant.
- (25) Refit or replace the filter and snap-fit the dome cover if these have been removed in item (6). Place the valve cover over the diaphragm making sure that the projections on the under surface of the cover engage in the slots of the diaphragm. Tighten

the five securing screws firmly, progressively and diametrically; do not overtighten, since the smallest air leakage into the air valve assembly will impair the action of the servo.

- (26) Refit the rubber pipe to join the end cover elbow to the valve cover port.

Refitting

- (27) Reverse the removing procedure, items (1) to (4).
- (28) Bleed the braking system (Section Mb.5), using a recommended brake fluid, see 'GENERAL DATA'. ●

Fluid drained from the system or that used for bleeding should be discarded.

Section Mb.2

**INERTIA VALVE
(Split braking system)**

An inertia valve is fitted in the fluid line to the rear brakes; it replaces the pressure regulating valve described in Section M.5 and is similarly located on the rear sub-frame cross-member.

The angle at which the assembly is mounted allows the steel ball inside the body to hold the valve in the open position, so that fluid may pass to the rear brakes. When braking heavily, the weight transfer to the front of the vehicle causes the ball to move away from the valve, which is then closed by a light spring. Thus further pressure is prevented from reaching the rear brakes, and all additional pressure is transferred to the front brakes.

Removing

- (1) Remove, and then plug the ends of, the hydraulic brake pipes.

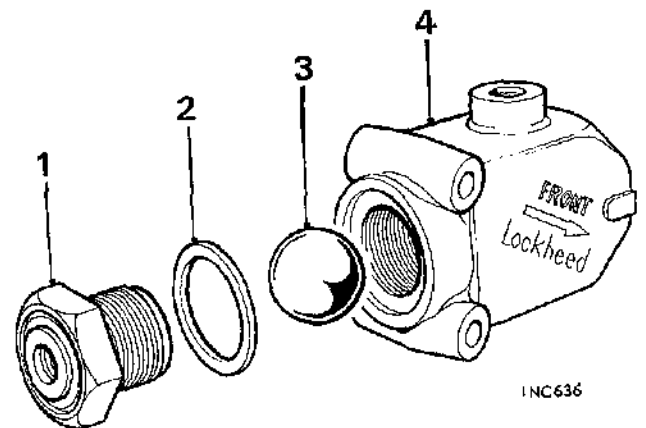

*Fig. Mb.5
The inertia valve assembly components*

- 1. Valve sub-assembly.
- 2. Copper washer.
- 3. Steel ball.
- 4. Valve body.

*Obtainable from V. L. Churchill & Co. Ltd.

- (2) Remove the two fixing bolts and lift the inertia valve assembly from its location on the rear sub-frame cross-member.

Dismantling and examining

- (3) Remove the end plug and washer from the inertia valve body, and extract the steel ball.
- (4) Clean the body and steel ball with clean brake fluid or industrial methylated spirit and dry thoroughly.
- (5) Carefully examine all the components, which must be in perfect condition if they are to be re-used.

Reassembling

- (6) Insert the steel ball into the body.
- (7) Screw in a new valve and end-plug sub-assembly, fitting a new copper washer. See that the seating faces of both the body assembly and end plug are clean and undamaged, and tighten to the torque figure given in 'GENERAL DATA'.

Refitting

- (8) Reverse the removing procedure noting the marking 'FRONT' on the inertia valve body.
- (9) Refill the master cylinder reservoir with the recommended brake fluid, see 'GENERAL DATA'.
- (10) Bleed the braking system as in Section Mb.5. Then inspect the inertia valve for fluid leaks with the foot brake pedal fully depressed and also with the system at rest.

NOTE.—Brake fluid can have a detrimental effect on paintwork; ensure that fluid is not allowed to contact paint-finished surfaces.

Section Mb.3.**TANDEM MASTER CYLINDER**

(Split braking system)

Removing

- (1) Disconnect the hydraulic pipes from the master cylinder, and plug the pipe ends to prevent loss of fluid and the entry of dirt.
- (2) Unscrew the two nuts securing the master cylinder to the bulkhead, and lift it off, leaving the push-rod attached to the brake pedal.

Dismantling

- (3) Drain the fluid from the reservoir and refit the cap.
- (4) Plug the pipe connections, thoroughly clean the exterior of the assembly and remove the rubber boot.
- (5) Grip the cylinder body in a soft-jawed vice with the mouth of the bore uppermost.

Refer to Fig. Mb.6.

- (6) Compress the return spring and remove the Spirolox ring from its groove in the primary piston, taking care not to distort the coils of the ring or score the bore of the cylinder.
- (7) Using Service tool 18G 1112, remove the piston retaining circlip. A slight radiusing of the sides of the tool may be necessary for ease of use on this master cylinder.
- (8) Move the piston up and down in the bore to free the nylon guide bearing and cap seal; remove the guide bearing and seal.
- (9) Remove the plain washer.
- (10) Using Service tool 18G 1112, remove the inner circlip.
- (11) Withdraw the primary and secondary piston assembly complete with stop washer.
- (12) Remove the stop washer.
- (13) Compress the spring separating the two pistons and drive out the roll-pin retaining the piston link.
- (14) Note the positions of the rubber cups by their moulded indentations and remove the cups and washers from the pistons.
- (15) Unscrew the four bolts securing the plastic reservoir to the body and remove the reservoir.
- (16) Remove the two reservoir sealing rings.
- (17) Unscrew the connection adaptors, discard the copper gaskets, and remove the spring and trap valves.

Inspecting

- (18) Clean all parts thoroughly in brake fluid and dry them with lint-free cloth.
- (19) Examine all metal components for wear and damage and renew all worn, damaged, or suspect parts.

Reassembling

- (20) Reverse the dismantling procedure, with special attention to the following points.
- (21) Use a complete set of new rubber seals when reassembling.
- (22) Immerse all the internal components in a recommended brake fluid as in item (26), and assemble them while wet.
- (23) Locate the piston washer (5) over the head of the secondary piston, convex surface first; carefully ease the secondary cup over the piston and seat it with its flat surface against the washer, see Fig. Mb.6.
- (24) The remainder is a reversal of the dismantling procedure (5) to (17). Fit new copper gaskets to the connection adaptors and tighten the connections to the torque figure given in 'GENERAL DATA'.

Refitting

- (25) Refit the unit, taking care to guide the push-rod into the opening in the rubber boot; re-connect and tighten pipe connections.

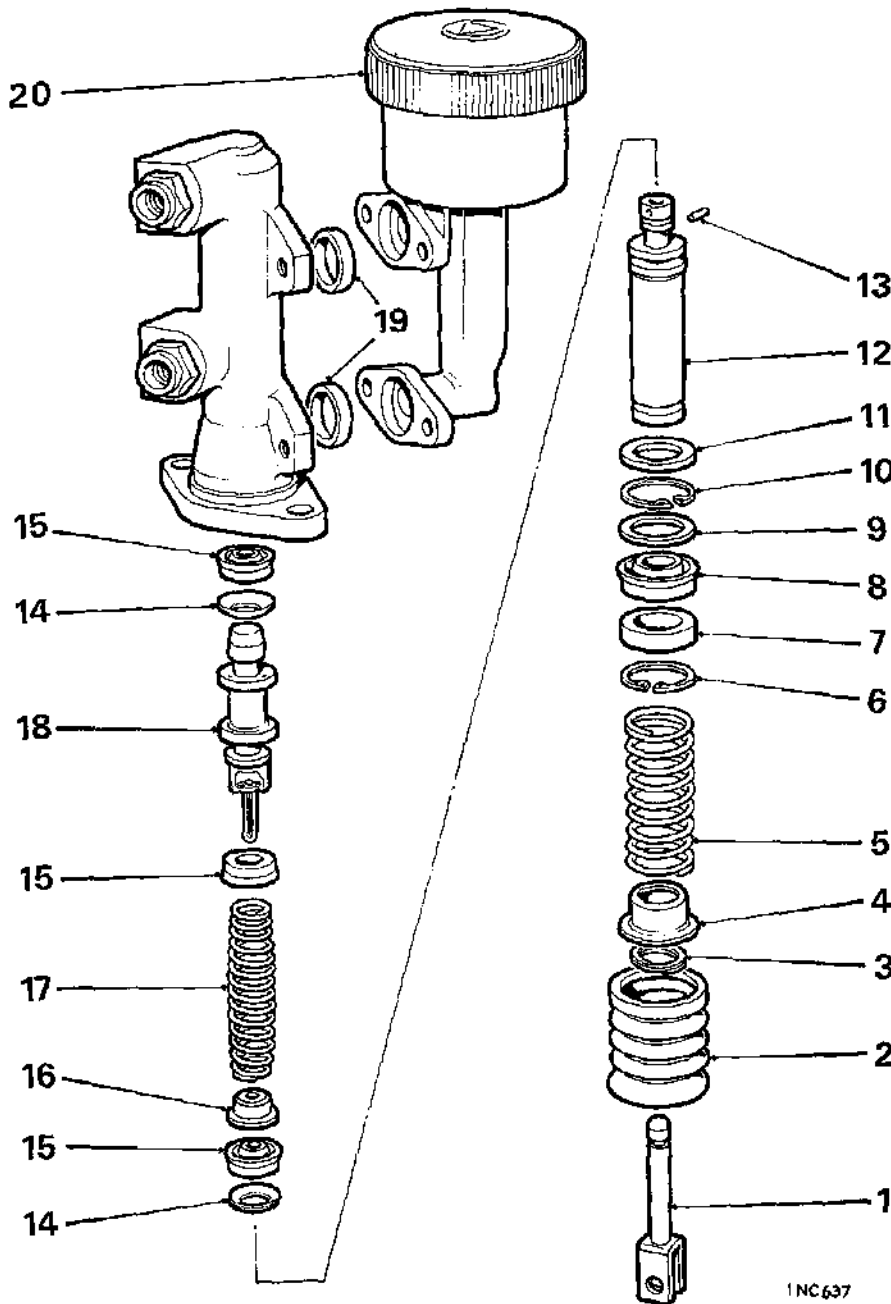

Fig. Mb.6
An exploded view of the tandem master cylinder components

1. Push-rod.
2. Rubber boot.
3. Spirolox ring.
4. Spring retainer.
5. Spring.
6. Circlip.
7. Nylon guide bearing.
8. Secondary cup.
9. Washer.
10. Circlip.
11. Stop washer.
12. Primary piston.
13. Roll pin.
14. Piston washer.
15. Main cup.
16. Pin retainer.
17. Spring.
18. Secondary piston.
19. Reservoir seals.
20. Fluid reservoir.

1NC637

- (26) Refill the cylinder reservoir with the recommended brake fluid, see 'GENERAL DATA'.
- (27) Bleed the braking system, see Section Mb.5.

NOTE.—Brake fluid can have a detrimental effect on paintwork; ensure that fluid is not allowed to contact paint-finished surfaces.

Section Mb.4.

PRESSURE FAILURE SWITCH ASSEMBLY
(Split braking system)

This switch replaces the three-way brake pipe connector located on the right-hand side of the engine bulkhead cross-member.

Removing

- (1) Pull the electrical connector off the nylon switch.
- (2) Clean the switch assembly and its surroundings, particularly the pipe connections.
- (3) Disconnect and plug the hydraulic pipes.
- (4) Unscrew the retaining bolt and remove the assembly.

Dismantling

- (5) Refer to Fig. Mb.7. Remove the end plug and discard the copper washer.
- (6) Unscrew the nylon switch.
- (7) Withdraw the shuttle valve piston assembly from the bore; use a low-pressure air line to free the piston if necessary.
- (8) Remove and discard the two piston seals.

Fig. Mb.7

The pressure failure switch components;
inset shows an exploded view of the
shuttle valve piston

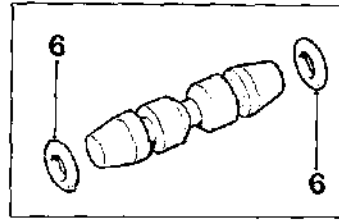

- | | |
|------------------|--------------------------|
| 1. Switch body. | 4. Copper washer. |
| 2. Nylon switch. | 5. Shuttle valve piston. |
| 3. End plug. | 6. Piston seals. |

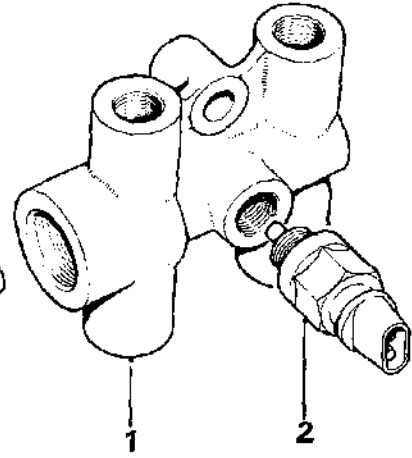
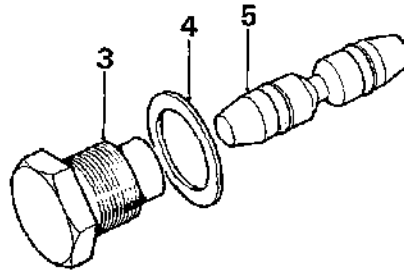

INA/04

Inspection

- (9) Thoroughly clean all the components using methylated spirit (denatured alcohol) or the recommended brake fluid, and dry with a lint-free cloth.
- (10) Inspect the bore of the casing for scoring and damage. The complete assembly must be renewed if the bore is not in perfect condition.
- (11) Reconnect the wiring to the switch and actuate the switch plunger to test the switch operation and warning light circuit.

Reassembling

- (12) Refer to Fig. Mb.7. Fit two new seals to the piston.
- (13) Lubricate the piston assembly with Lockheed Disc Brake Lubricant and fit the piston into the bore.
- (14) Fit a new copper washer to the end plug, screw in and tighten the plug to the torque figure given in 'GENERAL DATA'.
- (15) Screw in the switch and carefully tighten it to the torque figure given in 'GENERAL DATA'.

Refitting

- (16) Reverse the removing procedure in (1) to (4).
- (17) Refill the cylinder reservoir with the recommended brake fluid, see 'GENERAL DATA'.
- (18) Bleed the braking system, see Section Mb. 5.

Section Mb.5.

BLEEDING THE SYSTEM

(Split braking system)

- (1) Top up the hydraulic fluid reservoir to the correct level with the recommended brake fluid, see 'GENERAL DATA'. Do not allow the fluid level to drop more than $\frac{1}{2}$ in. (1.25 cm.) throughout the following operations.
- (2) Attach bleed tubes to the front and rear bleed screws on the driver's side of the car.
- (3) Submerge the open end of each tube in a small quantity of clean brake fluid in a transparent container.
- (4) Open both bleed screws half a turn.
- (5) Fully depress the brake pedal and hold it down.
- (6) Close both bleed screws and then allow the pedal to return.
- (7) Repeat operations (4), (5) and (6) until clean fluid, free from air, issues from both tubes. Having achieved this condition, repeat operations (4), (5) and (6) four more times.
- (8) Keep the brake pedal depressed and tighten both bleed screws to the correct torque.
- (9) Attach bleed tubes to the front and rear bleed screws on the opposite side of the car.
- (10) Carry out operations (3) to (8).

NOTE. Fluid from the system must be discarded. ●

SECTION Mb
THE BRAKING SYSTEM

The information given in this section refers to the Mini 1275 GT and Cooper 'S' Mk. III.

| | | |
|------------------------------|---------|------------------------|
| Servo unit (Lockheed type 6) | | <i>Section</i> Mb.1 |
|------------------------------|---------|------------------------|

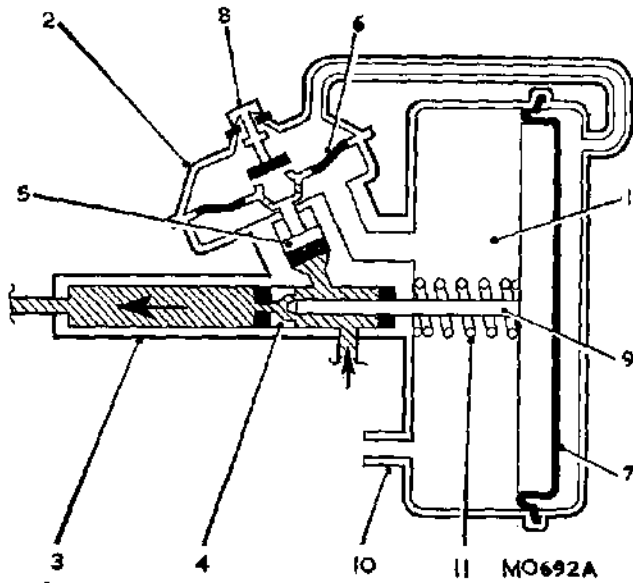

Fig. Mb.1

A schematic diagram showing the principle of operation and the main components of the vacuum servo unit. The shaded area represents brake fluid

Section Mb.1

SERVO UNIT (Lockheed Type 6)

Operation

Refer to Fig. Mb.1. The vacuum-operated servo unit consists of three main components, namely the vacuum cylinder (1), the air valve assembly (2), and the slave cylinder (3) which is connected in the hydraulic circuit between the main master cylinder and the wheel cylinders. Under light braking, fluid is allowed to pass directly to the wheel cylinders via the hollow centre of the slave piston (4) and no braking assistance is obtained; fluid pressure acting on the air valve piston (5) closes the diaphragm (6), thus separating the chamber behind the main servo diaphragm (7) from the one in front. Under heavier braking, further movement of the air valve piston opens the air valve and allows air to enter the chamber behind the main diaphragm, destroying the vacuum. The central rod (9) is thus pushed to the left, sealing the hollow centre of the slave piston and pushing it down its bore, so increasing the fluid pressure at the wheel cylinders. When the brake pedal is released, the pressure beneath the air valve piston is destroyed, the diaphragm (6) re-opens and the air valve closes. Via the non-return valve (10), a suspended vacuum is recreated around the main diaphragm. Under the action of the spring (11), the diaphragm and push-rod, and thus the slave piston, are returned to their original positions, and the pressure in the wheel cylinders is lost.

Mb.2

Removing

- (1) From beneath the right-hand front wing, pull the heater hose off the intake unit, and then withdraw the intake unit from inside the engine compartment.
- (2) Disconnect the vacuum pipe from the servo unit.
- (3) Remove the securing bracket from the end of the servo unit, disconnect the brake pipes and plug the holes.
- (4) Remove the nuts securing the servo to the bracket and withdraw the unit.

Dismantling

Air valve assembly (Fig. Mb.2)

- (5) Grip the slave cylinder in a soft-jawed vice with the air valve uppermost and disconnect the rubber pipe from the connection on the end cover.
- (6) Remove the screws securing the plastic air valve cover to the valve housing, lift off the cover complete with the air valve sub-assembly. Suspect functioning of the air valve must be remedied by fitting a replacement air valve cover assembly comprising cover, filter, and air valve as an assembled part of the relevant repair kit.
- (7) Remove the rubber diaphragm and its plastic support to obtain access to valve housing securing screws. Remove the three screws and take off the housing and joint washer.
- (8) Seal one of the slave cylinder fluid ports with a finger, apply a low-pressure air-line to the remaining port and blow the air control valve piston from its bore. Remove the rubber cup from the valve piston.

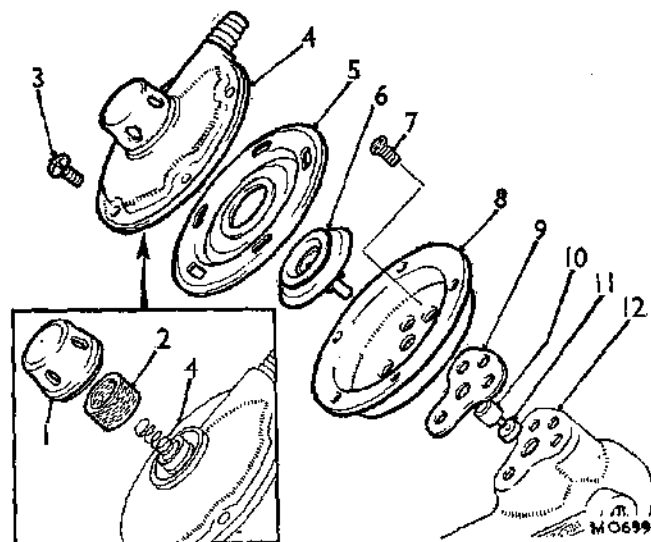

Fig. Mb.2

The air valve assembly components and piston

- | | |
|-------------------------------------|-----------------------------------|
| 1. Domed cover for filter. | 7. Valve housing securing screws. |
| 2. Air filter. | 8. Valve housing. |
| 3. Air valve cover securing screws. | 9. Joint washer. |
| 4. Air valve cover. | 10. Piston. |
| 5. Diaphragm. | 11. Piston cup. |
| 6. Diaphragm support. | 12. Slave cylinder. |

Servo cylinder assembly

- (9) Use thumb pressure to prise the non-return valve from the servo shell and extract the rubber valve mounting.
- (10) To remove the end cover from the servo shell, locate Service tool C 2030* over the three studs and secure tightly with suitable nuts (see Fig. Mb.3). Turn the removal tool anti-clockwise with a $\frac{1}{2}$ in. (13 mm.) square drive socket 'T' bar as far as the stops on the cover will allow and lift off the cover.
- (11) Turn the diaphragm support so that the push-rod retaining key faces downwards. Apply light fluctuating hand pressure on the support into the shell; this will allow the retaining key to drop out, releasing the support from the push-rod under pressure of the main return spring. Extract the spring from the servo shell.
- (12) Bend back the locking tabs of the servo shell to slave cylinder securing bolts; remove the bolts, together with the locking and abutment plates. Lift off the servo shell and retrieve the joint washer from the mounting face of the slave cylinder.

Slave cylinder assembly

- (13) Pull the servo push-rod and the piston assembly attached to it from the slave cylinder bore. Slide off the plastic bearing, rubber cup and plastic spacer, noting their relative positions for refitting.
- (14) Prise off the rubber seal from the head of the slave piston. Open the retaining clip with a small screwdriver to expose the connecting pin, which may then be driven out to separate the piston from the rod (see Fig. Mb.4).

Inspecting

Examine all parts for faults and wear and be prepared to fit new rubber parts throughout. If the air valve is faulty, a replacement kit must be fitted. Dust deposits

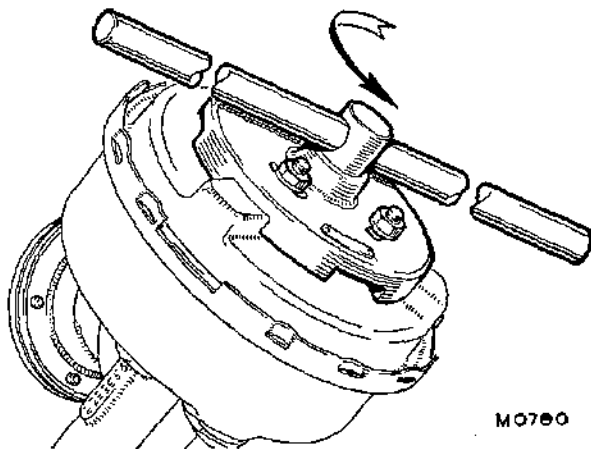

Fig. Mb.3

Using Service tool C2030 to remove and refit the end cover*

* Obtainable from: V. L. Churchill & Co. Ltd.

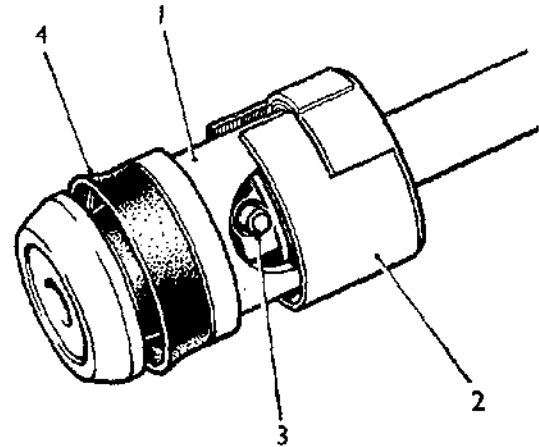

Fig. Mb.4

The slave piston, with the retaining clip withdrawn to expose the connecting pin

- | | |
|--------------------|--------------------|
| 1. Piston body. | 3. Connecting pin. |
| 2. Retaining clip. | 4. Piston seal. |

on the air filter, which is otherwise in good condition, can be removed by blowing through with a low-pressure air-line. Do not use a cleaning fluid or lubricant of any description on the filter.

Wash all original components of the slave cylinder assembly and remove light deposits from the cylinder bore with clean brake fluid. If the slave cylinder bore is scored, a replacement unit will be required.

Reassembling

Scrupulous cleanliness of all parts of the servo unit is essential. Lay out all parts to be assembled on a clean sheet of paper. Use clean brake fluid as a lubricant when reassembling the hydraulic components of the servo unit.

Slave cylinder assembly

- (15) If the piston and push-rod were separated in item (10), a new retaining clip and connecting pin will be required. Insert the chamfered end of the push-rod into the rear of the piston and depress the spring inside it to uncover the hole in the end of the rod. Fit the pin, followed by its retaining clip; see that this is a snug fit, and does not protrude beyond its groove, otherwise the bore will become scored.

Using only the fingers, bed the rubber seal evenly into the groove on the head of the piston, with the lips of the seal pointing away from the push-rod.

- (16) Insert the piston into the lubricated bore of the slave cylinder, then, one by one, slide the spacer, the rubber cup, and the bearing over the push-rod into the mouth of the bore. Take care not to bend back the lips of either the seal or the cup, and bed in each part individually.

THE VACUUM SERVO COMPONENTS

(Lockheed Type 6)

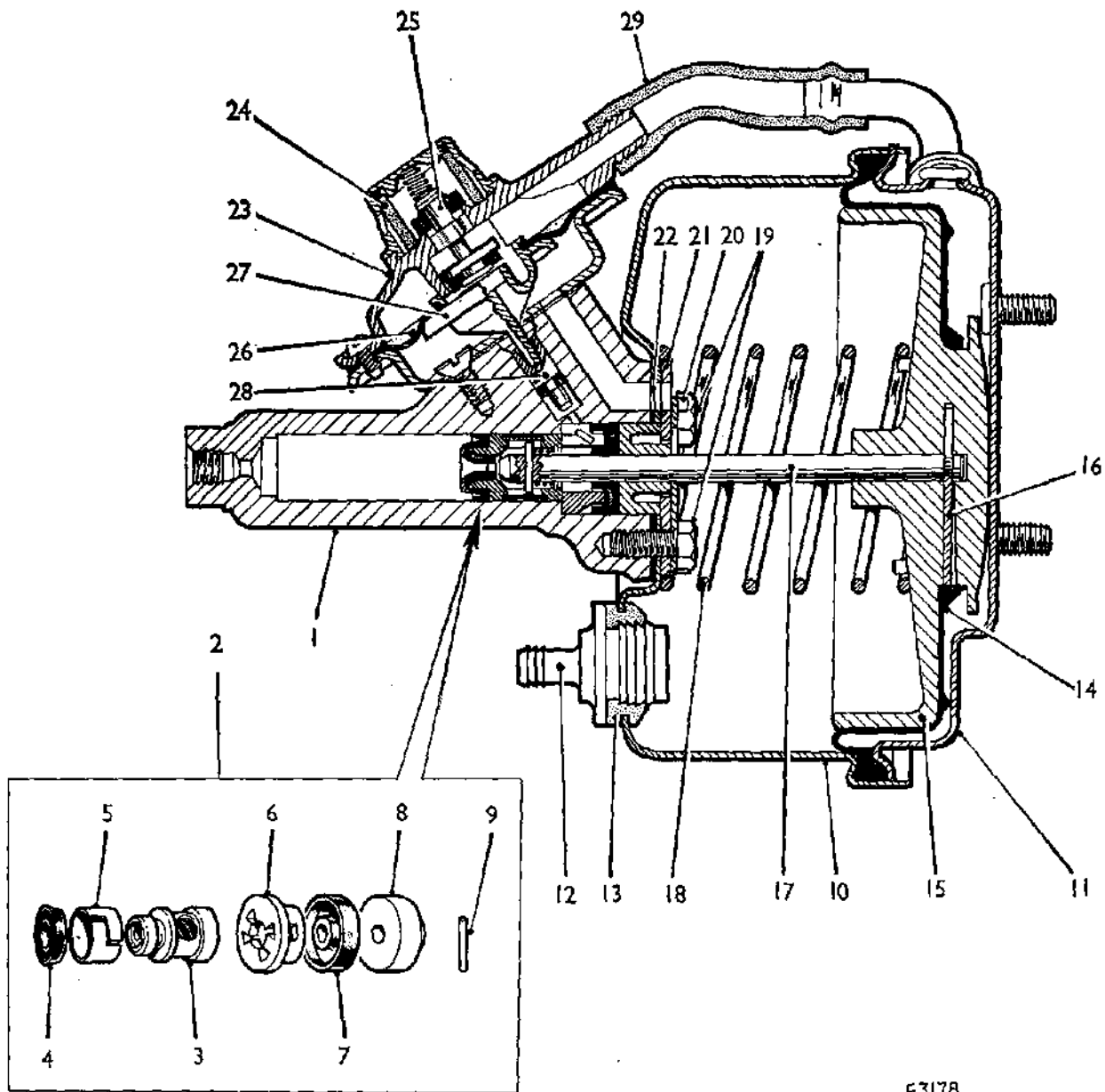

E3178

| No. | Description | No. | Description | No. | Description |
|-----|--------------------------|-----|------------------------------|-----|----------------------|
| 1. | Slave cylinder. | 11. | End cover. | 21. | Abutment plate. |
| 2. | Slave piston components. | 12. | Non-return valve. | 22. | Joint washer. |
| 3. | Slave piston. | 13. | Rubber mounting. | 23. | Air valve cover. |
| 4. | Piston seal. | 14. | Main servo diaphragm. | 24. | Air filter. |
| 5. | Retaining clip. | 15. | Diaphragm support. | 25. | Air valve. |
| 6. | Spacer. | 16. | Retaining key. | 26. | Air valve diaphragm. |
| 7. | Cup. | 17. | Push-rod. | 27. | Diaphragm support. |
| 8. | Bearing. | 18. | Main return spring. | 28. | Air valve piston. |
| 9. | Connecting pin. | 19. | Servo shell retaining bolts. | 29. | Rubber pipe. |
| 10. | Servo shell. | 20. | Locking plate. | | |

Servo cylinder assembly

- (17) Grip the slave cylinder in a soft-jawed vice, position the mounting face joint washer and refit the servo shell. After correctly positioning the abutment plate and locking plate, which must be renewed if it has been used more than once previously, tighten the three bolts evenly to the torque figure given in 'GENERAL DATA' and tap up the locking plate tabs.
- (18) Pull out the push-rod to its limit, fit the main return spring followed by the diaphragm support, with its key slot facing upwards. Make sure that the two end coils are located round the abutment plate and support boss respectively. Press the support into the shell until the groove in the end of the push-rod aligns with the key slot, and insert the key.

Ensure that both the rubber diaphragm and its support are perfectly dry and then fit the diaphragm to the support. Gently stretch the diaphragm to seat its inner edge in the groove of the support.

- (19) Smear the outer edge of the rubber diaphragm with Lockheed Disc Brake Lubricant where it will contact the rim of the end cover and of the shell, and position the diaphragm evenly around the rim of the shell.
- (20) Refit and secure Service tool C2030* to the end cover (see Fig. Mb.3). Position the end cover with the shell so that the elbow will be in alignment with the air valve. Whilst maintaining a downward pressure on the cover, turn it clockwise as far as the stops will allow, taking care not to trap the edge of the rubber diaphragm. Remove the Service tool.
- (21) Push in the non-return valve with its rubber mounting.

Air valve assembly (Fig. Mb.2)

- (22) Using only the fingers, fit the rubber cup to the spigot of the air valve piston, with the lips pointing away from the drilled head, and insert the piston into its bore, spigot end first. Do not bend over the lips of the cup.
- (23) Fit the valve housing, with its joint washer, to the mounting face of the slave cylinder and tighten the three securing screws to the torque figure given in 'GENERAL DATA'.
- (24) Insert the spigot of the diaphragm support into the drilled head of the air valve piston, and then fit the inner edge of the air valve diaphragm into the groove of its support and align the screw hole slots. Do not use any lubricant.
- (25) Refit or replace the filter and snap-fit the dome cover if these have been removed in item (6). Place the valve cover over the diaphragm making sure that the projections on the under surface of the cover engage in the slots of the diaphragm. Tighten the five securing screws firmly, progressively and diametrically; do not overtighten, since the smallest air leakage into the air valve assembly will impair the action of the servo.
- (26) Refit the rubber pipe to join the end cover elbow to the valve cover port.

Refitting

- (27) Reverse the removing procedure, items (1) to (4).
- (28) Bleed the braking system using clean Lockheed Brake Fluid (Series 329).
Fluid drained from the system or that used for bleeding should be discarded.



SECTION N

THE ELECTRICAL SYSTEM

| | <i>Section</i> |
|--|----------------------|
| Alternator (11AC) | |
| Control unit (4TR) | N.13 |
| Dismantling and overhauling | N.12 |
| Relay | N.14 |
| Service precautions | N.10 |
| Testing the charging circuit in position | N.11 |
| Warning light control | N.15 |
| Battery | N.1 |
| Bi-metal resistance instrumentation | N.7 |
| Cut-out | N.5 |
| Dynamo | N.2 |
| Lamps | N.6 |
| Starter | N.3 |
| Voltage regulator | N.4 |
| Windscreen wiper motor (Moke) | N.8 |
| Windscreen wiper wheelboxes | N.9 |
| Wiring diagrams | Beginning of Section |

WIRING DIAGRAM

Super, Super De-luxe, Countryman, Traveller and Cooper (up to 1964)

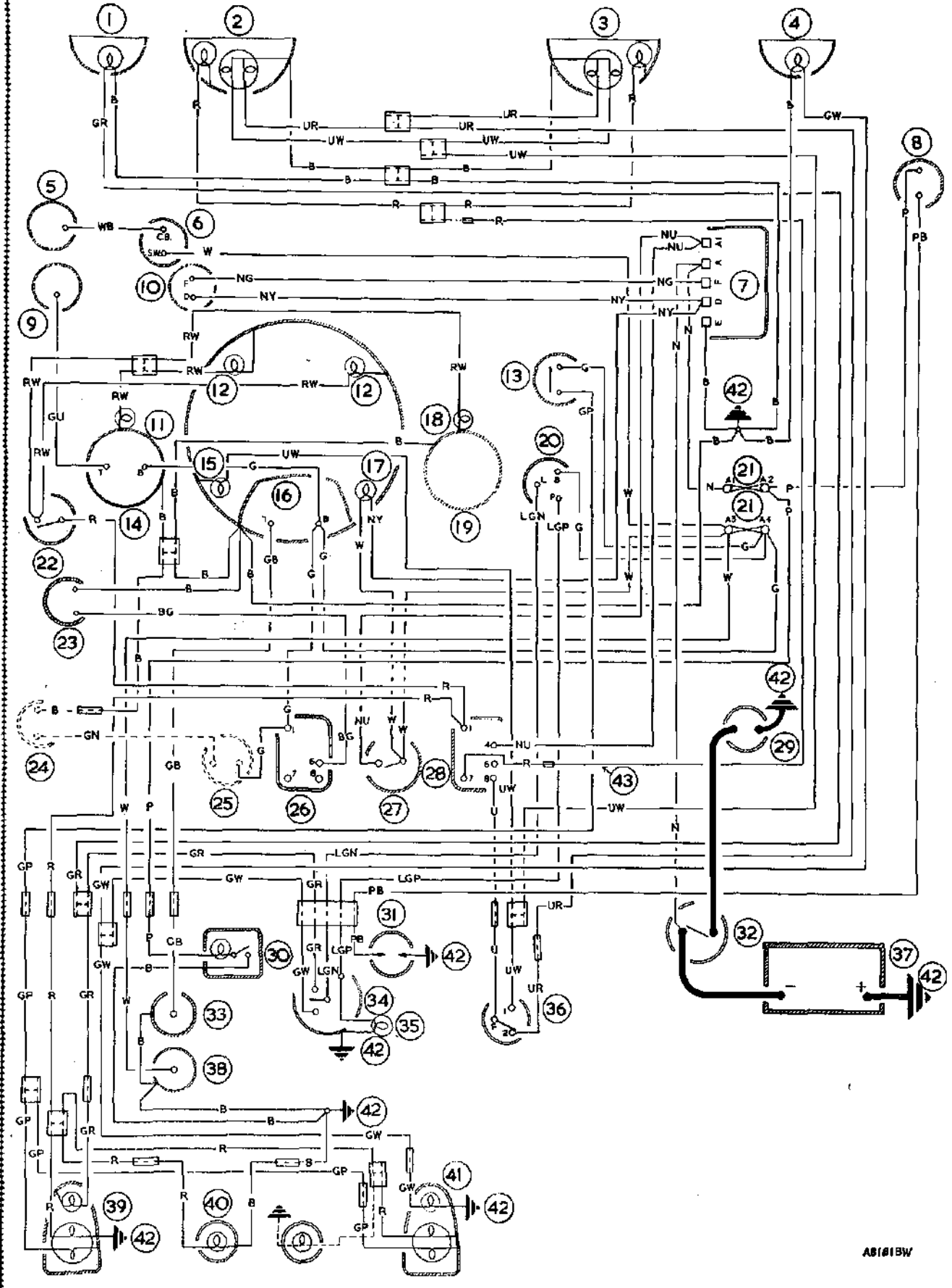

AB181BW

KEY TO WIRING DIAGRAM

| <i>No.</i> | <i>Description</i> | <i>No.</i> | <i>Description</i> |
|------------|----------------------------------|------------|--|
| 1. | L.H. flasher lamp. | 23. | Wiper motor. |
| 2. | L.H. headlamp and pilot lamp. | 24. | Heater motor. |
| 3. | R.H. headlamp and pilot lamp. | 25. | Heater switch. |
| 4. | R.H. flasher lamp. | 26. | Wiper switch. |
| 5. | Distributor. | 27. | Ignition and starter switch. |
| 6. | Ignition coil. | 28. | Lighting switch. |
| 7. | Voltage regulator and cut-out. | 29. | Starter motor. |
| 8. | Horn. | 30. | Interior lamp. |
| 9. | Thermo element. | 31. | Horn-push. |
| 10. | Dynamo. | 32. | Starter solenoid. |
| 11. | Thermo gauge illumination light. | 33. | Tank unit. |
| 12. | Panel illumination lights. | 34. | Direction indicator switch. |
| 13. | Stop lamp switch. | 35. | Direction indicator warning light. |
| 14. | Thermo gauge. | 36. | Dipper switch. |
| 15. | Main-beam warning light. | 37. | 12-volt battery. |
| 16. | Fuel gauge. | 38. | Fuel pump. |
| 17. | Ignition warning light. | 39. | L.H. stop, tail, and flasher lamp. |
| 18. | Oil gauge illumination light. | 40. | Number-plate illumination lamp. |
| 19. | Oil gauge. | 41. | R.H. stop, tail, and flasher lamp. |
| 20. | Flasher unit. | 42. | Earth connection. |
| 21. | 35-amp. fuses. | 43. | Connect to terminal 6 for North America. |
| 22. | Panel lights switch. | | |

NOTE.—On Export models the pilot lamps are combined with the flasher lamps.

CABLE COLOUR CODE

| | | |
|-----------|------------|------------|
| B. Black. | P. Purple. | Y. Yellow. |
| U. Blue. | R. Red. | L. Light. |
| N. Brown. | S. Slate. | M. Medium. |
| G. Green. | W. White. | D. Dark. |

When a cable has two colour code letters the first denotes the main colour and the second denotes the tracer colour.

WIRING DIAGRAM

Standard and De-luxe (up to 1964)

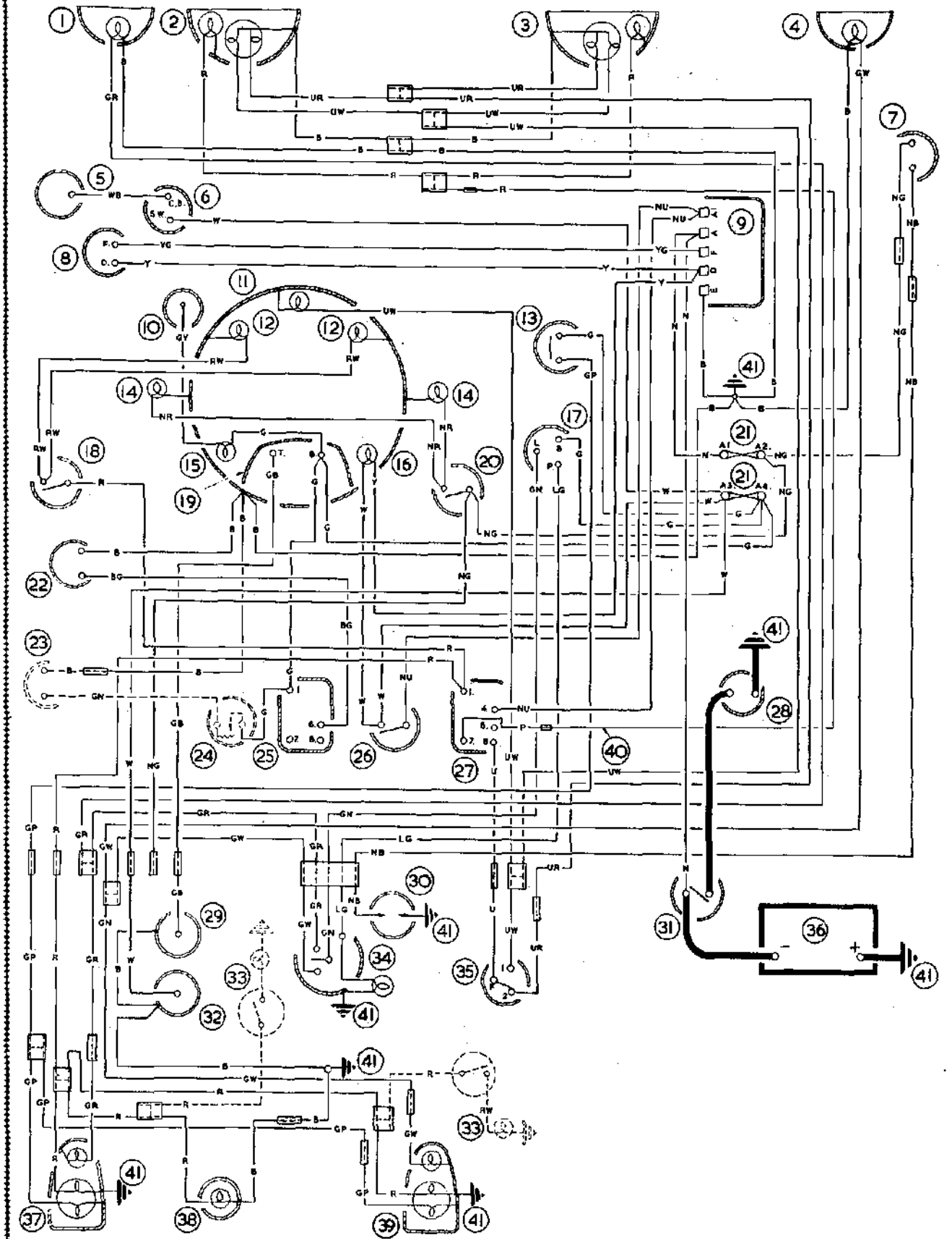

A8307W

KEY TO WIRING DIAGRAM

| <i>No.</i> | <i>Description</i> | <i>No.</i> | <i>Description</i> |
|------------|-----------------------------------|------------|---|
| 1. | L.H. flasher lamp. | 22. | Wiper motor. |
| 2. | L.H. headlamp and pilot lamp. | 23. | Heater motor. |
| 3. | R.H. headlamp and pilot lamp. | 24. | Heater switch. |
| 4. | R.H. flasher lamp. | 25. | Wiper switch. |
| 5. | Distributor. | 26. | Ignition switch. |
| 6. | Ignition coil. | 27. | Lighting switch. |
| 7. | Horn. | 28. | Starter motor. |
| 8. | Dynamo. | 29. | Tank unit. |
| 9. | Voltage regulator and cut-out. | 30. | Horn-push. |
| 10. | Oil pressure switch. | 31. | Starter switch. |
| 11. | Main-beam warning light. | 32. | Fuel pump. |
| 12. | Panel illumination light. | 33. | Companion box switch and lamp. |
| 13. | Stop light switch. | 34. | Direction indicator switch and warning light. |
| 14. | Parcel shelf illumination lamp. | 35. | Dipper switch. |
| 15. | Oil pressure warning light. | 36. | 12-volt battery. |
| 16. | Ignition warning light. | 37. | L.H. stop, tail, and flasher lamp. |
| 17. | Flasher unit. | 38. | Number-plate illumination lamp. |
| 18. | Panel illumination switch. | 39. | R.H. stop, tail, and flasher lamp. |
| 19. | Fuel gauge. | 40. | Connect to No. 6 terminal for U.S.A. |
| 20. | Parcel shelf illumination switch. | 41. | Earth connection. |
| 21. | 35-amp. fuse. | | |

CABLE COLOUR CODE

| | | |
|-----------|------------|------------|
| B. Black. | P. Purple. | L. Light. |
| U. Blue. | R. Red. | D. Dark. |
| N. Brown. | W. White. | M. Medium. |
| G. Green. | Y. Yellow. | |

When a cable has two colour code letters the first denotes the main colour and the second denotes the tracer colour.

KEY TO WIRING DIAGRAM

| <i>No.</i> | <i>Description</i> | <i>No.</i> | <i>Description</i> |
|------------|--|------------|---|
| 1. | Dynamo. | 29. | L.H. front flasher lamp. |
| 2. | Control box. | 30. | R.H. rear flasher lamp. |
| 3. | 12-volt battery. | 31. | L.H. rear flasher lamp. |
| 4. | Starter solenoid. | 32. | Heater switch |
| 5. | Starter motor. | 33. | Heater motor |
| 6. | Lighting switch. | | } when fitted. |
| 7. | Headlamp dip switch. | 34. | Fuel gauge. |
| 8. | R.H. headlamp. | 35. | Fuel gauge tank unit. |
| 9. | L.H. headlamp. | 36. | Windscreen wiper switch. |
| 10. | Main-beam warning lamp. | 37. | Windscreen wiper motor. |
| 11. | R.H. sidelamp (in headlamp or flasher) lamp. | 38. | Ignition/starter switch. |
| 12. | L.H. sidelamp (in headlamp or flasher) lamp. | 39. | Ignition coil. |
| 13. | Panel lamps switch. | 40. | Distributor. |
| 14. | Panel lamps. | 41. | Fuel pump. |
| 15. | Number-plate lamp (two for Van). | 42. | Oil pressure switch. |
| 16. | R.H. stop and tail lamp. | 43. | Oil pressure warning lamp. |
| 17. | L.H. stop and tail lamp. | 44. | Ignition warning lamp. |
| 18. | Stop lamp switch. | 45. | Speedometer. |
| 19. | Fuse unit: 1-2, 35 amp.; 3-4, 35 amp. | 64. | Bi-metal instrument voltage stabilizer. |
| 20. | Interior light. | 83. | Induction heater and thermostat (when fitted). |
| 21. | R.H. door switch. | 84. | Suction chamber heater (when fitted). |
| 22. | L.H. door switch. | 94. | Oil filter switch. |
| 23. | Horn. | 105. | Oil filter warning lamp. |
| 24. | Horn-push. | 115. | Rear window demister switch (when fitted). |
| 25. | Flasher unit. | 116. | Rear window demister unit (when fitted). |
| 26. | Direction indicator switch. | 131. | Combined reverse switch/automatic gearbox switch (when fitted). |
| 27. | Direction indicator warning lamp. | 139. | Connect to No. 6 for U.S.A. (alternative connection). |
| 28. | R.H. front flasher lamp. | 150. | Rear window demister warning light (when fitted). |

CABLE COLOUR CODE

| | | |
|-----------|------------|-------------------|
| B. Black. | G. Green. | W. White. |
| U. Blue. | P. Purple. | Y. Yellow. |
| N. Brown. | R. Red. | L.G. Light Green. |

When a cable has two colour code letters the first denotes the main colour and the second denotes the tracer colour.

WIRING DIAGRAM

Cooper, Cooper 'S', Countryman, Traveller, and Super De-luxe (1964 to 1967)

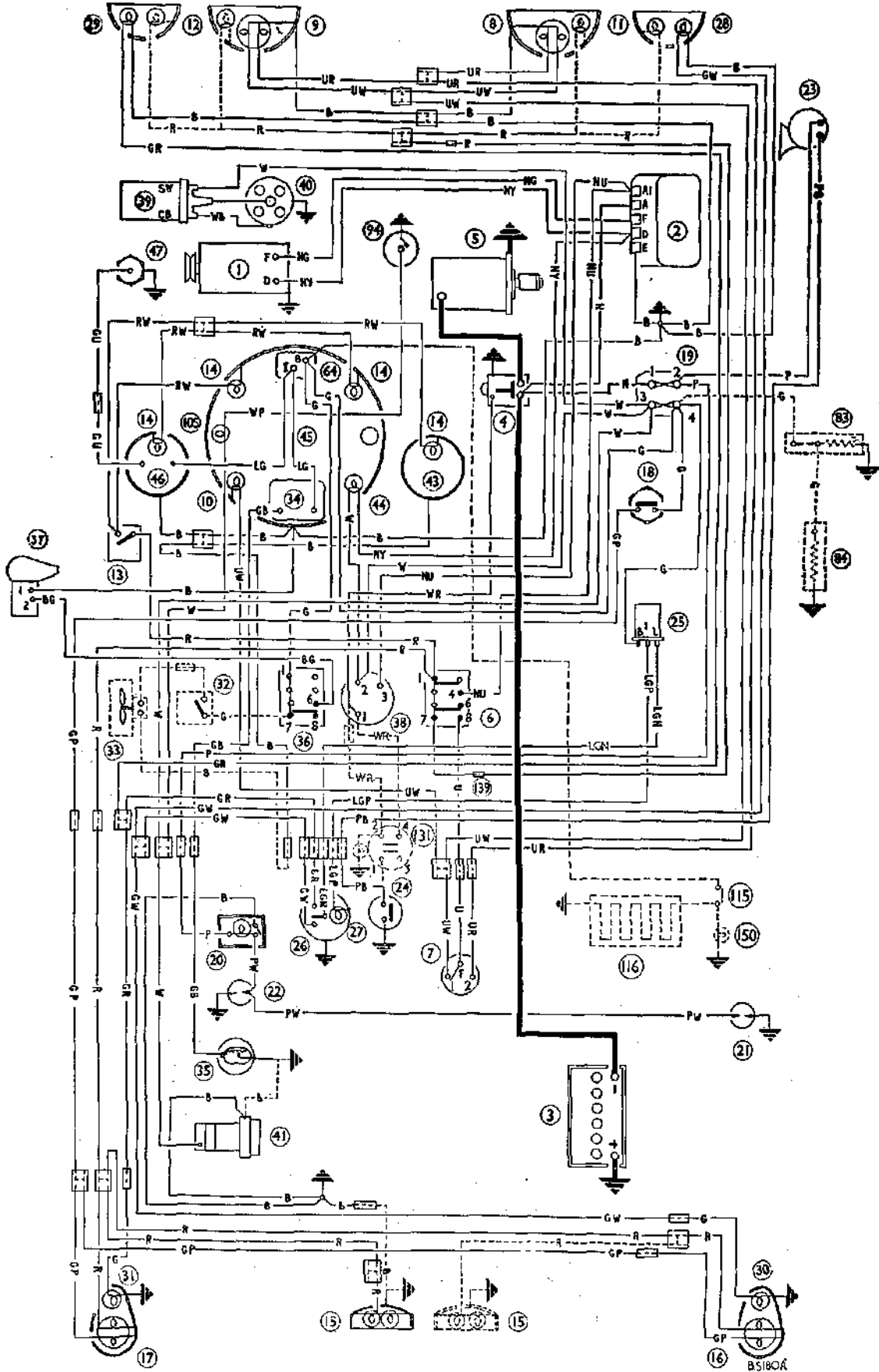

KEY TO WIRING DIAGRAM

| <i>No.</i> | <i>Description</i> | <i>No.</i> | <i>Description</i> |
|------------|---|------------|---|
| 1. | Dynamo. | 30. | R.H. rear flasher lamp. |
| 2. | Control box. | 31. | L.H. rear flasher lamp. |
| 3. | 12-volt battery. | 32. | Heater switch |
| 4. | Starter solenoid. | 33. | Heater motor |
| 5. | Starter motor. | | } when fitted. |
| 6. | Lighting switch. | 34. | Fuel gauge. |
| 7. | Headlamp dip switch. | 35. | Fuel gauge tank unit. |
| 8. | R.H. headlamp. | 36. | Windscreen wiper switch. |
| 9. | L.H. headlamp. | 37. | Windscreen wiper motor. |
| 10. | Main-beam warning lamp. | 38. | Ignition/starter switch. |
| 11. | R.H. sidelamp (in headlamp or flasher) lamp. | 39. | Ignition coil. |
| 12. | L.H. sidelamp (in headlamp or flasher) lamp. | 40. | Distributor. |
| 13. | Panel lamps switch. | 41. | Fuel pump. |
| 14. | Panel lamps. | 42. | Oil pressure switch. |
| 15. | Number-plate lamp (two for Countryman and Traveller). | 43. | Oil pressure warning lamp. |
| 16. | R.H. stop and tail lamp. | 44. | Ignition warning lamp. |
| 17. | L.H. stop and tail lamp. | 45. | Speedometer. |
| 18. | Stop lamp switch. | 46. | Temperature gauge. |
| 19. | Fuse unit: 1-2, 35 amp.; 3-4, 35 amp. | 47. | Temperature gauge transmitter. |
| 20. | Interior light. | 64. | Bi-metal instrument voltage stabilizer. |
| 21. | R.H. door switch. | 83. | Induction heater and thermostat (when fitted). |
| 22. | L.H. door switch. | 84. | Suction chamber heater (when fitted). |
| 23. | Horn. | 94. | Oil filter switch. |
| 24. | Horn-push. | 105. | Oil filter warning lamp. |
| 25. | Flasher unit. | 115. | Rear window demister switch (when fitted). |
| 26. | Direction indicator switch. | 116. | Rear window demister unit (when fitted). |
| 27. | Direction indicator warning lamp. | 131. | Combined reverse switch/automatic gearbox switch (when fitted). |
| 28. | R.H. front flasher lamp. | 139. | Connect to No. 6 for U.S.A. (alternative connection). |
| 29. | L.H. front flasher lamp. | 150. | Rear window demister warning light (when fitted). |

CABLE COLOUR CODE

| | | |
|-----------|------------|-------------------|
| B. Black. | G. Green. | W. White. |
| U. Blue. | P. Purple. | Y. Yellow. |
| N. Brown. | R. Red. | L.G. Light Green. |

When a cable has two colour code letters the first denotes the main colour and the second denotes the tracer colour.

WIRING DIAGRAM Mini-Moke (up to 1967)

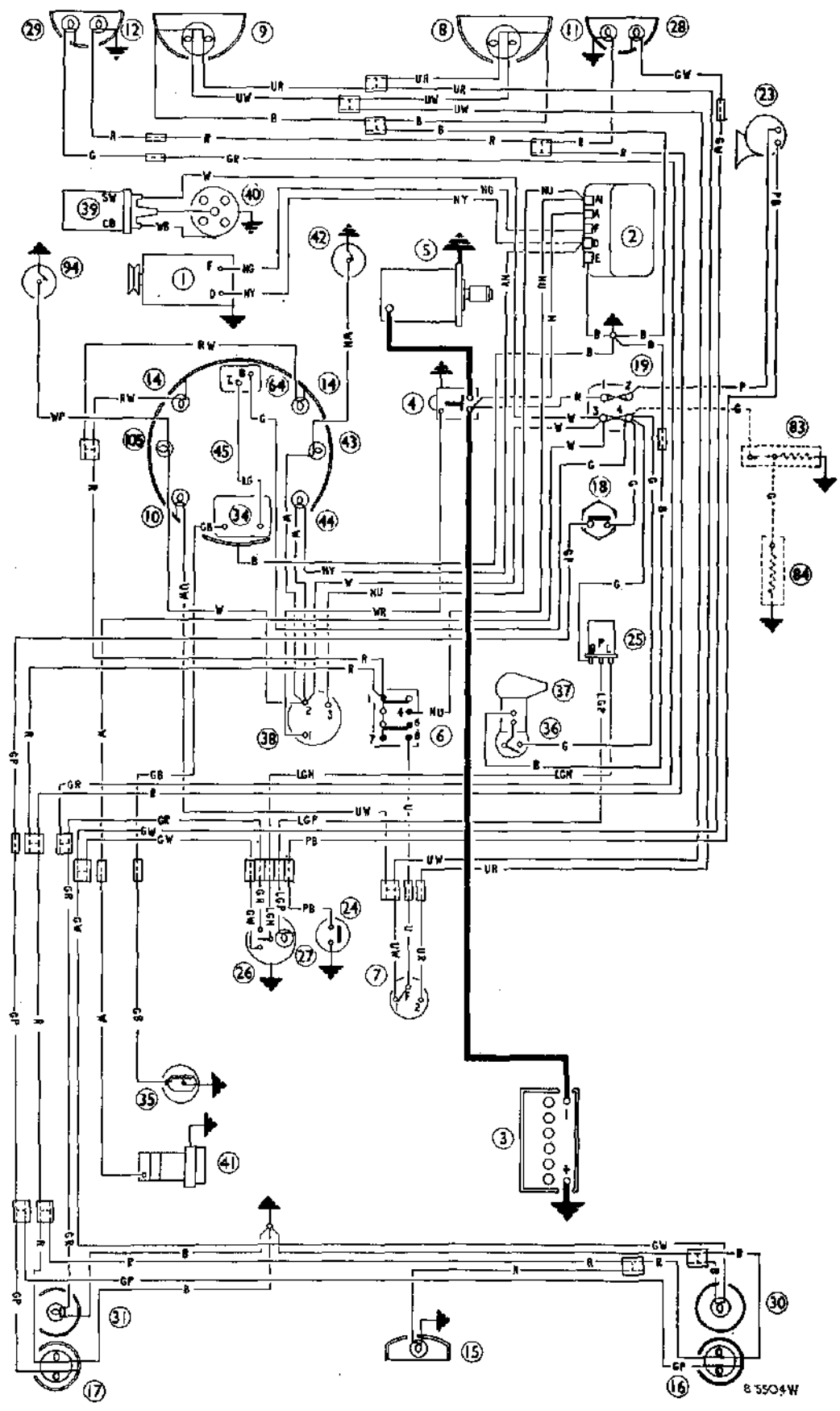

KEY TO WIRING DIAGRAM

| <i>No.</i> | <i>Description</i> | <i>No.</i> | <i>Description</i> |
|------------|--|------------|---|
| 1. | Dynamo. | 27. | Direction indicator warning lamp. |
| 2. | Control box. | 28. | R.H. front flasher lamp. |
| 3. | 12-volt battery. | 29. | L.H. front flasher lamp. |
| 4. | Starter solenoid. | 30. | R.H. rear flasher lamp. |
| 5. | Starter motor. | 31. | L.H. rear flasher lamp. |
| 6. | Lighting switch. | 34. | Fuel gauge. |
| 7. | Headlamp dip switch. | 35. | Fuel gauge tank unit. |
| 8. | R.H. headlamp. | 36. | Windscreen wiper switch. |
| 9. | L.H. headlamp. | 37. | Windscreen wiper motor. |
| 10. | Main-beam warning lamp. | 38. | Ignition starter switch. |
| 11. | R.H. sidelamp. | 39. | Ignition coil. |
| 12. | L.H. sidelamp. | 40. | Distributor. |
| 14. | Panel lamps. | 41. | Fuel pump. |
| 15. | Number-plate illumination lamp. | 42. | Oil pressure switch. |
| 16. | R.H. stop and tail lamp. | 43. | Oil pressure warning lamp. |
| 17. | L.H. stop and tail lamp. | 44. | Ignition warning lamp. |
| 18. | Stop lamp switch. | 45. | Speedometer. |
| 19. | Two-way fuse unit: 1-2, 35 amp.; 3-4, 35 amp. | 64. | Bi-metal instrument voltage stabilizer. |
| 23. | Horn. | 83. | Induction heater and thermostat. |
| 24. | Horn-push. | 84. | Suction chamber heater. |
| 25. | Flasher unit. | 94. | Oil filter switch. |
| 26. | Direction indicator switch. | 105. | Oil filter warning lamp. |

CABLE COLOUR CODE

| | | |
|-----------|------------|-------------------|
| B. Black. | G. Green. | W. White. |
| U. Blue. | P. Purple. | Y. Yellow. |
| N. Brown. | R. Red. | L.G. Light Green. |

When a cable has two colour code letters the first denotes the main colour and the second denotes the tracer colour.

WIRING DIAGRAM

Super De-luxe, Countryman, Traveller, Cooper, and Cooper 'S' Mark II

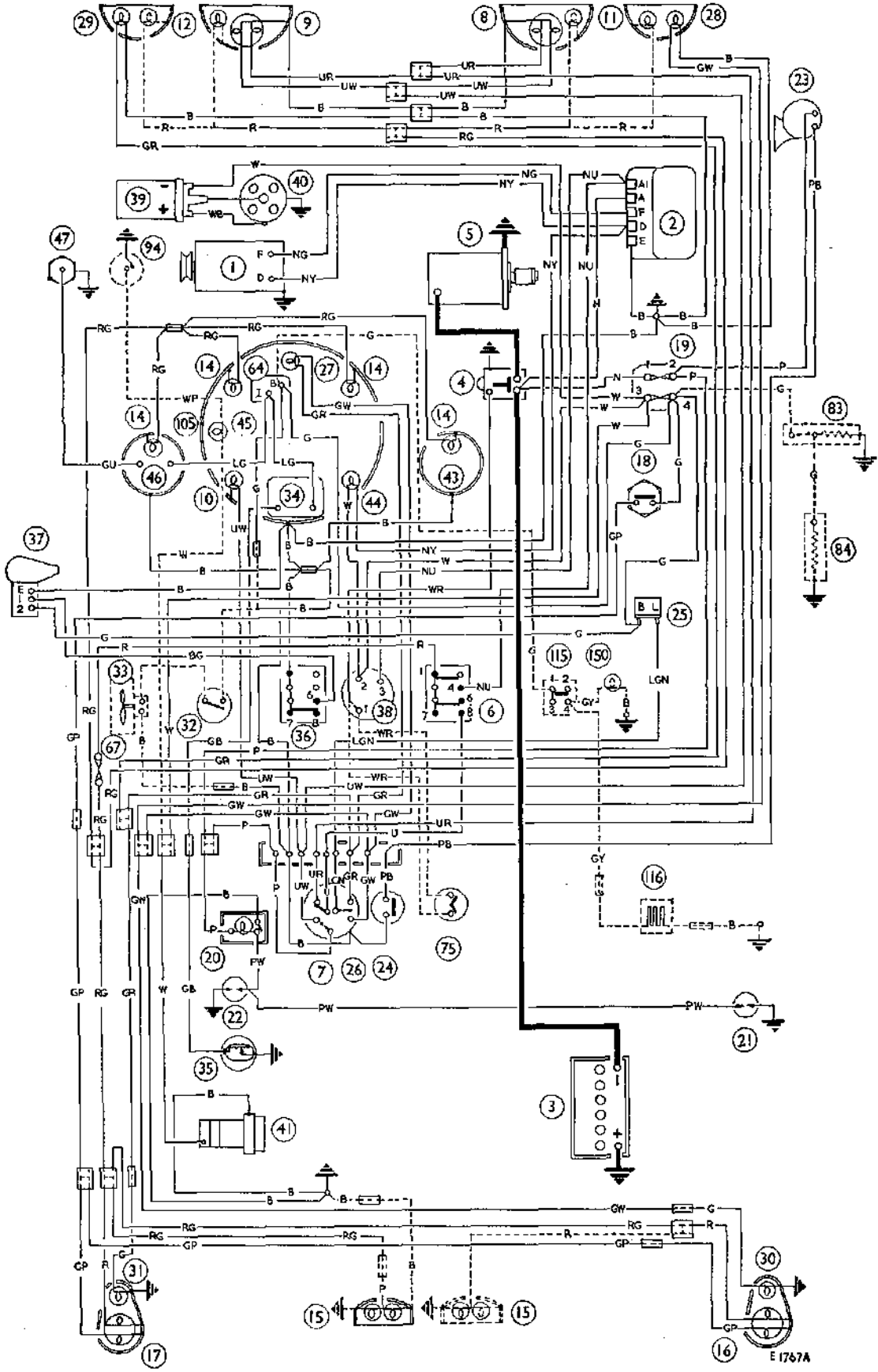

KEY TO WIRING DIAGRAM

| <i>No.</i> | <i>Description</i> | <i>No.</i> | <i>Description</i> |
|------------|---|------------|---|
| 1. | Dynamo. | 30. | R.H. rear flasher lamp. |
| 2. | Control box. | 31. | L.H. rear flasher lamp. |
| 3. | 12-volt battery. | 32. | Heater switch |
| 4. | Starter solenoid. | 33. | Heater motor |
| 5. | Starter motor. | | } when fitted. |
| 6. | Lighting switch. | 34. | Fuel gauge. |
| 7. | Headlamp dip switch. | 35. | Fuel gauge tank unit. |
| 8. | R.H. headlamp. | 36. | Windscreen wiper switch. |
| 9. | L.H. headlamp. | 37. | Windscreen wiper motor. |
| 10. | Main-beam warning lamp. | 38. | Ignition/starter switch. |
| 11. | R.H. sidelamp (in headlamp or flasher) lamp. | 39. | Ignition coil. |
| 12. | L.H. sidelamp (in headlamp or flasher) lamp. | 40. | Distributor. |
| 14. | Panel lamps. | 41. | Fuel pump. |
| 15. | Number-plate lamp (two for Countryman and Traveller). | 42. | Oil pressure switch. |
| 16. | R.H. stop and tail lamp. | 43. | Oil pressure warning lamp. |
| 17. | L.H. stop and tail lamp. | 44. | Ignition warning lamp. |
| 18. | Stop lamp switch. | 45. | Speedometer. |
| 19. | Fuse unit; 1-2, 35 amp.; 3-4, 35 amp. | 46. | Temperature gauge. |
| 20. | Interior light. | 47. | Temperature gauge transmitter. |
| 21. | R.H. door switch. | 64. | Bi-metal instrument voltage stabilizer. |
| 22. | L.H. door switch. | 67. | Line fuse, 35-amp. |
| 23. | Horn. | 75. | Automatic gearbox safety switch (when fitted). |
| 24. | Horn-push. | 83. | Induction heater and thermostat (when fitted). |
| 25. | Flasher unit. | 84. | Suction chamber heater (when fitted). |
| 26. | Direction indicator and headlamp flasher switch. | 94. | Oil filter switch. |
| 27. | Direction indicator warning lamp. | 105. | Oil filter warning lamp. |
| 28. | R.H. front flasher lamp. | | } Not fitted on Automatic. |
| 29. | L.H. front flasher lamp. | 115. | Rear window demister switch (when fitted). |
| | | 116. | Rear window demister unit (when fitted). |
| | | 150. | Rear window demister warning light (when fitted). |

CABLE COLOUR CODE

| | | |
|-----------|------------|-------------------|
| B. Black. | G. Green. | W. White. |
| U. Blue. | P. Purple. | Y. Yellow. |
| N. Brown. | R. Red. | L.G. Light Green. |

When a cable has two colour code letters the first denotes the main colour and the second denotes the tracer colour.

WIRING DIAGRAM

Standard Saloon, Van, and Pick-up Mark II

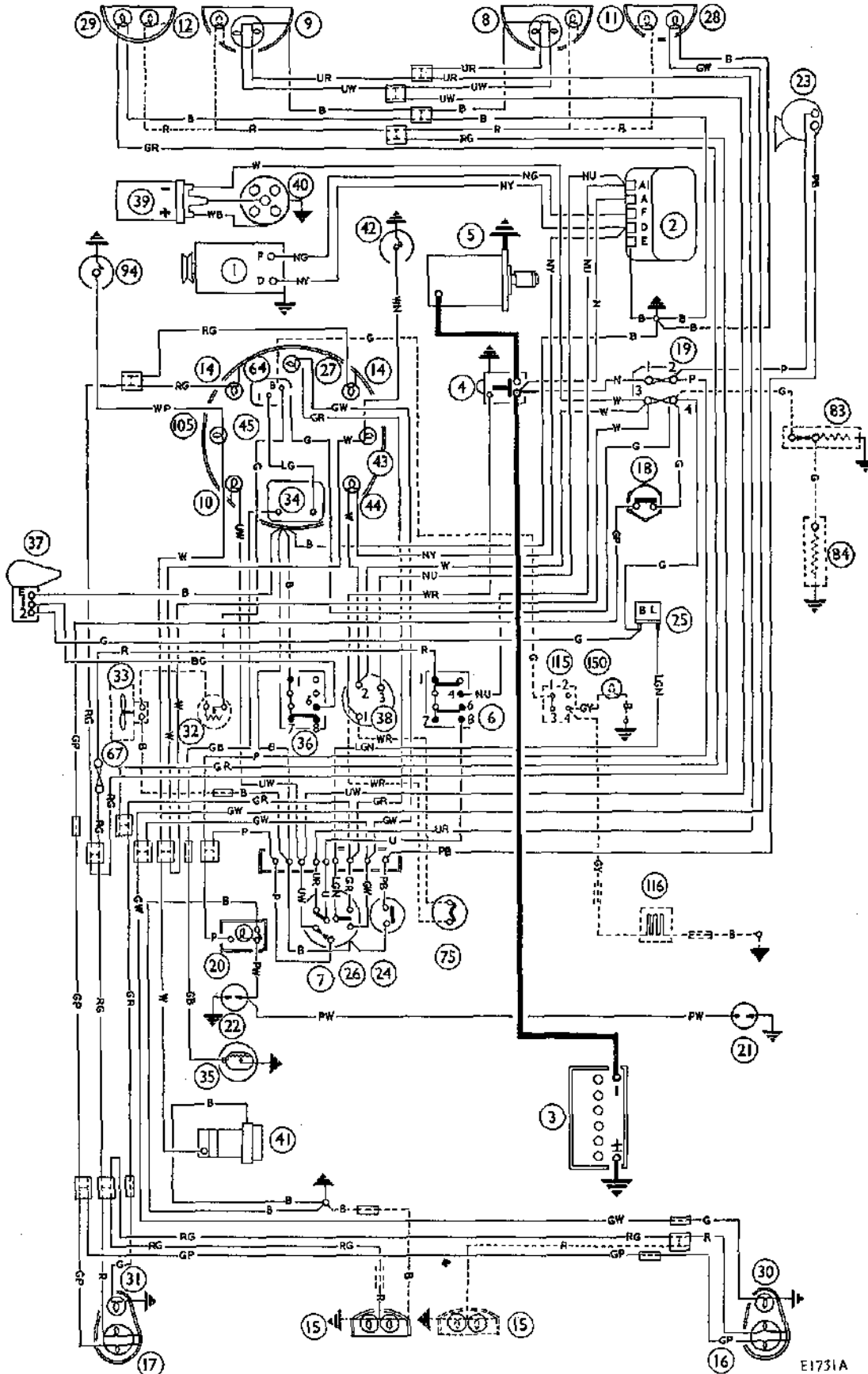

KEY TO WIRING DIAGRAM

| <i>No.</i> | <i>Description</i> | <i>No.</i> | <i>Description</i> |
|------------|--|------------|---|
| 1. | Dynamo. | 29. | L.H. front flasher lamp. |
| 2. | Control box. | 30. | R.H. rear flasher lamp. |
| 3. | 12-volt battery. | 31. | L.H. rear flasher lamp. |
| 4. | Starter solenoid. | 32. | Heater switch |
| 5. | Starter motor. | 33. | Heater motor. |
| 6. | Lighting switch. | | } when fitted. |
| 7. | Headlamp dip switch. | 34. | Fuel gauge. |
| 8. | R.H. headlamp. | 35. | Fuel gauge tank unit. |
| 9. | L.H. headlamp. | 36. | Windscreen wiper switch. |
| 10. | Main-beam warning lamp. | 37. | Windscreen wiper motor. |
| 11. | R.H. sidelamp (in headlamp or flasher) lamp. | 38. | Ignition/starter switch. |
| 12. | L.H. sidelamp (in headlamp or flasher) lamp. | 39. | Ignition coil. |
| 14. | Panel lamps. | 40. | Distributor. |
| 15. | Number-plate lamp (two for Van). | 41. | Fuel pump. |
| 16. | R.H. stop and tail lamp. | 42. | Oil pressure switch. |
| 17. | L.H. stop and tail lamp. | 43. | Oil pressure warning lamp. |
| 18. | Stop lamp switch. | 44. | Ignition warning lamp. |
| 19. | Fuss unit: 1-2, 35 amp.; 3-4, 35 amp. | 45. | Speedometer. |
| 20. | Interior light. | 64. | Bi-metal instrument voltage stabilizer. |
| 21. | R.H. door switch. | 76. | Line fuse, 35-amp. |
| 22. | L.H. door switch. | 75. | Automatic gearbox safety switch (when fitted). |
| 23. | Horn. | 83. | Induction heater and thermostat (when fitted). |
| 24. | Horn-push. | 84. | Suction chamber heater (when fitted). |
| 25. | Flasher unit. | 94. | Oil filter switch. |
| 26. | Direction indicator and headlamp flasher switch. | 105. | Oil filter warning lamp. |
| 27. | Direction indicator warning lamp. | | } Not fitted on Automatic. |
| 28. | R.H. front flasher lamp. | 115. | Rear window demister switch (when fitted). |
| | | 116. | Rear window demister unit (when fitted). |
| | | 150. | Rear window demister warning light (when fitted). |

CABLE COLOUR CODE

| | | |
|-----------|------------|-------------------|
| B. Black. | G. Green. | W. White. |
| U. Blue. | P. Purple. | Y. Yellow. |
| N. Brown. | R. Red. | L.G. Light Green. |

When a cable has two colour code letters the first denotes the main colour and the second denotes the tracer colour.

WIRING DIAGRAM Mini-Moke Mark II

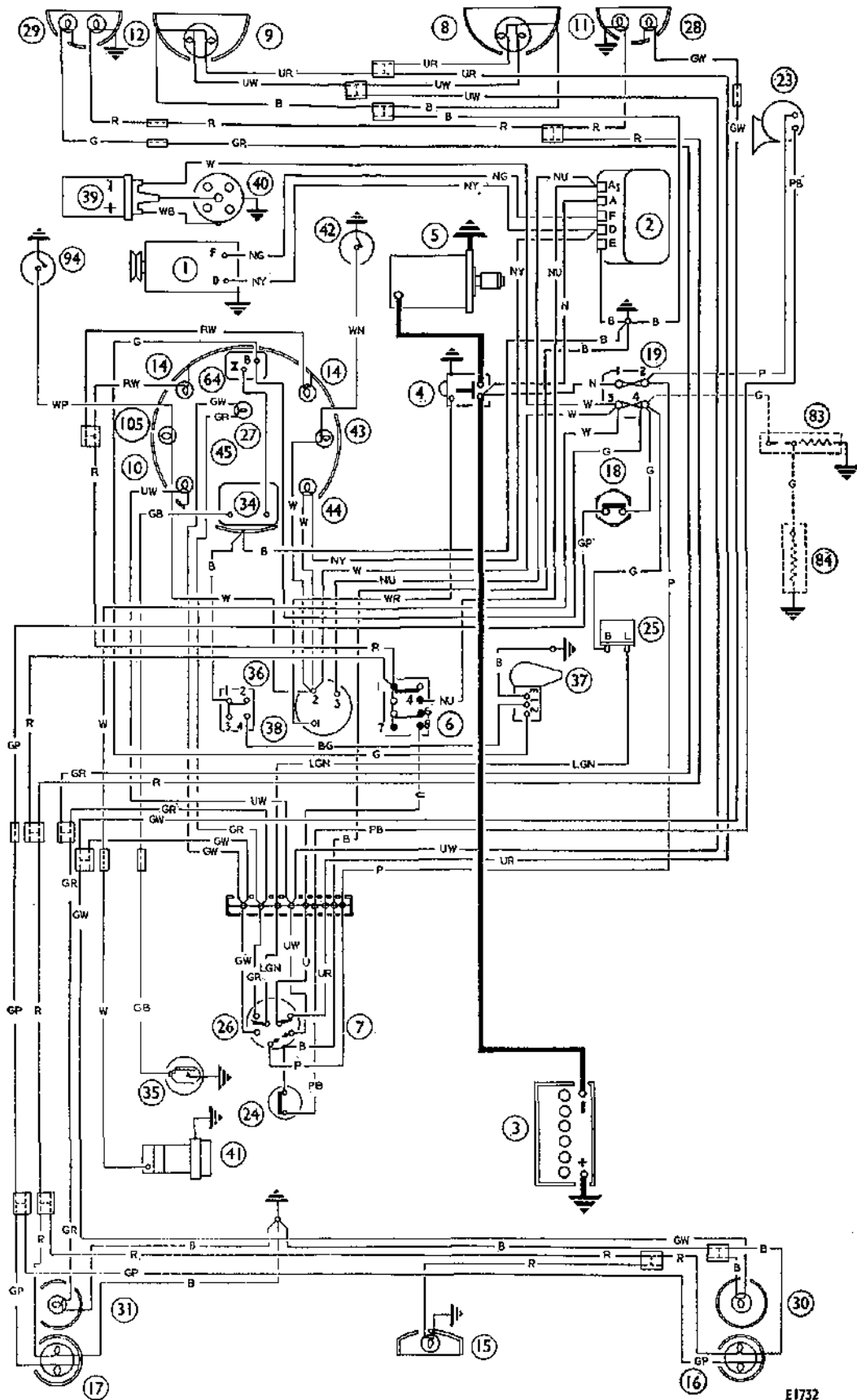

KEY TO WIRING DIAGRAM

| <i>No.</i> | <i>Description</i> | <i>No.</i> | <i>Description</i> |
|------------|---|------------|---|
| 1. | Dynamo. | 27. | Direction indicator warning lamp. |
| 2. | Control box. | 28. | R.H. front flasher lamp. |
| 3. | 12-volt battery. | 29. | L.H. front flasher lamp. |
| 4. | Starter solenoid. | 30. | R.H. rear flasher lamp. |
| 5. | Starter motor. | 31. | L.H. rear flasher lamp. |
| 6. | Lighting switch. | 34. | Fuel gauge. |
| 7. | Headlamp dip switch. | 35. | Fuel gauge tank unit. |
| 8. | R.H. headlamp. | 36. | Windscreen wiper switch. |
| 9. | L.H. headlamp. | 37. | Windscreen wiper motor. |
| 10. | Main-beam warning lamp. | 38. | Ignition starter switch. |
| 11. | R.H. sidelamp. | 39. | Ignition coil. |
| 12. | L.H. sidelamp. | 40. | Distributor. |
| 14. | Panel lamps. | 41. | Fuel pump. |
| 15. | Number-plate illumination lamp. | 42. | Oil pressure switch. |
| 16. | R.H. stop and tail lamp. | 43. | Oil pressure warning lamp. |
| 17. | L.H. stop and tail lamp. | 44. | Ignition warning lamp. |
| 18. | Stop lamp switch. | 45. | Speedometer. |
| 19. | Two-way fuse unit; 1-2, 35 amp.; 3-4, 35 amp. | 64. | Bi-metal instrument voltage stabilizer. |
| 23. | Horn. | 83. | Induction heater and thermostat. |
| 24. | Horn-push. | 84. | Suction chamber heater. |
| 25. | Flasher unit. | 94. | Oil filter switch. |
| 26. | Direction indicator switch. | 105. | Oil filter warning lamp. |

CABLE COLOUR CODE

| | | |
|-----------|------------|-------------------|
| B. Black. | G. Green. | W. White. |
| U. Blue. | P. Purple. | Y. Yellow. |
| N. Brown. | R. Red. | L.G. Light Green. |

When a cable has two colour code letters the first denotes the main colour and the second denotes the tracer colour.

Section N.1

BATTERY

Maintenance

- (1) Keep the battery clean and the vent holes in the caps free.
- (2) Clean corroded terminals with diluted ammonia and smear them with petroleum jelly.
- (3) Maintain the level of the electrolyte just above the tops of the separators.

NOTE.—Disconnect the battery earth cable before boost-charging the battery or using arc welding equipment on the body. Considerable damage to the electrical components will result if the ignition is switched on while the battery remains connected to the car electrical system.

Checking

- (4) The state of charge of the battery is indicated by hydrometer reading as follows:

For climates below 27° C. (80° F.)

| | |
|----------------------------------|----------------|
| Cell fully charged | 1.270 to 1.290 |
| Cell about half-charged | 1.190 to 1.210 |
| Cell completely discharged | 1.110 to 1.130 |

For climates above 27° C. (80° F.)

| | |
|----------------------------------|----------------|
| Cell fully charged | 1.210 to 1.230 |
| Cell about half-charged | 1.130 to 1.150 |
| Cell completely discharged | 1.050 to 1.070 |

These figures are given assuming an electrolyte temperature of 16° C. (60° F.). If the temperature of the electrolyte exceeds this .002 must be added to hydrometer readings for each 3° C. (5° F.) rise to give the true specific gravity. Similarly, .002 must be subtracted from hydrometer readings for every 3° C. (5° F.) below 16° C. (60° F.).

Charging (used battery)

- (5) Charge at 3.0 amps. until all cells are gassing freely and hydrometer readings of each cell have not risen in four hours. Do not allow the temperature of the electrolyte to exceed the following maximum:
For climates below 27° C. (80° F.) 30° C. (100° F.).
For climates above 27° C. (80° F.) 49° C. (120° F.).

Dry-charged batteries

Dry-charged batteries are supplied without electrolyte but with the plates in a charged condition. No initial charging is required.

- (6) Fill with electrolyte obtained as follows:

To obtain specific gravity Add 1 vol. of acid of (corrected to 1.840 S.G. (corrected

| | | |
|---------------------|---------------------------|------------------------------|
| <i>For climates</i> | <i>16° C. [60° F.] of</i> | <i>to 16° C. [60° F.] to</i> |
| <i>Below 27° C.</i> | | |
| <i>(80° F.)</i> | 1.260 | 3.2 volumes of water |
| <i>Above 27° C.</i> | | |
| <i>(80° F.)</i> | 1.210 | 4.3 volumes of water |

Batteries filled in this way are capable of giving a starting discharge one hour after filling. When time permits, however, a short freshening charge at the normal recharge rate (3.0 amps.) will ensure that the battery is fully charged.

During the charge the electrolyte must be kept level with the top edge of the separators by addition of distilled water. Check the specific gravity of the acid at the end of the charge; if 1.260 acid was used to fill the battery, the specific gravity should now be between 1.270 and 1.290. If 1.210 acid was used the specific gravity should now be between 1.210 and 1.230. After filling, a dry-charged battery needs only the attention normally given to a lead-acid battery.

New, unfilled, uncharged battery

- (7) Half fill each cell with electrolyte prepared as in item (6) above and allow it to stand for six hours, fill each cell to the correct level and allow a further standing period of two hours.
- (8) Charge at 2 amps. until five successive hourly hydrometer checks show no increase in the reading; this will take from 48 to 80 hours, depending on the length of time the battery has been stored before charging. This charge should not be broken by long rest periods.
- (9) If the temperature of any cell rises above the maximum given in (5), the charge must be interrupted until the temperature has fallen at least 5.5° C. (10° F.) below that figure.
- (10) Maintain the level of the electrolyte during the charge.
- (11) At the end of the charge carefully check the specific gravity in each cell to ensure that, when corrected to 16° C. (60° F.) it lies between the specified limits. If any cell requires adjustment some of the electrolyte must be siphoned off and replaced either by distilled water or by acid of strength originally used for filling in, depending on whether the specific gravity is too high or too low. Continue the charge for an hour or so to ensure adequate mixing of the electrolyte and again check the specific gravity readings. If necessary, repeat the adjustment process until the desired reading is obtained in each cell.
- (12) Finally, allow the battery to cool, and siphon off any surplus electrolyte.

Section N.2

DYNAMO

Removing

- (1) Disconnect the leads, slacken the four mounting bolts, remove the fan belt from the pulley, take out the two upper and one lower mounting bolts and lift off the dynamo.

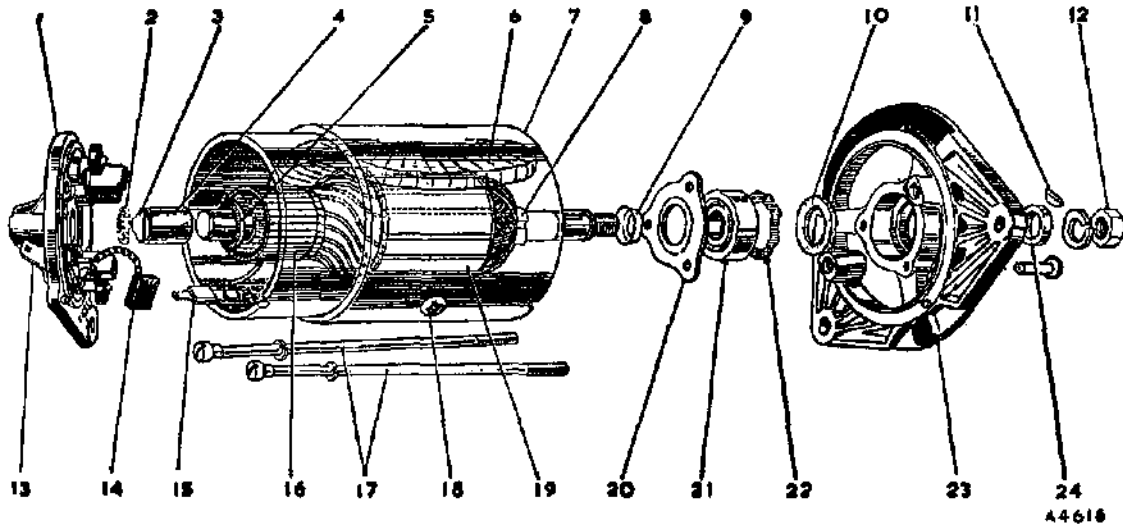

Fig. N.1
The CA0/1 type dynamo

- | | | |
|----------------------------|--------------------------------|--------------------------------|
| 1. Commutator end bracket. | 9. Shaft collar retaining cup. | 17. Through-bolts. |
| 2. Felt ring. | 10. Felt ring. | 18. Pole-shoe securing screws. |
| 3. Felt ring retainer. | 11. Shaft key. | 19. Armature. |
| 4. Bronze bush. | 12. Shaft nut. | 20. Bearing retaining plate. |
| 5. Thrust washer. | 13. Output terminal 'D'. | 21. Ball bearing. |
| 6. Field coils. | 14. Brushes. | 22. Corrugated washer. |
| 7. Yoke. | 15. Field terminal 'F'. | 23. Driving end bracket. |
| 8. Shaft collar. | 16. Commutator. | 24. Pulley spacer. |

Dismantling

- (2) Unscrew the nut and take off the pulley.
- (3) Extract the key from the shaft.
- (4) Withdraw the two through-bolts and remove the commutator end bracket.
- (5) Lift the driving end bracket with the armature and bearing out of the yoke.
- (6) To remove the bearing, press off the end bracket.

Servicing

Brushes

- (7) Clean the brushes with petrol (fuel) and, if sticking, polish them lightly with a smooth file.
- (8) Test the spring tension ('GENERAL DATA').
- (9) Fit new brushes if the existing ones are worn to a length of less than $\frac{1}{4}$ in. (6.5 mm.).

Commutator

- (10) Clean with petrol (fuel) and cloth or polish with fine glass-paper. If it is in very poor condition it may be skimmed to a minimum diameter of 1.450 in. (37 mm.). The undercut must have the following dimensions:
 Width040 in. (1.02 mm.)
 Depth020 to .035 in. (.51 to .89 mm.).

Clean the insulating material from the sides of the undercut to a minimum depth of .015 in. (.38 mm.).

Field coil replacement

- (11) Mark the position of the pole-shoes relative to the yoke.

- (12) Withdraw the pole-shoe securing screws (Fig. N.1), draw the shoes and coils from the yoke and remove the coils from the shoes.
- (13) Fit new coils to the shoes and refit them to the yoke with the shoes in their original positions. Refit the insulating piece at the junction of the coil windings, insert the screws, press the shoes in place with an expander, and tighten the screws (Fig. N.1).

Armature

- (14) If special equipment is not available, test the armature by substitution.

Bearings

- (15) Screw a $\frac{3}{8}$ in. (15.8 mm.) tap into the bush at the commutator end, pull out the bush and fit a new one, using a shouldered mandrel.

NOTE.—Soak the new bush in thin engine oil for 24 hours before fitting.

- (16) Renew the bearing at the driving end as follows:
- (17) Knock out the rivets and remove the bearing retaining plate.
- (18) Press the bearing out of the bracket and remove the corrugated and felt washers.
- (19) Pack the new bearing with grease before pressing it in.

Reassembling and refitting

- (20) Reverse the removing and dismantling instructions.
- (21) The two upper fixing bolts must be fitted with a flat washer under the head of each bolt to register against the dynamo attachment points.

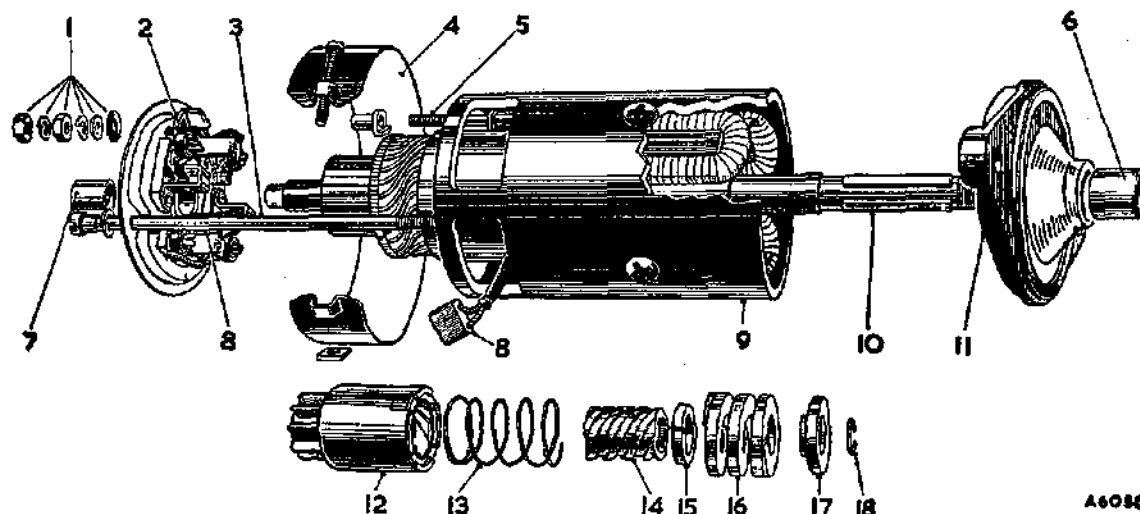

Fig. N.2

An exploded view of the starter motor and drive

- | | | |
|-------------------------------|--------------------------|-------------------------|
| 1. Terminal nuts and washers. | 7. Bearing. | 13. Restraining spring. |
| 2. Brush spring. | 8. Brushes. | 14. Sleeve. |
| 3. Through-bolt. | 9. Yoke. | 15. Impact washer. |
| 4. Band cover. | 10. Armature shaft. | 16. Main spring. |
| 5. Terminal post. | 11. Driving-end bracket. | 17. Locating washer. |
| 6. Bearing bush. | 12. Pinion assembly. | 18. Circlip. |

Section N.3

STARTER

Removing

- (1) Disconnect the cable, unscrew the three bolts and lift away.

Dismantling

- (2) Remove the cover band, withdraw the brushes, unscrew the through-bolts and take out the armature complete with drive.

Servicing

Brushes

See Section N.2, items (7) to (9).

Drive

- (3) If the pinion is tight on the sleeve, wash it in kerosene.
- (4) To dismantle, remove the shaft nut and withdraw the main spring and collar. On later types, compress the spring and remove the circlip.
- (5) Rotate the barrel, push out the sleeve and remove the barrel and pinion.
- (6) The barrel and pinion are supplied as an assembly.

Commutator

- (7) If cleaning is not effective, skim lightly removing the absolute minimum amount of metal. Do not undercut the mica.

N.20

Field coils

See Section N.2, items (11), (12), and (13).

Bearing

See Section N.2, item (15).

Armature

See Section N.2, item (14).

Reassembling and refitting

Reverse the removal and dismantling instructions.

Section N.4

VOLTAGE REGULATOR

Adjusting (cold unit)

Electrical

- (1) Disconnect the cables from the control box terminals 'A' and 'A1' and join them together.
- (2) Connect the negative lead from a voltmeter (0-20 volts) to control box terminal 'D' and the positive lead to terminal 'E'.
- (3) Slowly increase engine speed until the voltmeter needle flicks and then steadies. This should occur between 15.8 and 16.7 volts, depending on the ambient temperature.
- (4) If adjustment is required, switch off the engine and remove the control box cover.

- (5) Turn the voltage adjustment screw (1) (Fig. N.3), in a clockwise direction to raise the voltage and anti-clockwise to lower it. Turn only a fraction of a turn at a time. This adjustment should be completed within 30 seconds or the settings will be affected by heat. Do not run the dynamo at a higher speed than is necessary for the adjustment to be made.

Mechanical

- (6) Slacken the fixed contact and voltage adjusting screws until they are clear of the moving contact and the tension spring respectively. Slacken the two armature assembly securing screws.
- (7) Insert a .021 in. (.53 mm.) feeler gauge between the armature and the core shim. Press the armature squarely down against the gauge and tighten the armature assembly securing screws.
- (8) With the gauge still in position, screw the adjustable contact down until it just touches the armature contact. Tighten the locking nut.
- (9) Reset the voltage adjusting screw as in item (5).

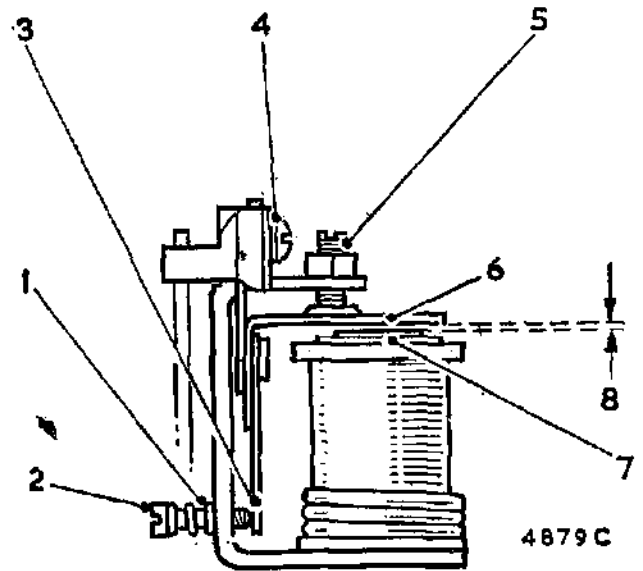

Fig. N.4

Mechanical setting of the regulator

- | | |
|------------------------------|------------------------------------|
| 1. Locknut. | 5. Fixed contact adjustment screw. |
| 2. Voltage adjusting screw. | 6. Armature. |
| 3. Armature tension spring. | 7. Core face and shim. |
| 4. Armature securing screws. | 8. .021 in. (.533 mm.). |

Section N.5

CUT-OUT

Adjustment

Electrical

- (1) To check, connect the voltmeter between terminals 'D' and 'E'. Start the engine and slowly increase the speed until the contacts close; this should occur at 12.7 to 13.3 volts.
- (2) To adjust, turn the adjusting screw clockwise to raise the voltage and anti-clockwise to reduce it. Turn only a fraction at a time. Make the adjustments as quickly as possible to avoid temperature effects.

Mechanical

- (3) Unscrew the cut-out adjusting screw until it is clear of the armature tension spring. Slacken the armature securing screws.
- (4) Press the armature down against the copper-sprayed core and tighten the securing screws.
- (5) Bend the armature stop arm until the gap between it and the tongue is .030 in. (.76 mm.) when the armature is pressed squarely against the core face (8) (Fig. N.6).
- (6) Bend the fixed contact blade so that there is a gap of .010 to .020 in. (.25 to .50 mm.) between the contact points when the armature is free.
- (7) Reset the cut-out adjusting screw.

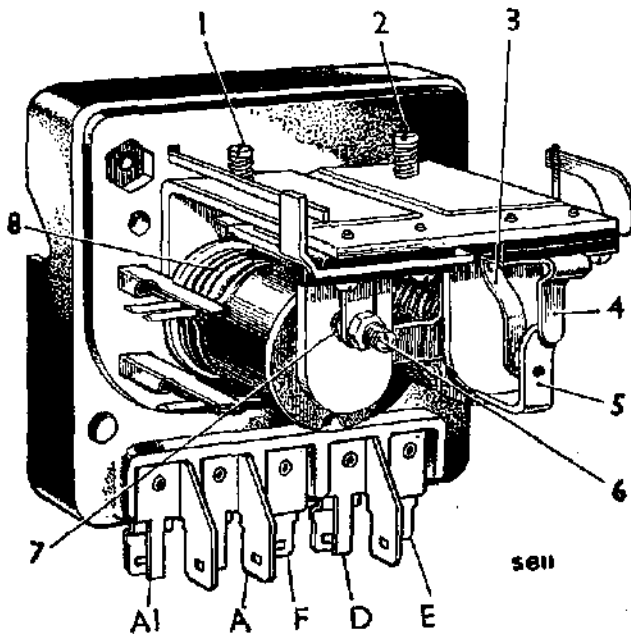
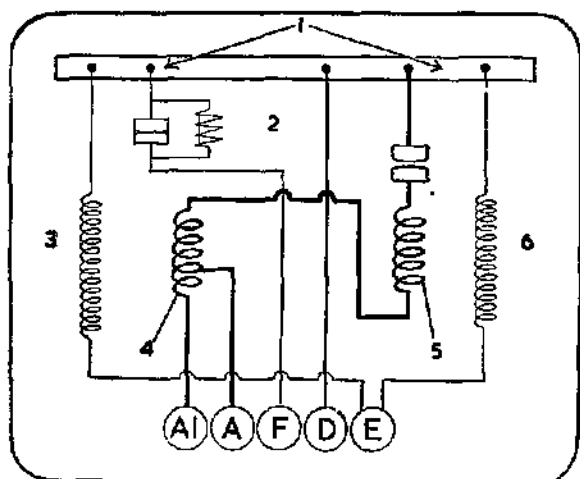

Fig. N.3

The control box

- | | |
|-------------------------------|--|
| 1. Regulator adjusting screw. | 5. Armature tongue and moving contact. |
| 2. Cut-out adjusting screw. | 6. Regulator fixed contact screw. |
| 3. Fixed contact blade. | 7. Regulator moving contact. |
| 4. Stop arm. | 8. Regulator series windings. |



4876A

Fig. N.5

The control box (regulator and cut-out) internal connections

- | | |
|---------------------------------|------------------------|
| 1. Regulator and cut-out frame. | 4. Tapped series coil. |
| 2. Field resistance. | 5. Series coil. |
| 3. Shunt coil. | 6. Shunt coil. |

Section N.6

LAMPS

Full details of the lamps, bulbs, warning lights, etc., are given in the Driver's Handbook.

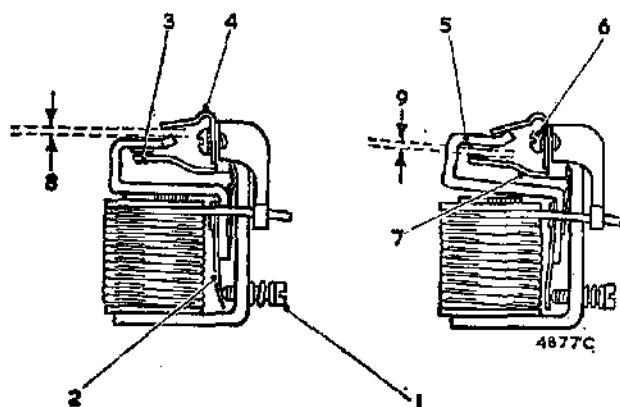

4877C

Fig. N.6

Mechanical setting of the cut-out

- | | |
|--|--|
| 1. Cut-out adjusting screw. | 5. Armature tongue and moving contact. |
| 2. Armature tension spring. | 6. Armature securing screws. |
| 3. 'Follow through'—010 to 020 in. (-25 to -51 mm.). | 7. Fixed contact blade. |
| 4. Stop arm. | 8. 030 in. (-76 mm.). |
| | 9. 010 to 020 in. (-25 to -51 mm.). |

Section N.7

BI-METAL RESISTANCE INSTRUMENTATION

General description

The bi-metal resistance equipment for fuel and temperature gauges consists of an indicator head and transmitter unit connected to a common voltage stabilizer. In both applications the indicator head operates on a thermal principle, using a bi-metal strip surrounded by a heated winding, and the transmitter unit is of a resistance type. The system by which the equipment functions is voltage-sensitive and the voltage stabilizer, which serves one or more gauges, is necessary to ensure a constant supply of a pre-determined voltage to the equipment.

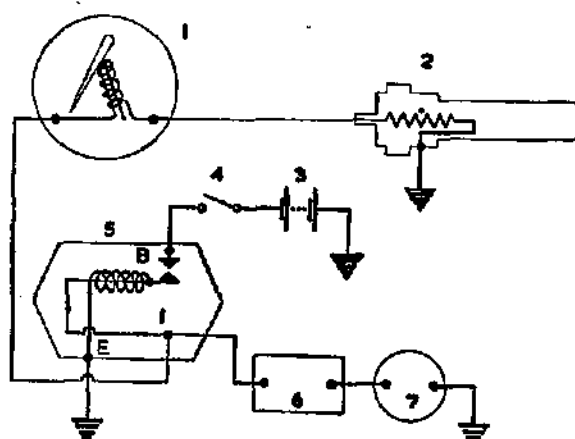

A 9549

Fig. N.7

The bi-metal resistance instrumentation circuit

- | | |
|-----------------------------------|----------------------------|
| 1. Temperature gauge. | 4. Ignition switch. |
| 2. Temperature gauge transmitter. | 5. Voltage stabilizer. |
| 3. Battery. | 6. Fuel gauge. |
| | 7. Fuel gauge transmitter. |

Fault analysis

Voltage stabilizer

Check the mean voltage between the output terminal 'T' and earth, which should be 10 volts.

Substitute voltage stabilizer if faulty.

Gauges

Check for continuity between the terminals with the wiring disconnected. The gauges must not be checked by short circuiting to earth.

Substitute the gauge if faulty.

Transmitter

Check for continuity between terminal and case with lead disconnected.

Substitute transmitter if faulty.

Wiring

Check for continuity between each unit. Check for leak to earth. Check for short circuits to earth on wiring to each transmitter. Check terminal wiring for security, earth connections, and wiring continuity. Check that the voltage stabilizer and relating transmitters are earthed.

NOTE.—If the voltage stabilizer is removed it is essential to ensure that, when replacing, B and E are uppermost and not exceeding 20 degrees from the vertical.

Section N.8

**WINDSCREEN WIPER MOTOR
(Moke)**

The wiper motor fitted to early models of this vehicle operated a single wiping blade on the driver's side only.

Later vehicles are equipped with a motor which operates twin wiper blades, and this motor will be referred to below as the (later type).

Removing (early type)

- (1) Slacken the hexagon screw and pull the blade and arm from the drive spindle.
- (2) Remove the nuts, locknuts, washers, and seals securing the motor to the scuttle.
- (3) Disconnect the leads from inside the vehicle and withdraw the motor.

NOTE.—A rubber flange with steel inserts is fitted between the wiper motor and the scuttle to prevent the insulating flange being over-compressed.

Refitting

- (4) Reverse the removal sequence.

Removing (later type)

- (5) Remove the four nuts securing the rack to the wheelboxes.
- (6) Disconnect the electrical connections from the motor.
- (7) Remove the three screws securing the motor to the bracket and remove the assembly.
- (8) Remove the gearbox cover and withdraw the retaining circlip from the cross-head connecting link pin and lift off the connecting link and rack cable assembly.

Dismantling the motor (later type)

- (9) Remove the through-bolts and the commutator housing.
- (10) Lift the brush unit clear of the commutator and withdraw it. Note the position occupied by each brush so that it may be refitted in its original setting on the commutator.
- (11) Access to the armature and field coils is obtained by withdrawing the yoke.
- (12) Clean the commutator and brushes, replacing any that are worn. Ensure that the commutator segments are clean; short-circuiting of adjacent

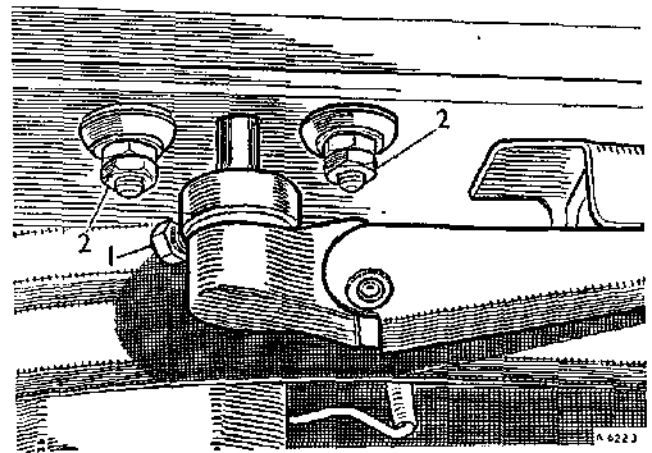
**Fig. N.8****The windscreen wiper (Moke)**

1. Arm-locating screw.
2. Motor mountings.

segments will cause excessive current consumption. The resistance between segments should be $\cdot 29$ to $\cdot 35$ ohms.

Dismantling the gearbox

- (13) Carry out instruction (8).
- (14) Remove the circlip and washer from the final drive gear shaft located underneath the gearbox casing, and lift out the final drive gear.
- (15) The armature can now be withdrawn for cleaning or replacement.
- (16) Examine the worm drive of the armature and the teeth of the final drive gear and fit replacements if either are damaged or excessively worn.

Reassembling

- (17) Reverse the dismantling procedures, using the following lubricants:
Use Ragosine Listate grease liberally on the cross-head, guide channel, connecting rod assembly, worm drive, and on the rack cable and wheelbox assemblies.
Use S.A.E. 20 oil sparingly on the armature and final drive gear bearings.
- (18) Ensure that the plain steel washer is placed beneath the connecting rod when assembling the final drive gear crankpin.
- (19) The armature end-float adjusting screw should be set to allow an end-float of $\cdot 008$ to $\cdot 012$ in. ($\cdot 2$ to $\cdot 3$ mm); this is approximately a quarter of a turn clear of the armature thrust pad.

Refitting

- (20) Reverse the removing procedure, but before switching on the motor remove the wiper arms from the spindles. Switch on the motor and stop it at the end of the stroke; refit the arms so that they are in the correct parking position.

Section N.9

WINDSCREEN WIPER WHEELBOXES

Removing

- (1) Withdraw the wiper arms from the wheelbox spindles, and remove the external securing nuts.
- (2) *All models except Moke.* From under the bonnet, slacken the nut securing the rack to the motor. Swivel the wheelboxes through into the engine compartment sufficiently to enable the securing nuts to be removed and release the wheelbox from the rack and cable. Note the location of the flared ends of the Bundy tubing with each wheelbox.
- (3) *Moke.* Removing is similar to item (2) except that the wheelboxes are located inside the vehicle.

Refitting

- (4) Reverse the removing procedure and fit new external sealing grommets if required. Tighten the rack securing nut on the motor.
- (5) Switch on the motor and stop it at the end of the stroke. Ensure that the arms are correctly positioned to give maximum wipe area and park at the end of the stroke.

Section N.10

ALTERNATOR SERVICE PRECAUTIONS

The following precautions must be observed when dealing with vehicles fitted with an alternator.

- (1) When fitting a replacement alternator ensure that it is of the same polarity as the original. Terminal polarity is clearly marked.
- (2) Do not reverse the battery connections. This will damage the alternator rectifiers. Connect up the earth terminal of the battery first.
- (3) If a high-rate battery charger is used to charge the battery in position in the vehicle, damage will occur to the regulator if the ignition/starter switch is switched on to the auxiliary position. Detach the connectors from the regulator as a safety measure before boost-charging. Re-connect after charging.
- (4) When starting an engine with the aid of a high-rate charger, detach the connectors from the regulator prior to using the charger. Do not re-connect the regulator until the charger is disconnected, and the engine is running at idling speed.
- (5) The battery must never be disconnected while the engine is running, nor must the alternator be run with the main output cable disconnected either at the alternator end or the battery end.
- (6) The cable connecting the battery and alternator is 'live' even when the engine is not running. Take care not to earth the alternator terminal or the cable end if removed from the terminal.

Do not make or break any connections in the alternator circuit while the engine is running.

- (7) Disconnect the alternator and regulator as a safety precaution when arc-welding on the vehicle.

Section N.11

TESTING THE ALTERNATOR CHARGING CIRCUIT IN POSITION

Before commencing the charging circuit tests given below carry out the 'Maintenance' instructions.

Maintenance

The driving belt must be tensioned so that a deflection of $\frac{1}{2}$ in. (13 mm.) can be obtained under finger pressure at the mid-point of the longest run of the belt.

DO NOT apply leverage to any point of the alternator other than the drive end bracket, or run the engine with the battery or alternator disconnected.

Keep the ventilating holes in the slip-ring end cover clean.

Alternator charging circuit

The following procedure should be adopted to locate a fault in the charging circuit using the test equipment recommended below.

Test equipment required

- (a) Moving-coil D.C. ammeter, accurate up to at least 60 amps.
- (b) Moving-coil D.C. voltmeter, scale 0-30 volts (plus one of low range if possible).
- (c) Ohmmeter—battery powered. Hand-driven generator type must never be used for testing diodes.

Testing

- (1) Check the driving belt for wear and tension (see 'Maintenance').
- (2) Check that the battery voltage is reaching the brush gear by disconnecting the two cables from the alternator field terminals, connect a voltmeter between the two cables and run the engine. The voltmeter should register battery voltage. If no reading is obtained, check the field circuit wiring.
- (3) Check alternator output.

Stop the engine and disconnect the battery earth cable (-). If an ammeter is not fitted, disconnect both connectors from the alternator main output terminal 'B' and connect up a moving-coil ammeter between the terminal and the connectors.

Withdraw the cables from the alternator field terminals and connect a pair of auxiliary cables direct between these terminals and the battery (Fig. N.9).

Re-connect the battery earth lead (-). Start the engine and gradually increase speed until the alternator is rotating at 4,000 r.p.m. At this speed the ammeter reading should be approximately 40 amps.

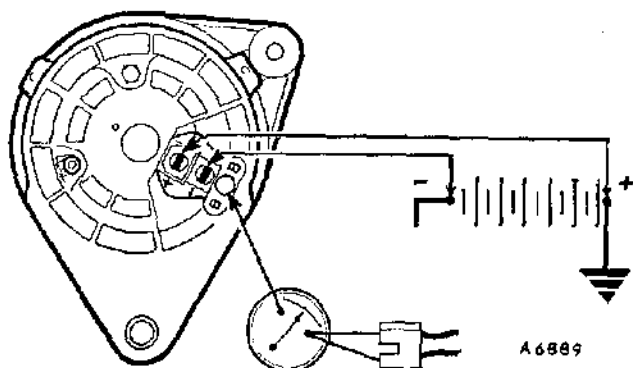

Fig. N.9

Alternator output test connections

- (a) Zero reading: Stop the engine. Remove and inspect the brush gear (see 'Inspection'). Fit new brush gear if necessary and retest. If zero reading persists, remove and dismantle the alternator for detailed inspection.

- (b) Low reading: Indicates either a faulty alternator or poor wiring circuit connections.

Stop the engine and check the wiring connections. Connect a voltmeter (low range) between the alternator output terminal 'B' and the battery negative (—) terminal, restart the engine and note the reading. Transfer the voltmeter connections to the alternator frame and the battery earth (+) terminal and note the reading.

If either reading exceeds .5 volt there is high resistance in the charging circuit which must be traced and remedied. Should the test show no undue resistance (although output is low) proceed to dismantle and inspect the alternator.

- (5) Remove the through-bolts and detach the drive end bracket and rotor.

The drive end bracket and rotor need not be separated unless the drive end bearing requires examination or the rotor is to be replaced. Remove the rotor from the drive end bracket by means of a hand press having first removed the shaft key and bearing collar.

- (6) Remove the terminal nuts, brush box retaining screws, and the heat sink bolt. Withdraw the stator and heat sink from the slip-ring end bracket.
- (7) Close the retaining tongues on the brush terminal blades and withdraw the terminals from the brush box.

Inspection

Brush gear

Brushes worn below $\frac{5}{16}$ in. (8 mm.) should be replaced.

- (a) The new brush complete with spring and 'Lucar' terminal blade is pushed into the holder until the tongue registers. To retain the terminal, carefully lever up the retaining tongue with a thin blade.
- (b) Check that the brushes move freely in their holders. If sluggish, clean brush sides with a petrol-moistened cloth or, if ineffective, lightly polish brush sides with a smooth file. Clean off and re-house.

Slip-rings

Surfaces should be smooth and free of oil or other foreign matter. Clean the surfaces if necessary, using a petrol-moistened cloth or, if there is evidence of burning, very fine glass-paper.

NOTE.—Do not attempt to machine the slip-rings.

Testing

Test equipment required:

- (a) Moving-coil D.C. ammeter, accurate up to 60 amps.
- (b) Moving-coil D.C. voltmeter, scale 0-30 volts.
- (c) Ohmmeter—battery-powered. Do not use a hand-driven generator type for testing diodes.
- (d) Mains test lamp, 110-volt A.C., 15-watt.

Section N.12

DISMANTLING AND OVERHAULING THE 11AC ALTERNATOR

Removing

- (1) Disconnect the battery and detach the electrical leads from the alternator.
- (2) Slacken the alternator securing bolts, push the alternator towards the engine and detach the driving belt from the alternator pulley. Remove the securing bolts and detach the alternator from the engine.

Dismantling

- (3) Remove the securing nut and detach the drive pulley, fan, and key from the armature shaft.
- (4) Mark the relative positions of the drive end bracket, the stator lamination pack, and the slip-ring end bracket for correct reassembly.

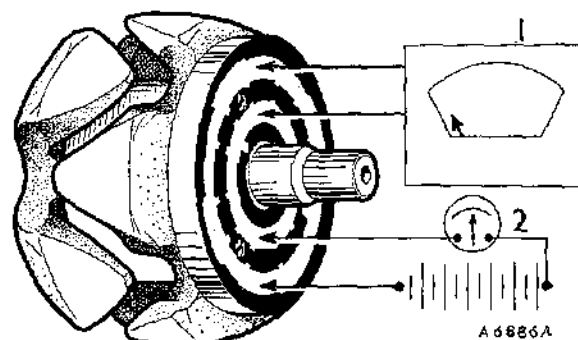
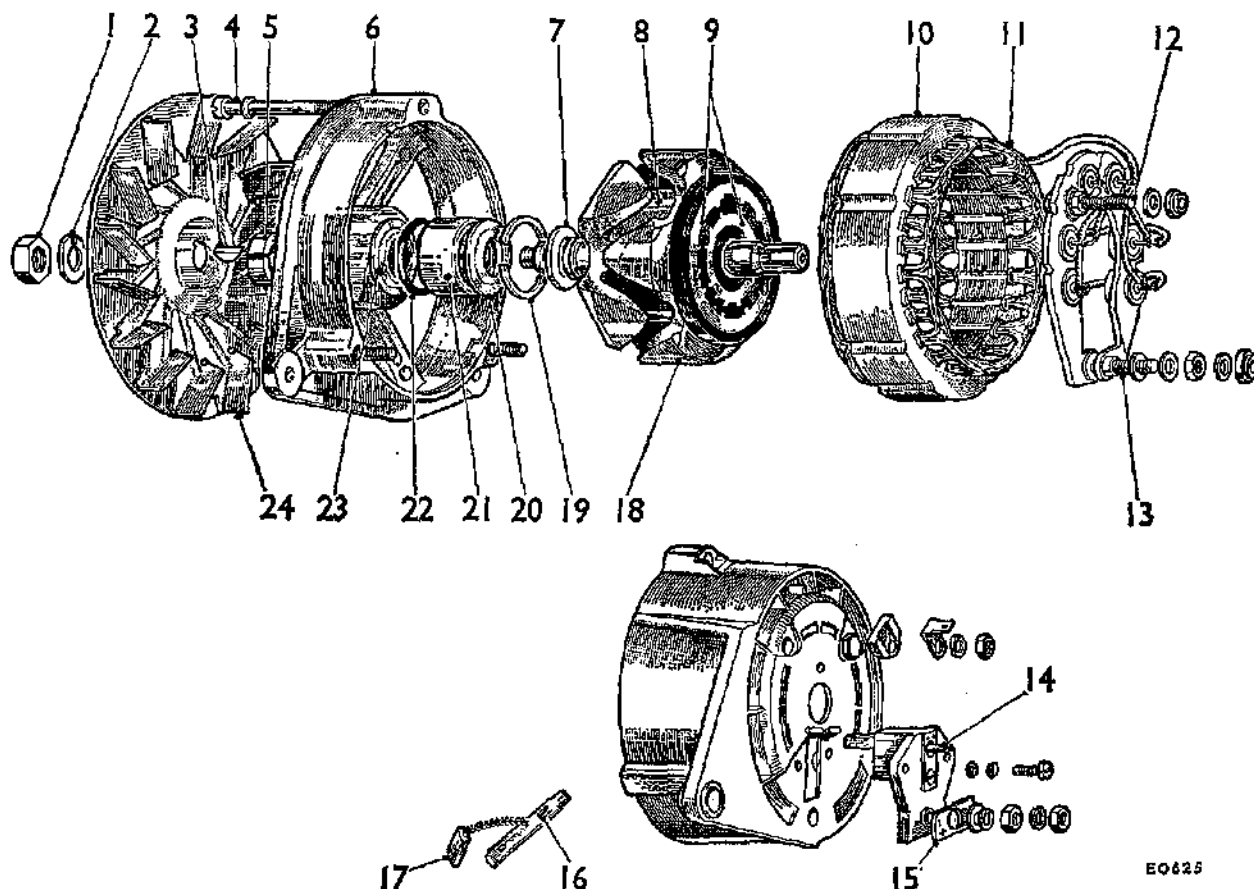

Fig. N.10

Using an ohmmeter (1) or a battery and ammeter (2) to test the resistance or current flow of the field winding



EO625

Fig. N.11

Alternator components

- | | | |
|---------------------------|--------------------------------------|--------------------------------|
| 1. Shaft nut. | 9. Slip rings. | 17. Brush. |
| 2. Spring washer. | 10. Stator laminations. | 18. Rotor. |
| 3. Key. | 11. Stator windings. | 19. Bearing circlip. |
| 4. Through-bolt. | 12. Warning light terminal. | 20. Bearing retaining plate. |
| 5. Distance collar. | 13. Output terminal. | 21. Ball bearing. |
| 6. Drive end bracket. | 14. Field terminal blade. | 22. 'O' ring oil seal. |
| 7. Jump ring shroud. | 15. Output terminal plastic strip. | 23. 'O' ring retaining washer. |
| 8. Rotor (field) winding. | 16. Terminal blade retaining tongue. | 24. Fan. |

Rotor

- (a) Test the rotor windings by connecting an ohmmeter, or a 12-volt battery supply and ammeter in series, between the slip-rings (Fig. N.10). The resistance or current of the field coils should be as given in 'GENERAL DATA'.
- (b) Defective insulation between the slip-rings and one of the rotor poles. Use a mains test lamp (110-volt A.C., 15-watt), connect it between one of the slip-rings and rotor poles; if the lamp lights, the coil is earthing. Replace the rotor assembly.

NOTE.—Do not attempt to machine the rotor poles or true a distorted shaft.

Stator

- (a) Check for continuity of the stator windings. Unsolder the three stator cables from the heat sink assembly (see 'Replacing diode heat sink'). Connect any two of the three stator cables in

series with a 1.5-watt test lamp and a 12-volt battery. Repeat the test, replacing one of the two cables by the third. Failure of the test lamp to light in either test indicates that the stator windings are open circuit. Replace the stator.

- (b) Test insulation between stator coils and lamination pack with the mains test lamp. Connect the test probes between any of the three cable ends and the lamination pack. If the lamp lights, the stator coils are earthing. Replace the stator.

Carry out the following test before resoldering the stator cables.

Diodes

Test each diode by connecting a 12-volt D.C. supply and a 1.5-watt test lamp in series with each diode in turn as shown in Fig. N.12, and then reversing the connections. Current should flow in one direction only.

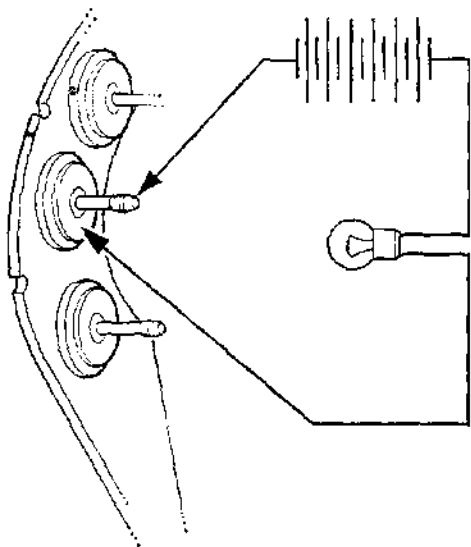

Fig. N.12
Testing the diodes

D0389

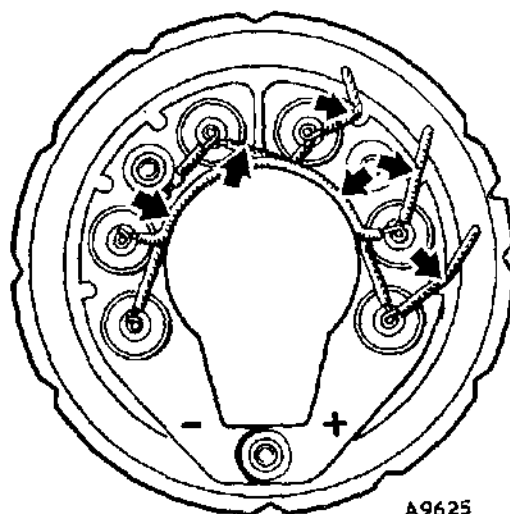

Fig. N.13
The heat sink diode internal connections

A9625

Should the bulb light up, or not light at all, in both tests the diode is defective. Replace the appropriate heat sink assembly.

The above procedure is adequate for testing. If, however, a battery-ohmmeter is used, it should be understood that no realistic readings can be obtained. A good diode will yield 'Infinity' in one direction, and a much lower, indefinite reading in the other.

Replacing diode heat sink

The heat sink assembly comprises two mutually insulated portions, one of positive polarity carries cathode-based diodes (marked red), and the other, negative, carries anode-base diodes (marked black).

- (a) Make the interconnections with 'M' grade 45-55 tin-lead solder.
- (b) Take great care to avoid overheating the diodes. Lightly grip the diode pins with a pair of long-nosed pliers, which will act as a thermal shunt, and carry out the soldering as quickly as possible.
- (c) Arrange the connections neatly around the heat sinks to ensure adequate clearance for the rotor, and secure with a suitable heat-resistant adhesive (Fig. N.13). The three stator connections must pass through the appropriate notches at the edge of the heat sink.

Bearings

Renew bearings which allow excessive side play of the rotor shaft.

Bearing—slip-ring end-cover

The needle-roller bearing and slip-ring end cover should be renewed as an assembly; if however a new bearing is to be fitted, follow the procedure below.

- (a) Check the depth to which the original bearing is pressed into its housing so that the new bearing may be positioned likewise.
- (b) Support the bearing boss, and press the bearing to the required depth. Pack with high-melting-point grease.

Bearing—drive-end bracket

- (a) Withdraw the rotor shaft from the drive-end bracket.
- (b) The bearing retaining plate is secured by either screws, rivets or a circlip.
File away the rivet heads and punch out the rivets; withdraw the screws or extract the circlip.
- (c) Press the bearing from the bracket.
- (d) Ensure that the new bearing is clean and pack it with high-melting-point grease. Locate the bearing and press fully into the housing.
- (e) Refit the bearing retaining plate. When circlip retained, press in enough to allow the circlip to be located.

Re-assembling

- (8) Reverse the dismantling procedure, bending the retaining tongues of the field terminal blades out at an angle of 30 degrees before fitting.
- (9) Align the marks on the drive-end bracket, stator lamination pack and the slip-ring end-bracket.
- (10) Support the inner journal of the drive-end bearing on a suitable tube and press the rotor home. Do not use the drive-end bracket as a support for the bearing while fitting the rotor. Tighten the through-bolts, brushbox fixing screws, and diode heat sink fixings to the correct torque figures (see 'GENERAL DATA').

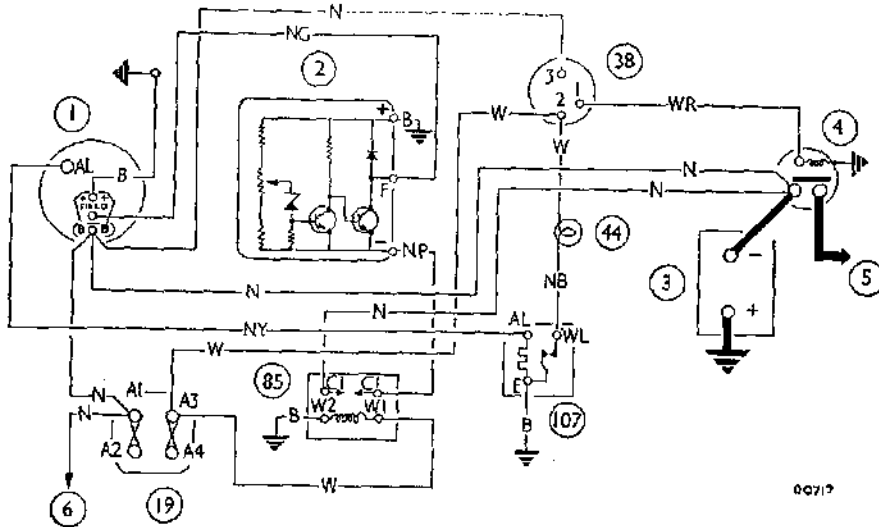

Fig. N.14

The alternator charging circuit

1. Alternator.
2. 4TR control unit.
3. 12-volt battery.
4. Starter solenoid.
5. Starter motor.
6. Lighting switch.
19. Fuse unit; 1-2, 35-amp.; 3-4, 35-amp.
38. Ignition/starter switch.
44. Ignition warning lamp.
85. Alternator field isolating relay.
107. Alternator charge indicator unit 3AW.

Section N.13

CONTROL UNIT (4TR)

Testing

- (1) Check the resistance of the wiring circuits of the alternator, control unit, and battery to control unit, including the relay unit. The resistance should not exceed .1 ohm.

NOTE.—Do not use an ohmmeter of the type which incorporates a hand-driven generator when checking the rectifiers or transistors.

- (2) Check that the battery is fully charged.
- (3) Check the voltage output as follows:
 - (a) Connect an accurate voltmeter across the battery terminals and note the reading.
 - (b) Connect an ammeter between the alternator main cable and its terminal 'B' on the alternator.
 - (c) Switch on enough lights to give a load of 2 amps.

- (d) Start the engine and run for at least eight minutes at an alternator speed of 3,000 r.p.m. until the ammeter reads 10 amps.
- (e) The voltmeter reading should then be between 13.9 and 14.3 volts. If the reading is unstable or has not risen above the battery voltage, renew the control unit. If the reading is stable but outside the correct limits, adjust the control unit.

- (4) If adjustment is needed, proceed as follows:
 - (a) Stop the engine, and detach the control unit from its mountings.
 - (b) Scrape out the compound sealing the potentiometer adjustment at the back of the unit.
 - (c) Ensure the connections on the unit are secure and re-start the engine.
 - (d) Run the engine to give an alternator speed of 3,000 r.p.m., with the conditions of test as in (3).

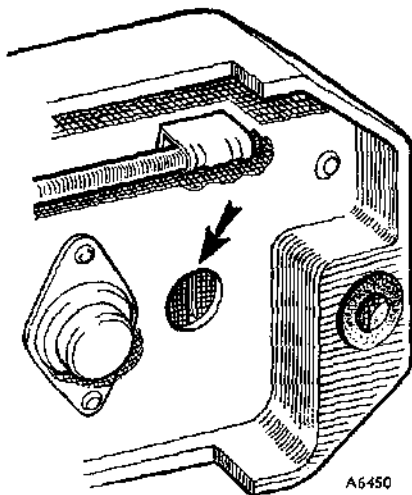

Fig. N.15

The 4TR control unit potentiometer adjuster. Turn clockwise to increase the voltage reading

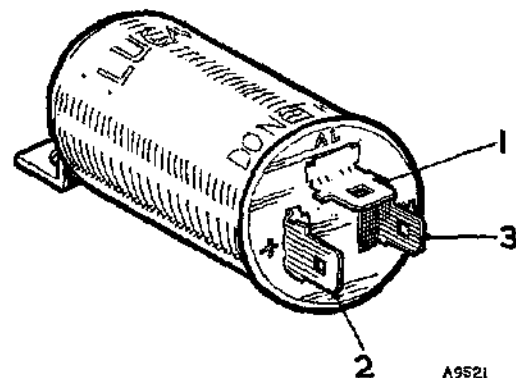

Fig. N.16

Warning light control terminals

1. Alternator 'AL'.
2. Positive '+'. 3. Warning light 'WL'.

- (e) Turn the adjuster slot gradually until the voltmeter registers a stable reading within the correct voltage limits (see Fig. N.15). Only a small adjuster movement is needed to effect an appreciable difference in the voltmeter reading.
- (f) Re-check by stopping the engine, re-starting it and running the alternator at 3,000 r.p.m. Check the voltmeter reading, and when it is correct, refit the control unit and remove the voltmeter and ammeter. Do not attempt to re-seal the adjuster hole. Application of undue heat will damage the control unit.

Section N.14

RELAY

Description

The relay de-energizes the alternator rotor field winding when the engine is stationary by disconnecting the supply from the rotor field immediately the ignition is switched 'off'. This allows contact 'C1' and 'C2' to part and open-circuit the rotor field winding. The alternator will not generate if the contacts fail to close when the ignition is switched 'on'.

Testing

- (1) Connect an ammeter as detailed in Section N.11, item (3).
- (2) Remove the lead from terminal 'C2' and temporarily join to the 'C1' terminal, ensuring good electrical contact.
- (3) If the alternator generates its specified output with the leads connected (as above), the relay is faulty and must be replaced.

Check continuity of relay operating winding, relay circuit wiring, and earth. If the relay and circuit are satisfactory (with cables 'C1' and 'C2' still joined), but no output from the alternator, check the alternator and control unit.

Section N.15

WARNING LIGHT CONTROL

The control is electrically connected to the centre point of one pair of diodes in the alternator and enables a warning light to be used to indicate that the alternator is charging when the engine is running at normal speed. If proved faulty, replace the unit.



SECTION Nb

THE ELECTRICAL SYSTEM

The information contained in this section refers specifically to new or modified components fitted to the Mini range coincident with the introduction of NEGATIVE earth electrical systems and must be used in conjunction with Section N.

| | <i>Section</i> |
|--|----------------|
| Alternator (type 16ACR) | Nb.9 |
| Direction indicator flasher unit | Nb.6 |
| Instrument panel (Clubman and 1275 GT) | Nb.1 |
| Instrument panel printed circuit (Clubman and 1275 GT) | Nb.3 |
| Instruments (Clubman and 1275 GT) | Nb.2 |
| Lamps, bulb replacement, etc.—Refer to Handbook | |
| Speedometer drive cable | Nb.5 |
| Starter (type M35J—inertia drive) | Nb.7 |
| Voltage stabilizer | Nb.4 |
| Windscreen wiper motor (type 14W) | Nb.8 |
| Wiring diagrams with master key | Appendix |

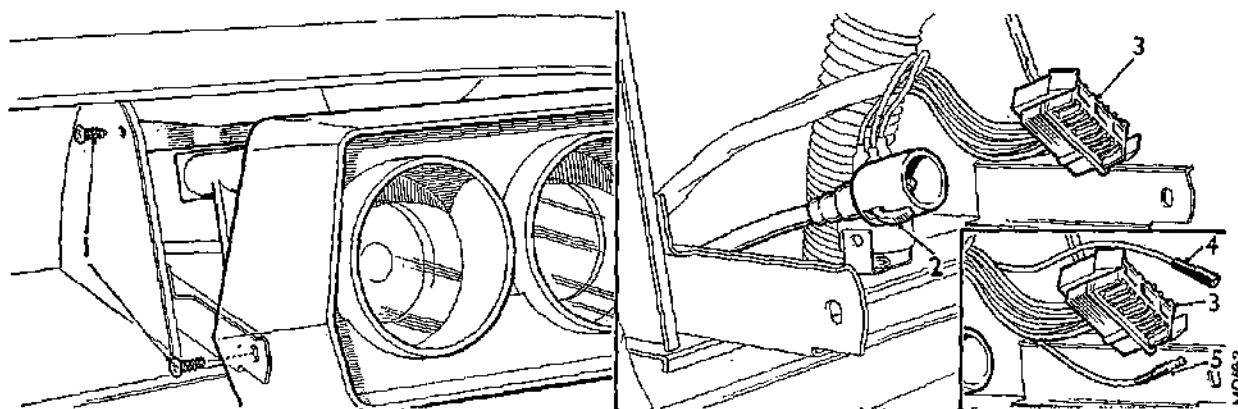

Fig. Nb.1

Removing the instrument panel (Mini Clubman and 1275 GT)

- | | |
|-------------------------------------|--------------------------|
| 1. Panel securing screws. | 4. Tachometer connection |
| 2. Speedometer cable release lever. | 5. Tachometer connection |
| 3. Multi-plug wiring connector. | |

Section Nb.1

INSTRUMENT PANEL (Clubman and 1275 GT)

Removing

- (1) Disconnect the battery earth cable (NEGATIVE).
- (2) Remove the air ventilation louvre adjacent to the instrument panel (see Section Rb.4).
- (3) Release the portion of the door seal securing the fascia trim liner, withdraw the liner from behind the side of the panel and remove it.
- (4) Release the trim liner on the other side of the instrument panel in a similar manner but do not remove it; the instrument panel securing screws are now accessible (see Fig. Nb.1).
- (5) Remove the four securing screws (1) and partially withdraw the panel; press in the release lever (2) on the speedometer cable and pull the cable out of the instrument. Pull out the multi-plug wiring connector (3) from the rear of the panel and remove the assembly (see Fig. Nb.1).

1275 GT. In addition to the above instructions also disconnect the tachometer connections (4) and (5) (see Fig. Nb.1).

Refitting

- (6) Reverse the removing instructions but note that the connector plug will fit one way only and make sure the speedometer cable is fully engaged in the instrument. Carefully refit the trim liners and use adhesive when refitting the door seal.

Section Nb.2

INSTRUMENTS (Clubman and 1275 GT)

Removing

- (1) Remove the instrument panel (see Section Nb.1)

Nb.2

Removal of the instruments for replacement is as follows:

Speedometer (Clubman)

- (2) Remove the screws securing the complete instrument unit to the panel, and lift off the unit.
- (3) Remove the three clips (1) and withdraw the lens assembly (2) (see Fig. Nb.2).
- (4) Unscrew the retaining screws (3) and withdraw the speedometer unit (4) (see Fig. Nb.2).

Speedometer (1275 GT)

- (5) Before removing the complete instrument unit as detailed in item (2), disconnect the printed circuit earth connection (arrowed) and remove the illuminating light bulb holder (5) from the tachometer (see Fig. Nb.2).
- (6) Carry out instructions (3) and (4).

Fuel and temperature gauges

- (7) Remove the clips (1), withdraw the lens assembly (6) from the instrument unit and lift out the instrument sub-dial (7). Unscrew the appropriate securing screws (8) and remove the instrument(s) (9), (10) for replacement (see Fig. Nb.2).

Tachometer (1275 GT)

- (8) Disconnect the printed circuit earth connection (arrowed) and withdraw the illuminating bulb holder (5). Remove the screws securing the tachometer unit to the panel and lift out the complete assembly.

The tachometer is replaceable as a complete unit (12) (see Fig. Nb.2). Do not remove the unit from its casing.

Refitting

Instruments and gauges

- (9) Reverse the removing procedure for all units.

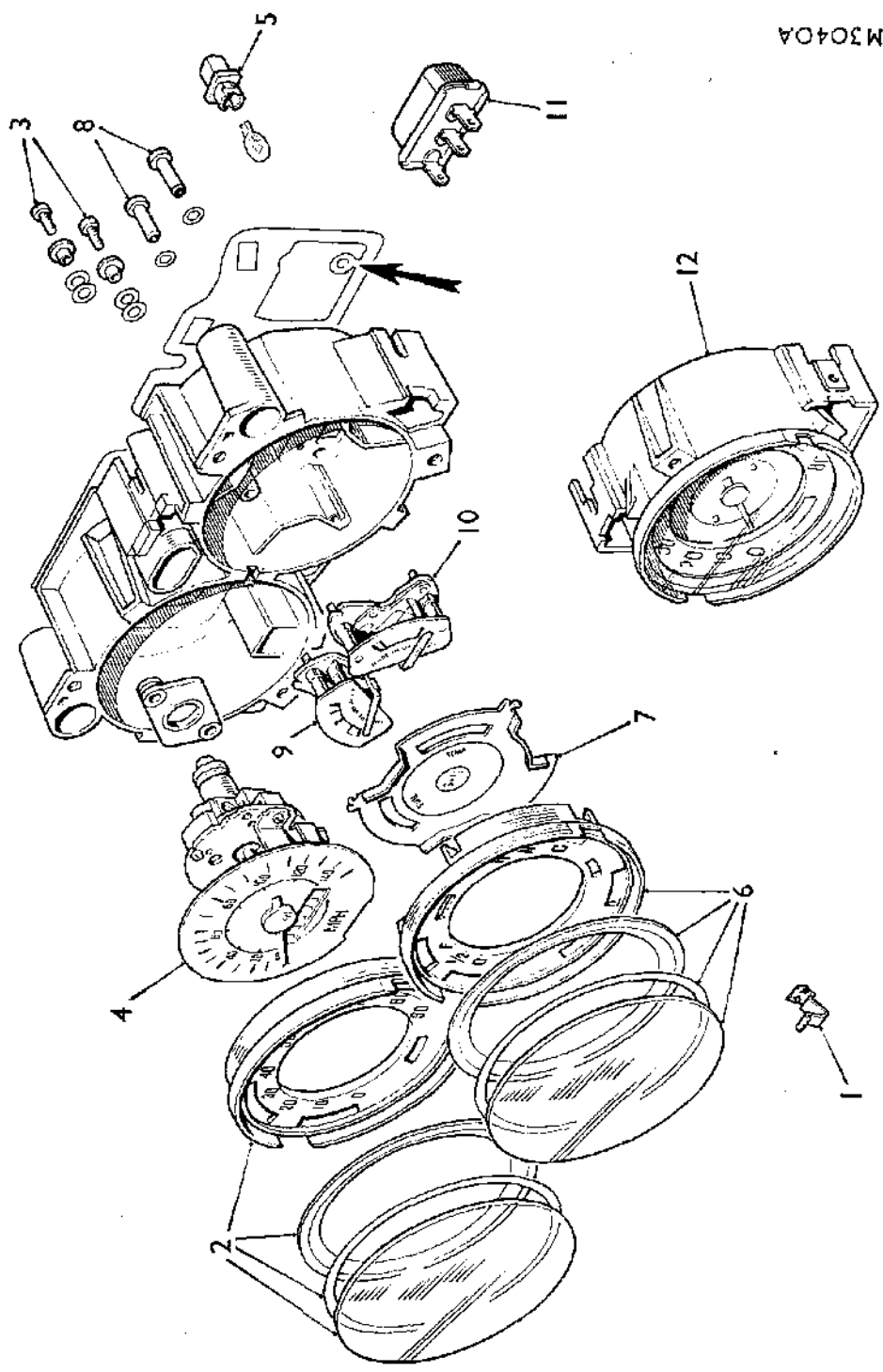

M3040A

Fig. Nb.2
 An exploded view of the instrument assembly (Mini Clubman and 1275 GT)

- 1. Instrument lens securing clips.
- 2. Speedometer dial and lens assembly.
- 3. Speedometer securing screws.
- 4. Speedometer unit.
- 5. Panel lamp bulb and holder.
- 6. Fuel/temperature gauge dial and lens assembly.
- 7. Fuel/temperature gauge sub-dial.
- 8. Fuel/temperature gauge securing screws.
- 9. Fuel gauge.
- 10. Temperature gauge.
- 11. Voltage stabilizer.
- 12. Tachometer assembly.

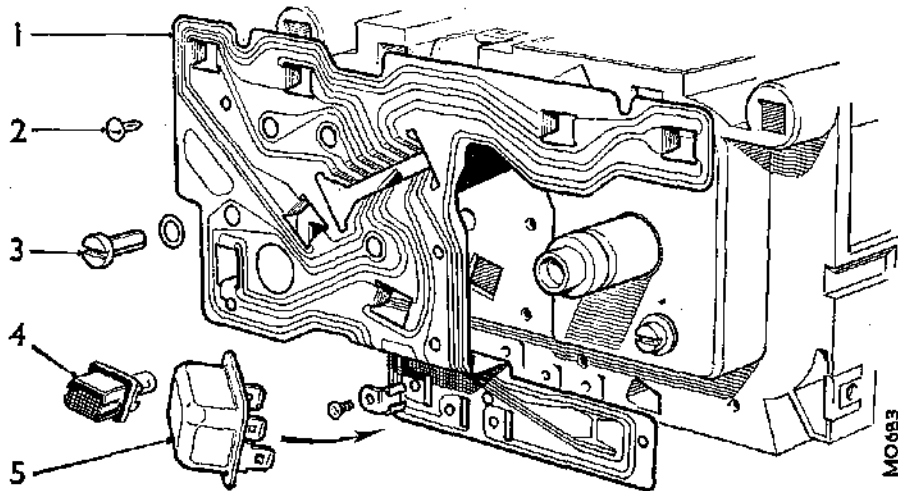

Fig. Nb.3

Removing the printed circuit

1. Printed circuit.
2. Printed circuit securing stud.
3. Fuel and temperature gauge securing screws.
4. Panel and warning lamp bulb holders.
5. Voltage stabilizer.

Section Nb.3

INSTRUMENT PANEL PRINTED CIRCUIT (Clubman and 1275 GT)

Removing

- (1) Remove the instrument panel (Section Nb.1).
- (2) Withdraw all the panel and warning light bulb holders (4) and pull off the voltage stabilizer (5) (see Fig. Nb.3).
- (3) Remove the three voltage stabilizer terminals.
- (4) To avoid damaging the fuel and temperature gauge indicators, remove these instruments from their holder as detailed in Section Nb.2.
- (5) 1275 GT. In addition to the above instructions disconnect the connections to the tachometer and withdraw the additional bulb holder(s).
- (6) Ease out the pins (2) securing the printed circuit and remove the circuit (1).

Replacing

- (7) Fit the replacement circuit, bending the bulb contacts into each respective holder recess. The remainder is a reversal of the removing procedure.

Section Nb.4

VOLTAGE STABILIZER

The voltage stabilizer is a push-fit into the rear of the instrument panel. For testing or replacement of the unit the panel must be withdrawn.

Testing

To carry out a rapid diagnosis of the voltage stabilizer, fuel and temperature gauges and their electrical circuits use a Smiths Automotive Instrument Tester (which incorporates a thermal-sensitive voltmeter).

- (1) Withdraw the instrument panel for access to the voltage stabilizer and gauges, (see Section Nb.1), but leave the battery connected and do not disturb the wiring connector plug on the rear of the panel.

Battery voltage

- (1) Connect a voltmeter to the '2' terminal of the fuse block and earth. With the ignition switched off, check the voltage, it should be approximately 12 volts.
- (2) Start the engine and run it at approximately 1,000 r.p.m., and ensure that the ignition warning light is out. Check the voltage, which should be 12 to 13 volts.

Wiring

- (3) Check for continuity between each unit and for short-circuits in the wiring to the temperature gauge transmitter.
- (4) Ensure that the voltage stabilizer, gauges and transmitter are earthed.

Voltage stabilizer

- (5) Switch the ignition on. After a pause of two minutes, check the main voltage between the output terminal '1' and earth; it should be 10 volts.
- (6) Substitute the voltage stabilizer if faulty.

Gauges

- (7) Check for continuity between the terminals with the wiring disconnected. **DO NOT short-circuit a gauge to earth.**
- (8) Substitute a gauge if faulty.

Transmitter

- (9) Check for continuity between the terminal and outer casing with the lead disconnected.
- (10) Substitute the transmitter if faulty.

Refitting

- (11) Refit the instrument panel as detailed in Section Nb.1.

Section Nb.5

SPEEDOMETER DRIVE CABLE

Removing

- (1) Remove the instrument panel (see Section Nb.1).
- (2) Press in the release lever (2) on the cable and pull the cable out of the instrument (see Fig. Nb.1). Withdraw the cable into the engine compartment.
- (3) From beneath the car, disconnect the cable through the aperture above the left-hand drive shaft. If the cable securing nut is too tight to turn by hand, use a suitable tool, or, remove the set screw securing the speedometer drive and withdraw the cable complete with the drive assembly and then remove the cable.

Refitting

- (4) Reverse the removing procedure, fitting a new joint washer if the speedometer drive has been removed. Tighten the lower securing nut by hand.

Lubrication

- (5) Withdraw the inner cable and lightly grease it except for 8 in. (200 mm.) at the speedometer end, re-insert it in the outer casing and wipe away surplus grease. Check that there is approximately $\frac{3}{8}$ in. (10 mm.) projection of the inner cable beyond the outer casing at the speedometer end.

Section Nb.6

DIRECTION INDICATOR FLASHER UNIT

Removing

- (1) Access to the unit is through an aperture in the fascia parcel shelf. Pull the flasher unit from its spring clip holder and through the access hole; pull off the wiring connections.

Replacing

- (2) Connect the wiring to the new unit and refit it into the holder.

Section Nb.7

**STARTER
(Type M35J—Inertia Drive)**

Removing

- (1) Disconnect the battery earth cable.
- (2) Disconnect the cable at the starter motor, remove the two bolts securing the starter motor to the flywheel housing and manoeuvre the starter away from the engine.

Dismantling

- (3) Remove the screws securing the drive-end bracket.
- (4) Withdraw the drive-end bracket complete with the armature and drive.

- (5) Remove the thrust washer from the commutator end of the armature.
- (6) Remove the screws securing the commutator end bracket.
- (7) Detach the bracket from the yoke, disengage the field brushes from the brush gear and remove the bracket.
- (8) If necessary the drive assembly can be removed by compressing the spring, removing the jump ring and withdrawing the drive from the shaft.

Inspecting and testing

Brush gear

- (9) Check the brush spring tension; fit a new brush into each holder in turn, and press on top of the brush with a push-type spring gauge until the brush protrudes approximately $\frac{1}{8}$ in. (1.5 mm.) from the holder. At this point check the gauge, which should read approximately 28 oz. (794 gm.); renew the commutator-end bracket if the tension is incorrect.
- (10) Check the brushes for wear, and renew any brush worn to or approaching the minimum length of $\frac{3}{8}$ in. (9.5 mm.).
- (11) To renew the end-bracket brushes, cut the brush leads from the terminal post, slot the head of the post sufficiently deep to accommodate the new brush leads and solder the new leads to the post.
- (12) To renew the field winding brushes, cut the brush leads approximately $\frac{1}{2}$ in. (6.4 mm.) from the field winding junction, solder the new brush leads to the stumps of the old ones ensuring that the insulation sleeves provide adequate coverage.

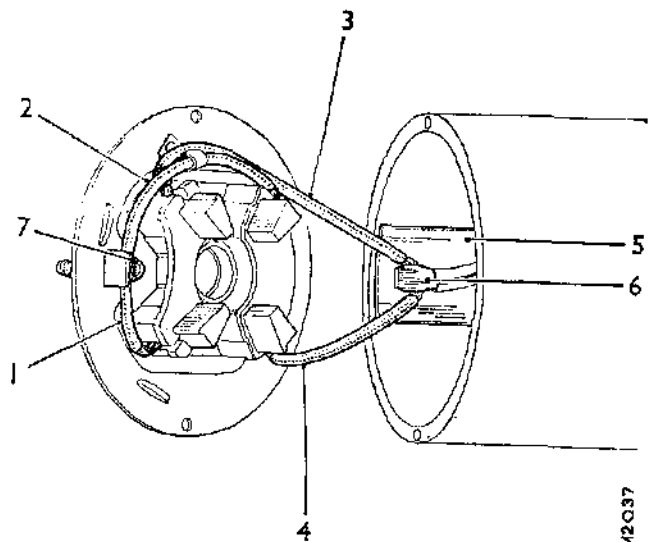

Fig. Nb.4

Commutator end bracket assembly

1. Short brush-flexible, commutator end bracket.
2. Long brush-flexible, commutator end bracket.
3. Long brush-flexible, field winding.
4. Short brush-flexible, field winding.
5. Yoke insulation piece.
6. Field winding junction.
7. Terminal post.

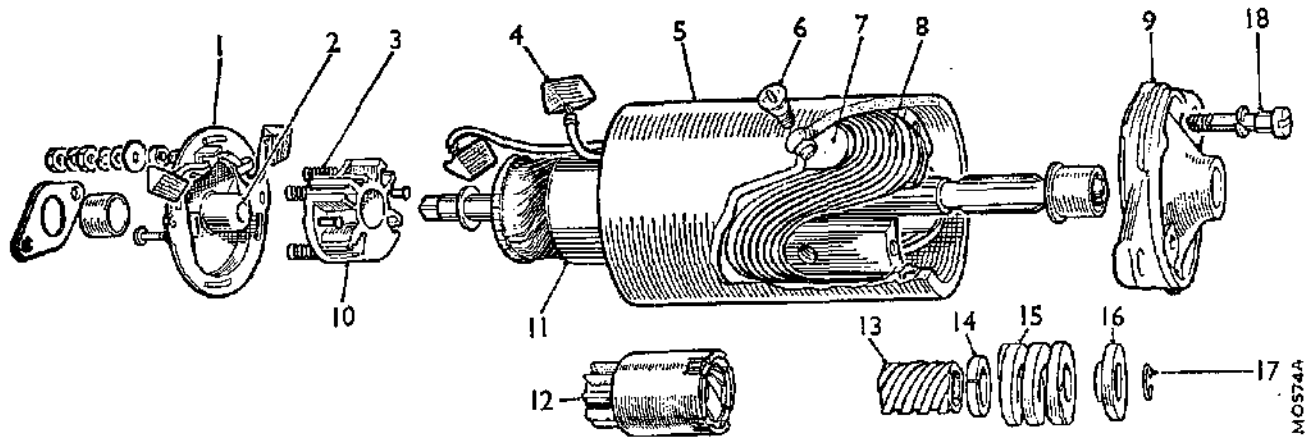

Fig. Nb.5

The M35J-type starter motor components

- | | | |
|----------------------------|--------------------------|-----------------------------|
| 1. Commutator end bracket. | 7. Pole shoe. | 13. Screwed sleeve. |
| 2. Bush housing. | 8. Field coils. | 14. Buffer washer. |
| 3. Brush springs. | 9. Drive end bracket. | 15. Main spring. |
| 4. Brushes. | 10. Brush box mouldings. | 16. Spring cup. |
| 5. Yoke. | 11. Armature. | 17. Circlip. |
| 6. Pole screw. | 12. Pinion and barrel. | 18. Drive end bracket bolt. |

Commutator

(13) Clean the commutator with a cloth moistened with fuel and examine it for burrs, pitting and excessive wear; provided that the amount of metal removed does not reduce the thickness of the commutator beyond the minimum thickness, the commutator may be reconditioned as follows:

- (a) Skim the commutator at high speed using a very sharp tool and removing the minimum amount of metal necessary to restore the surface.
- (b) Polish the commutator with very fine sandpaper.
- (c) Using an air blast, clean any copper residue from the armature.

IMPORTANT.—The commutator segment insulators must not be undercut.

Armature

- (14) Test the insulation of the armature windings with a 110-volt A.C., 15-watt test lamp connected between the armature shaft and the commutator; if the lamp lights the armature must be renewed.
- (15) Check the windings at their connections with the commutator for signs of melted solder or lifted conductors.
- (16) Check the shaft for distortion, and if it is bent or distorted the armature must be renewed; do not attempt to straighten the shaft or machine the armature core laminations.

Field windings

- (17) Connect a 12-volt battery-operated test lamp between each of the field brushes and a clean part

of the yoke; the lamp will light if continuity is satisfactory between the brushes, windings and yoke connection.

- (18) Disconnect the field windings from their riveted connection with the yoke, and using a 110-volt A.C., 15-watt test lamp connected between the yoke and each of the brushes in turn, check the insulation of the field windings; if the lamp lights the windings must be renewed.
- (19) The field windings may be renewed as follows:
 - (a) Disconnect the windings from their connection with the yoke.
 - (b) Slacken the four pole-shoe retaining screws using a wheel-operated screwdriver.
 - (c) Remove the retaining screws from one pair of diametrically opposite pole-shoes and remove them from the yoke.
 - (d) Slide the windings from beneath the remaining pair of pole-shoes and withdraw them from the yoke.
 - (e) Clean the inside of the yoke, the pole-shoes, and the insulation piece.
 - (f) Loosely fit the new windings and the pole-shoes and position the insulation piece between the yoke and the brush connections to the windings.
 - (g) Tighten the pole-shoe screws evenly using a wheel-operated screwdriver.
 - (h) Re-connect the winding junction connector to the yoke.

Commutator end bracket

- (20) Check the insulation of the springs and terminal post by connecting a 110-volt A.C., 15-watt test lamp between a clean part of the end bracket and, in turn, each spring and the terminal; the lamp will light if the insulation is unsatisfactory.

Bearings

- (21) If a bearing is worn sufficiently to allow excessive side play of the armature shaft, the bearing bush must be renewed as follows:

Commutator-end bracket

- (a) Drill out the rivets securing the brush box moulding and remove the moulding, bearing seal retaining plate and felt washer seal.
 (b) Screw a 1/2-in. tap a few turns into the bush and withdraw the bush with the tap.

Drive-end bracket

- (c) Support the bracket and press out the bush.

NOTE.—New bushes must be immersed in S.A.E. 30/40 engine oil for 24 hours or in oil heated to 100° C. (212° F.) for two hours prior to fitting. The bushes must not be reamed after fitting.

Commutator- and drive-end brackets

- (d) Using a polished, shouldered mandrel, the same diameter as the shaft bearing journal, press the new bushes into the brackets.

Drive

- (22) Wash the drive with paraffin (kerosene) and dry using an air blast.
 (23) Check the components for damage and excessive wear; renew worn or damaged parts.

Reassembling and refitting

- (24) Carry out items (3) to (8) in reverse order, and refit the starter by reversing the removal sequence items (1) and (2).

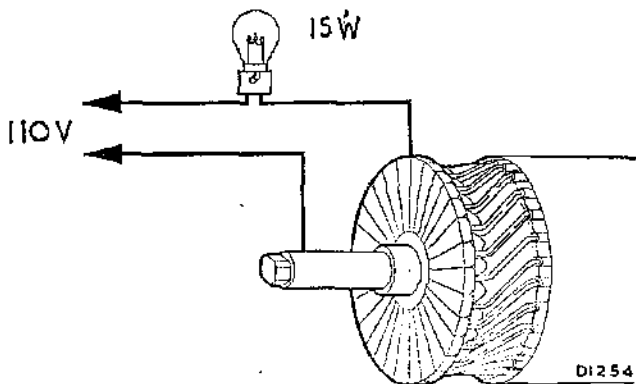

Fig. Nb.6

Armature insulation test

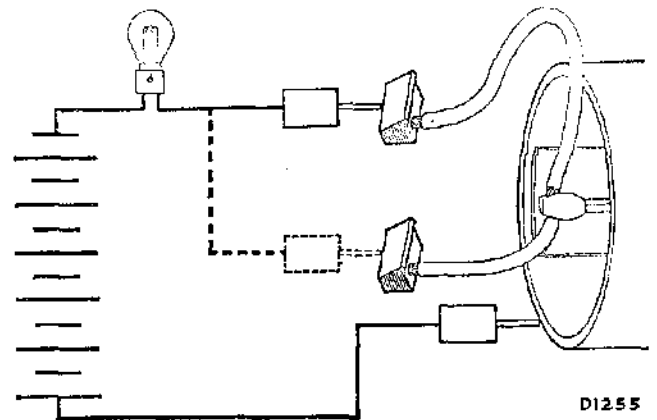

Fig. Nb.7

Field winding continuity test

Bench testing

Light running current

- (25) Clamp the starter firmly in a vice.
 (26) Connect a starter switch, a 0-600 amp. ammeter and a 12-volt battery in series, to the starter, using the lug as the earth connection.
 (27) Operate the switch and check the speed of the motor with a tachometer while noting the ammeter readings.
 (28) Check the readings obtained in item (27) against the figures given for light running speed and current in 'GENERAL DATA'.

Lock torque and current

- (29) With the starter connected and clamped as for the light running check, secure an arm to the driving pinion.
 (30) Connect a spring balance to the free end of the arm.
 (31) Operate the switch and note the ammeter and spring balance readings. Calculate the lock torque by multiplying the reading of the spring balance in pounds by the length of the arm in feet.
 (32) Check the readings obtained in item (31) against the figures given for lock torque and current in 'GENERAL DATA'.

Section Nb.8

WINDSCREEN WIPER

(Lucas Type 14W—Permanent Magnet)

Operation

This windscreen wiper, which is produced in either single- or two-speed form, has two permanent field magnets incorporated in a cylindrical yoke. The two-speed type is fitted with a third brush, to which the positive feed is transferred when a faster wiper speed is required.

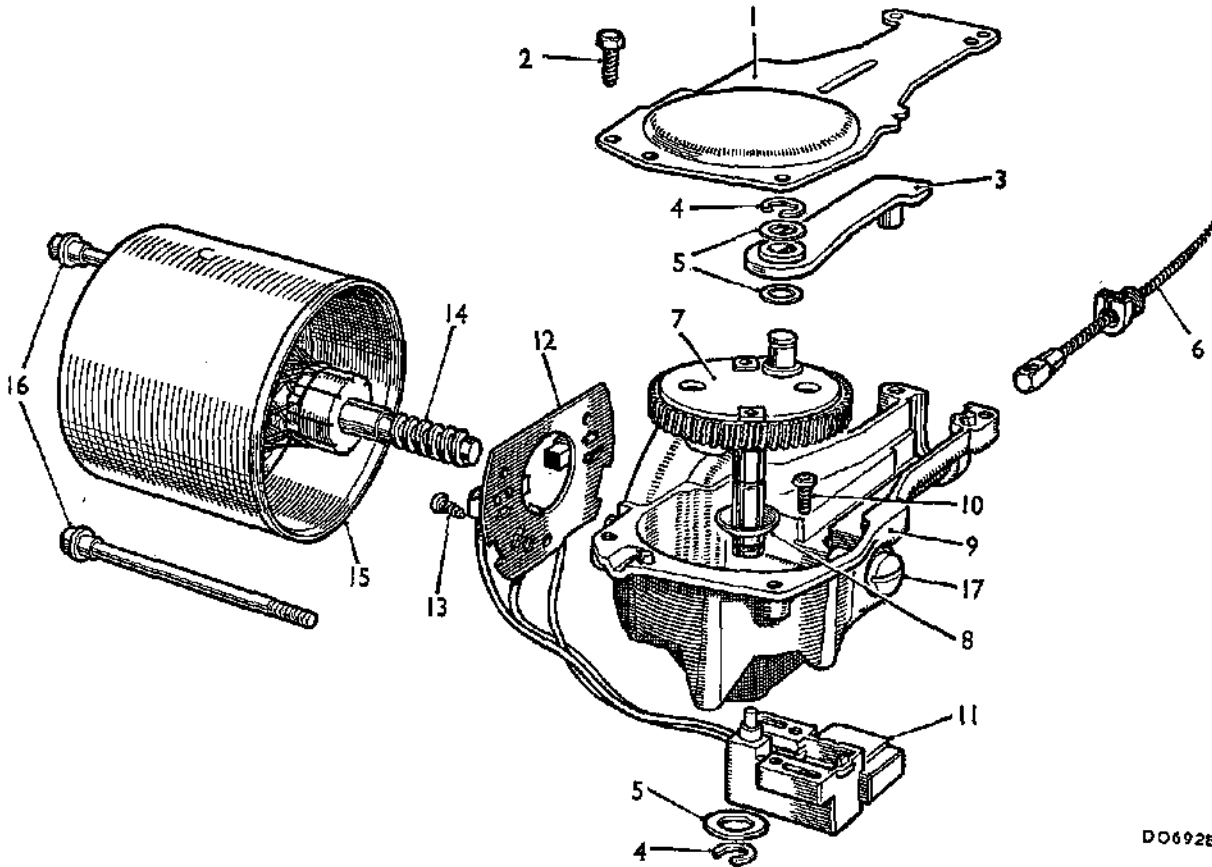

DO6928

Fig. Nb.8

The two-speed wiper motor components

- | | | |
|-------------------------|-----------------------------|----------------------------|
| 1. Gearbox cover. | 7. Shaft and gear. | 13. Screw for brush gear. |
| 2. Screw for cover. | 8. Dished washer. | 14. Armature. |
| 3. Connecting rod. | 9. Gearbox. | 15. Yoke assembly. |
| 4. Circlip. | 10. Screw for limit switch. | 16. Yoke bolts. |
| 5. Plain washers. | 11. Limit switch assembly. | 17. Armature thrust screw. |
| 6. Cross-head and rack. | 12. Brush gear. | |

A self-switching limit switch is incorporated in the terminal assembly. A cam on the under side of the gear wheel operates the two-stage switch via a plunger. When switched off, the motor continues under control of the limit switch until the wipers reach park position, the first stage contacts open and the motor is switched off. A period of no contact by the switch follows, then the second-stage contacts close to brake the armature and park the blades in the same position each time.

Testing

If the wiper fails to operate, or the wiper speed is slow or irregular, first locate the fault. Start by checking that the battery is fully charged, and that the wiper blades are in good condition and are not sticking.

- (1) Check the voltage at the motor connector plug; if the fuse (35/17 amp.) connecting '3' and '4' has blown, replace it, but before continuing make certain that this has not been caused by a fault in another circuit or by poor insulation.

- (2) Remove the motor, disconnect the cable rack at the gearbox (see 'Dismantling' items (13) to (15)) connect a 0-15 moving-coil ammeter to the supply cable, and switch on the wiper. If the current consumption of the motor and the operating speeds of the drive gear are not as given in 'GENERAL DATA', carry out the electrical tests; if the operation is now satisfactory, the fault is mechanical.

Electrical

- (3) If the wiper takes no current and the fuse is intact, check the electrical circuit for continuity, including the fascia switch. If the fuse had blown (item (1)) check the wiring insulation, and if in order carry out the electrical test (5).
- (4) If the wiper takes an abnormally low current, the motor must be dismantled and an examination made of the brush gear and commutator (see 'Inspecting').

- (5) If the wiper takes an abnormally high current, adjust the armature end-float if necessary (see item (25)). If the current consumption is still abnormal with the correct end-float, remove and test the armature (see 'Inspecting', item (22)).

NOTE.—If the motor is run other than from the vehicle's own connector, connect up as follows: negative—terminal 1, positive—terminal 5 for normal speed or terminal 3 for fast speed (two-speed type).

Mechanical

- (6) See that the wiper arm spindles rotate freely; replace seized or damaged wheelboxes.
- (7) Use a spring balance to measure the force required to pull the cable rack out of the casing from the fully-in position. This force must not exceed 6 lb. (2.7 kg.). Reform any bends of less than 9 in. (230 mm.) radius and replace any kinked or damaged tubes. Inspect the drive cable rack for damage.
- (8) Check the wheelboxes and connector tubes for alignment.

Removing

Motor and gearbox assembly

- (9) Disconnect the battery, withdraw the terminal connector from the motor, and release the earth wire from the valance.
- (10) Remove the wiper arms.
- (11) Unscrew the union on the Bundy tube at the gearbox and release the strap from the mounting bracket. Withdraw the assembly, pulling the cable rack from the Bundy tube.

Wheelboxes

- (12) Remove the wheelboxes, as described in Section N.9.

Dismantling

Motor and gearbox assembly (when removed)

- (13) Unscrew the four gearbox cover retaining screws and remove the cover.
- (14) Remove the circlip and flat washer securing the connecting rod to the crankpin.
- (15) Withdraw the connecting rod, noting the flat washer fitted under it.
- (16) Remove the circlip and washer securing the shaft and gear.
- (17) Clean any burrs from the gear shaft and withdraw the gear, noting the dished washer fitted under it.
- (18) After marking the motor yoke and gearbox to ensure that they are reassembled the original way round, unscrew the two fixing bolts and remove the yoke and armature assembly. Keep the yoke clear of metallic particles which will be attracted to the pole pieces.
- (19) Remove the screws securing the brush gear and the terminal and switch assembly, which are connected by cables, and remove both of them.

Inspecting

Motor and gearbox assembly

- (20) Examine the brush gear assembly, which must be replaced before either of the main brushes is worn to the minimum length of $\frac{3}{8}$ in. (5 mm.), or the narrow section of the third brush (two-speed models) is worn down to the full width of the brush (see Fig. Nb.9).
- (21) Check that the brushes move freely in the boxes and test the brush spring pressure with a push-type gauge. The gauge reading should be 5 to 7 oz. (140 to 200 gm.) when the bottom of the brush is level with the end of the slot in the brush box (see Fig. Nb.9). Renew the brush gear assembly if the springs are unsatisfactory.
- (22) Test the armature for open- or short-circuits. Use a mains test lamp of 110 volts and 15 watts and renew the armature if faulty.
- (23) Examine the gear wheel for damage or excessive wear. Renew if necessary.

Reassembling

Motor and gearbox assembly

- (24) Reverse the dismantling procedure in (13) to (19), noting the following points.
 - (a) If either the brush gear or switch assembly requires replacing, unsolder the motor supply leads at the brush boxes. If a new switch is to be fitted to a single-speed motor remove the third wire, yellow and green, at the switch terminal. Use high-melting-point solder to re-connect the leads to the brush boxes, in the order shown in Fig. Nb.9, when refitting the new assembly(ies); ensure that the leads are inside the recess in the switch unit moulding when refitting it to the gearbox.

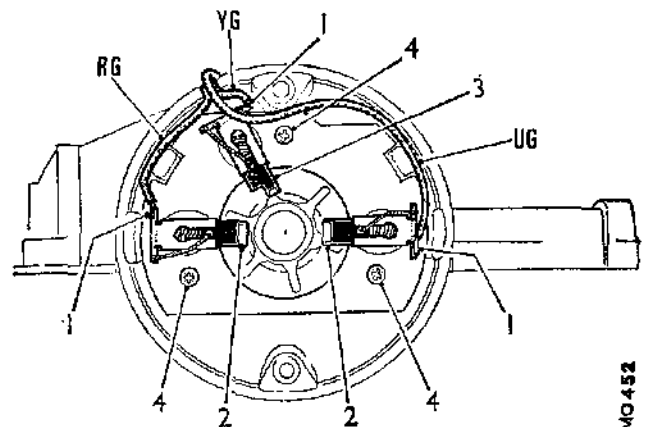

Fig. Nb.9

The brush gear assembly components

- | | |
|------------------------------------|---|
| 1. Soldered brush box connections. | 3. Fast-speed brush (where fitted). |
| 2. Main brushes. | 4. Brush gear assembly securing screws. |
| RG—Red with green. | YG—Yellow with green. |
| | UG—Blue with green. |

- (b) Use Ragosine Listate Grease to lubricate the gear wheel teeth and cam, armature shaft worm gear, connecting rod and connecting pin, crosshead slide, cable rack and wheelbox gear wheels.
- (c) Use Shell Turbo 41 oil to lubricate the bearing bushes, armature shaft bearing journals (sparingly), gear wheel shaft and crankpin, felt washer in the yoke bearing (thoroughly soak), and the wheelbox spindles.
- (d) If a replacement armature is being fitted, slacken the thrust screw to provide end float for fitting the yoke.
- (e) Tighten the yoke fixing bolts a to torque figure of 14 lb. in. (0.16 kg. m.).
- (f) Fit the dished washer beneath the gear wheel with its concave side towards the gear wheel.

IMPORTANT.—If a new gear wheel is being fitted, ensure that the type obtained has the correct relationship between the crankpin and ramp to give the parking position required for either right- or left-hand-drive vehicles (see Fig. Nb.10).

- (g) When fitting the connecting rod to the crankpin ensure that the larger of the two flat washers is fitted under the connecting rod with the smaller one on top beneath the circlip.

Armature end-float adjusting

- (25) Tighten the thrust screw until the end-float is just eliminated, and then turn back one-quarter turn to give an end-float within the limits of .002 to .008 in. (.05 to .2 mm.). Measure the gap under the head of the thrust screw with a feeler gauge, fit a suitable shim beneath it and fully tighten it.

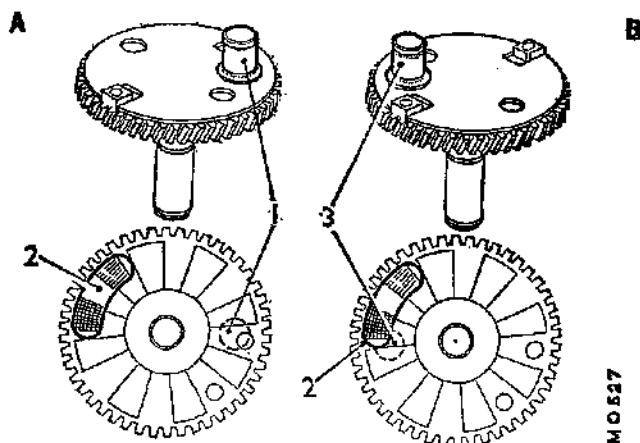

Fig. Nb.10

The gear wheel showing the alternative positions of the crankpin

- (A) R.H.D. cars: cable rack retracted with the crankpin (1) opposite the ramp (2).
- (B) L.H.D. cars: cable rack extended with the crankpin (3) adjacent to the ramp (2).

Nb.10

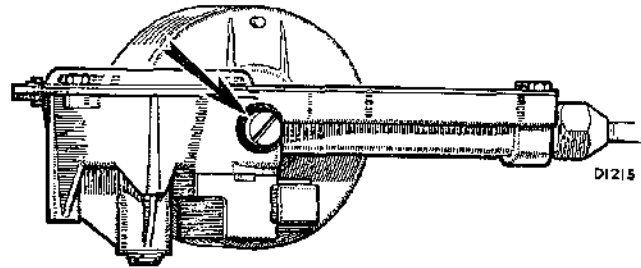

Fig. Nb.11

The armature end-float adjusting screw

Refitting

- (26) Reverse the procedure (9) to (12), leaving the wheelbox covers slack until after the cable rack has been inserted and the motor secured. Do not re-fit the wiper blades until after the action of the wheelboxes has been checked.

Section Nb.9

ALTERNATOR

(Lucas type 16ACR)

The model 16ACR alternator is similar in basic construction to that of the type 11AC as described in Section N.12, except that the slip-rings are mounted behind the rear rotor shaft bearing outside the slip-ring end bracket, and no separate control unit is fitted. Instead, a voltage regulator, of micro-circuit construction is incorporated on the slip-ring end bracket, inside the alternator cover.

Precautions

The alternator service precautions given in Section N.10 must be observed. Note that the battery polarity is **NEGATIVE EARTH**, which must be maintained at all times. The field connector block, which has three blades and is marked 'B+' and 'IND', has an offset moulded stop and must be removed before the main output connector block, which has two blades and is marked '+' and '-'. Since the B+ connector blade, although shrouded, is always live, disconnect the battery earth before removing the field connector block.

Testing in position

Output test

- (1) Check that the fan belt is correctly tensioned and that all charging circuit electrical connections are secure.
- (2) Run the engine at fast idle speed until its normal operating temperature is reached, and see that the battery is fully charged.
- (3) Disconnect both connector blocks from the alternator.

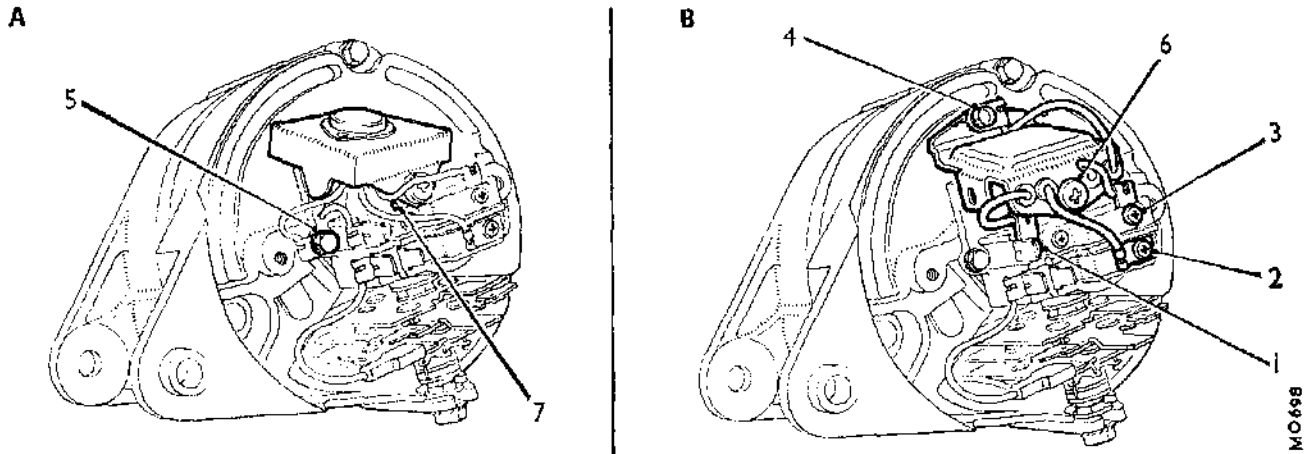

Fig. Nb.12

The in-built regulator connections, showing 'A' the 11TR and 'B' the 8TR type of regulator unit

- | | |
|---|------------------------|
| 1. B+. | 4. Earth (-)—8TR. |
| 2. Positive (+). | 5. Earth (-)—11TR. |
| 3. Field (F). | 6. Mounting screw—8TR. |
| 7. Long mounting screw and spacer—11TR. | |

- (4) Switch on the ignition and connect up a voltmeter with its negative lead to earth and with its positive lead to each cable connector blade of the two connector blocks in turn. If battery voltage is not available at any cable, locate and remedy the fault.
- (5) Remove the alternator end cover.
- (6) The leads from the in-built regulator to the alternator are unmarked. Refer to Fig. Nb.12 and then bridge the regulator field connector to a suitable earth, such as the earth-lead tag.
- (7) Refit the three-way connector block to the alternator. Do not refit the two-way connector block, instead, connect an ammeter in series with its positive blade and the main positive output terminal of the alternator. Do not make any connection to the inner (negative) main terminal.
- (8) Start the engine and run it at 2,800 r.p.m. The ammeter should read 34 amps. nominal. If the correct alternator output cannot be obtained, repair or replace the alternator.

Regulator test

- (9) Disconnect the lead which was connected up in item (6) to bridge the regulator field connector to earth.
- (10) Connect a voltmeter across the battery terminals. Start the engine and run it at 2,800 r.p.m. If the ammeter which was connected for item (7) of the output test reads zero, the regulator pack must be replaced.
- (11) Adjust the engine speed until the ammeter reading falls below 10 amps. The voltmeter should read between 14.0 and 14.4 volts. If it does not, either the regulator is faulty or there is a high resistance in the charging circuit cables; restore the original connections to the alternator and then check the charging circuit resistance.

Charging circuit resistance test

- (12) Connect a voltmeter between the positive terminal of the alternator and the positive terminal of the battery. Start the engine, switch on the headlamps, and run the engine at 2,800 r.p.m. The voltmeter reading should not exceed .5 volt.
- (13) Transfer the voltmeter connections to the negative terminals of the alternator and battery. With the engine running at 2,800 r.p.m. the voltmeter reading should not exceed .25 volt.
- (14) If either of the readings in (12) and (13) exceed the voltage stated, the charging circuit has developed a high-resistance fault, which must be traced and remedied.

If this test is satisfactory, then the incorrect voltage reading obtained in (11) would have been caused by a faulty regulator pack, so the alternator must either be replaced or removed for overhaul.

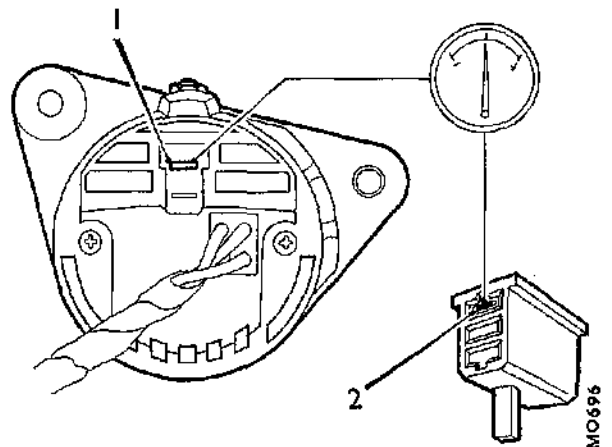

Fig. Nb.13

Alternator output test

1. Positive terminal of alternator.
2. Positive blade of two-way connector block.

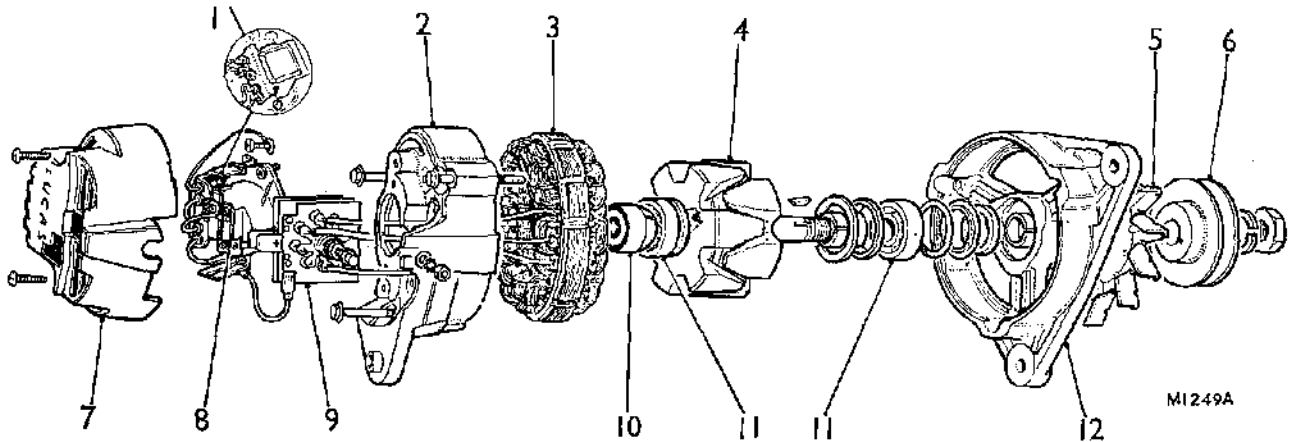

Fig. Nb.14

The 16ACR alternator components

- | | | |
|---------------------------|------------------------|------------------------|
| 1. Regulator pack. | 5. Fan. | 9. Rectifier pack. |
| 2. Slip-ring end bracket. | 6. Pulley. | 10. Slip-rings. |
| 3. Stator. | 7. End cover. | 11. Rotor bearings. |
| 4. Rotor. | 8. Brush box moulding. | 12. Drive end bracket. |

Removing the regulator pack

- (15) Remove the alternator as described in items (17) to (20).
- (16) Remove the moulded end cover, and identify the type of regulator pack fitted; the 8TR type has two short mounting screws at each end, while the 11TR type has a single longer one, with a spacer, screwed into the top lug of the brush box moulding only. Both types have two legs which locate in the brush box moulding.

Disconnect the coloured tag lead connectors from the brush box, and detach the black (earth) lead after removing the lower mounting screw (8TR) or one of the brush box retaining screws (11TR). Remove the remaining screw securing the regulator pack.

Removing the alternator

- (17) Withdraw the terminal block from the alternator.
- (18) Remove the adjusting link bolt from the alternator.
- (19) Slacken the alternator mounting bolts, lower the alternator and slip the fan belt from the alternator pulley.
- (20) Unscrew the alternator mounting bolts and remove the alternator.

Testing—alternator removed

- (21) Unscrew the cover retaining screws and remove the cover if this has not already been done in item (16).
- (22) Unsolder the three stator connections from the rectifier pack, noting the connection positions.

IMPORTANT.—When soldering or unsoldering connections to the diodes great care must be taken not to overheat the diodes or bend the pins. During the soldering operations the diode pins should be gripped lightly with a pair of long-nosed pliers which will then act as a thermal shunt, see Fig. Nb.15.

- (23) Unscrew the two brush moulding securing screws, and, if necessary, the lower regulator pack securing screw.

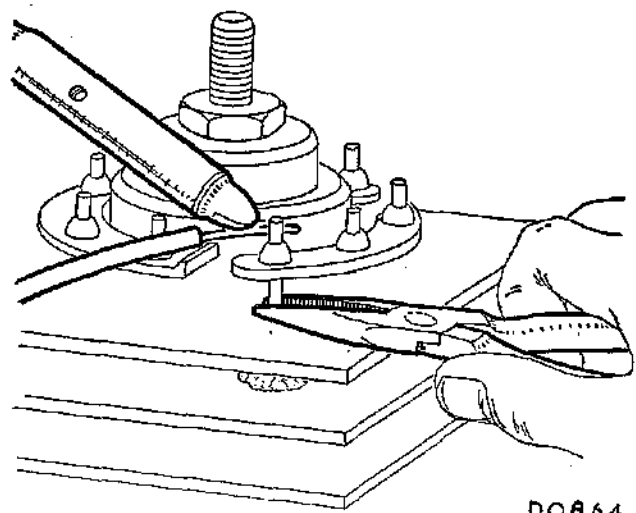

Fig. Nb.15

Using pliers as a thermal shunt when soldering the alternator diodes

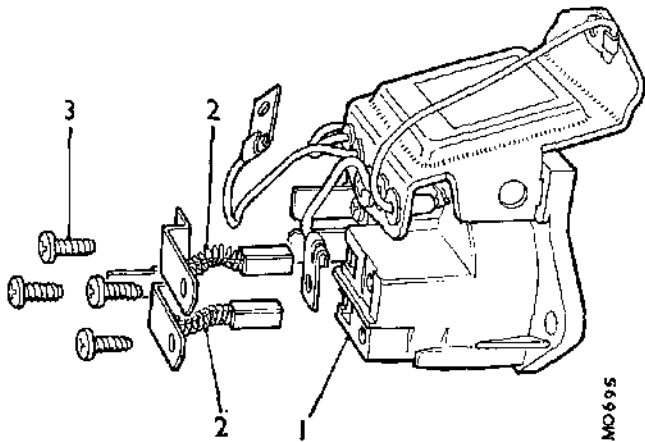

Fig. Nb.16

To renew a brush and spring assembly, remove the appropriate pair of screws and extract the brush assembly from its housing

- 1. Brush box moulding.
- 2. Brush and spring assembly.
- 3. Retaining screws (4).

- (24) Slacken the rectifier pack retaining nuts and withdraw both the brush moulding, with or without the regulator pack, and the rectifier pack.

Brushes

- (25) Check the brushes for wear by measuring the length of brush protruding beyond the brushbox moulding. If the length protruding is .2 in. (5 mm.) or less, the brush must be renewed.
- (26) Check that the brushes move freely in their holders. If a brush shows a tendency to stick, clean it with a petrol- (gasoline-)moistened cloth or, if necessary, polish the sides of the brush with a fine file.
- (27) Check the brush spring pressure using a push-type spring gauge. The gauge should register 7 to 10 oz. (198 to 283 gm.) when the brush is pushed back until its face is flush with the housing. If the gauge reading is outside the limits given, renew the brush assembly, as shown in Fig. Nb.16.

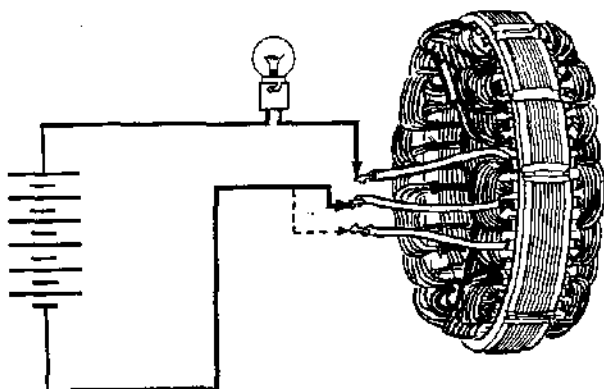

Fig. Nb.17

The stator winding continuity test

Slip-rings

- (28) Clean the surfaces of the slip-rings using a petrol- (gasoline-)moistened cloth.
- (29) Inspect the slip-ring surfaces for signs of burning; remove burn marks using very fine sand-paper. On no account must emery-cloth or similar abrasives be used or any attempt made to machine the slip-rings.

Rotor

- (30) Connect an ohmmeter, or a 12-volt battery and an ammeter, to the slip-rings. An ohmmeter reading of 4-3 ohms or an ammeter reading of 3 amps. should be recorded.
- (31) Using a 110-volt A.C. supply and a 15-watt test lamp, test for insulation between one of the slip-rings and one of the rotor poles. If the test lamp lights, the rotor must be renewed.

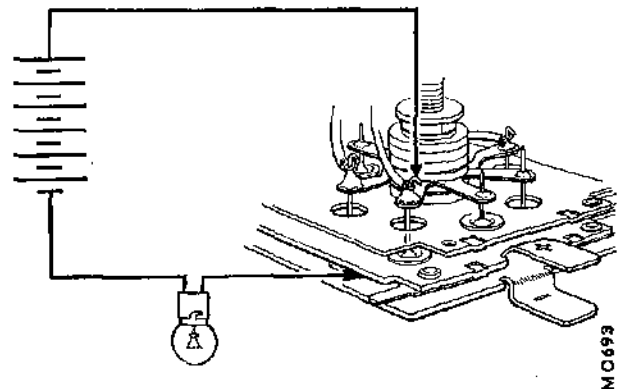

Fig. Nb.18

Testing the diodes

Stator

- (32) Connect a 12-volt battery and a 36-watt test lamp to two of the stator connections. Repeat the test, replacing one of the two stator connections with the third. If the test lamp fails to light in either of the tests, the stator must be renewed (see Fig. Nb.17).
- (33) Using a 110-volt A.C. supply and a 15-watt test lamp, test for insulation between any one of the three stator connections and the stator laminations. If the test lamp lights, the stator must be renewed.

Diodes

- (34) Connect a 12-volt battery and a 1.5-watt test lamp in turn to each of the nine diode pins and its corresponding heatsink on the rectifier pack, then reverse the connections. The lamp should light with the current flowing in one direction only. If the lamp lights in both directions or fails to light in either, the rectifier pack must be renewed (see Fig. Nb.18).

IMPORTANT.—See notes on soldering the diodes given in item (22).

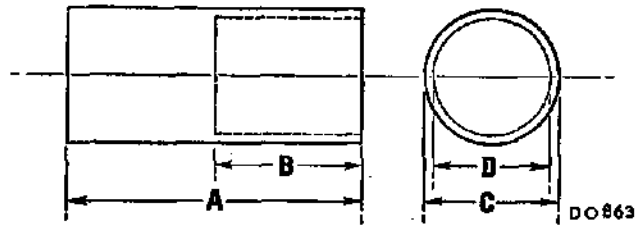

Fig. Nb.19

Dimensions of the rotor removing tool

- A. 3 in. (76 mm.)
- a. 1.5 in. (38 mm.)
- c. 1.32 in. (33.5 mm.)
- D. 1.24 in. (31.5 mm.)

Dismantling

- (35) Carry out the operations detailed in (21) to (24).
- (36) Remove the three through-bolts.
- (37) Fit a tube of the dimensions given in Fig. Nb.19 over the slip-ring moulding so that it registers against the outer track of the slip-ring end bearing and carefully drive the bearing from its housing.
- (38) Remove the shaft nut, washer, pulley, fan, and shaft key.
- (39) Press the rotor from the drive end bracket.
- (40) Remove the circlip retaining the drive end bearing and remove the bearing.
- (41) Unsolder the field connections from the slip-ring assembly and withdraw the assembly from the rotor shaft.
- (42) Remove the slip-ring end bearing.

Reassembling

- (43) Reverse the dismantling procedure in (35) to (42) and (21) to (24), noting the following points.
 - (a) Use Shell Alvania 'RA' to lubricate the bearings where necessary.
 - (b) When refitting the slip-ring end bearing, ensure that it is fitted with its open side facing towards the rotor and is pressed onto the rotor shaft as far as it will go.
 - (c) Re-solder the field connections to the slip-rings using Fry's H.T.3 solder.
 - (d) When refitting the rotor to the drive end bracket, support the inner track of the bearing with a suitable piece of tube. Do not use the drive end bracket as the only support for the bearing when fitting the rotor.
 - (e) Tighten the through-bolts evenly.
 - (f) Check that the brushes are entered in their housings before fitting the brush moulding.
 - (g) Tighten the shaft nut to the torque figure given in 'GENERAL DATA'.
 - (h) Refit the regulator pack to the brush moulding if it had been removed separately. See that the correct number and size of securing screws are used for the type being refitted, which need not be the same as the original, using the spacer if required. Refer to item (16).

Refitting the alternator

Reverse the removal procedure in (17) to (21), and ensure that the drive belt is correctly tensioned.

FAULT DIAGNOSIS

| Alternator | | | Probable fault and associated damage |
|-------------|-----------|--|--|
| Temperature | Noise | Output | |
| High | Normal | Higher than normal—40 amps. approximately at 2,800 r.p.m. | Live side output diode open-circuit. (May damage rotor windings and regulator output stage, overheat brush boxes, and blow warning light). |
| High | Excessive | Very low—10 amps. approximately at 2,800 r.p.m. | Live side output diode short-circuit. (May cause failure of associated field diode.) |
| Normal | Excessive | Poor at low speed, slightly below normal at 2,800 r.p.m.—32 amps. approximately. | Earth side output diode open-circuit. |
| Normal | Excessive | Very low at all speeds above 850 r.p.m.—7 amps. approximately. | Earth side output diode short-circuit or one phase winding shorted to earth. |
| Normal | Normal | Lower than normal—29 amps. approximately at 2,800 r.p.m. | Field diode open-circuit. |
| Normal | Excessive | Very low—7 amps. approximately at 2,800 r.p.m. | Field diode short-circuit. |

**THE ELECTRICAL SYSTEM
WIRING DIAGRAMS**

| | |
|---|-------------|
| | <i>Page</i> |
| Master key to wiring diagrams | Nb.ii |
| Wiring diagrams: | |
| Mini 850 De-Luxe Saloon, Van and Pick-up | Nb.iii |
| Mini 1000 Special De-luxe Saloon and Cooper 'S' Mk. III | Nb.iv |
| Mini Clubman Saloon and Estate | Nb.v |
| Mini 1275 GT | Nb.vi |

MASTER KEY TO WIRING DIAGRAMS

Some of the components listed in this key may not be fitted to individual models

| <i>No.</i> | <i>Description</i> | <i>No.</i> | <i>Description</i> |
|------------|--|------------|---|
| 1. | Dynamo. | 36. | Windscreen wiper switch. |
| 2. | Control box. | 37. | Windscreen wiper motor. |
| 3. | Battery (12-volt). | 38. | Ignition/starter switch. |
| 4. | Starter solenoid. | 39. | Ignition coil. |
| 5. | Starter motor. | 40. | Distributor. |
| 6. | Lighting switch. | 41. | Fuel pump. |
| 7. | Headlamp dip switch. | 42. | Oil pressure switch (when fitted). |
| 8. | R.H. headlamp. | 43. | Oil pressure gauge or warning lamp. |
| 9. | L.H. headlamp. | 44. | Ignition warning lamp. |
| 10. | Main-beam warning lamp. | 45. | Speedometer. |
| 11. | R.H. sidelamp. | 46. | Water temperature gauge. |
| 12. | L.H. sidelamp. | 47. | Water temperature transmitter. |
| 14. | Panel lamps. | 49. | Reverse lamp switch.† |
| 15. | Number-plate lamp(s). | 50. | Reverse lamp.† |
| 16. | R.H. stop and tail lamp. | 64. | Bi-metal instrument voltage stabilizer. |
| 17. | L.H. stop and tail lamp. | 67. | Line fuse (35 amp.). |
| 18. | Stop lamp switch. | 75. | Automatic transmission safety switch (when fitted). |
| 19. | Fuse block. | 83. | Induction heater and thermostat.† |
| 20. | Interior light. | 84. | Suction chamber heater.† |
| 21. | R.H. door switch(es). | 95. | Tachometer. |
| 22. | L.H. door switch(es). | 110. | R.H. repeater flasher. } when fitted. |
| 23. | Horn(s). | 111. | L.H. repeater flasher } when fitted. |
| 24. | Horn-push. | 115. | Rear window demister switch.* |
| 25. | Flasher unit. | 116. | Rear window demister unit.* |
| 26. | Direction indicator, headlamp flasher, and dip switch. | 139. | Alternative connections for two-speed wiper motor and switch. |
| 27. | Direction indicator warning lamp(s). | 150. | Rear window demist warning lamp.* |
| 28. | R.H. front flasher lamp. | 153. | Hazard warning switch. |
| 29. | L.H. front flasher lamp. | 154. | Hazard warning flasher unit } when fitted |
| 30. | R.H. rear flasher lamp. | 158. | Printed circuit instrument panel. |
| 31. | L.H. rear flasher lamp. | 159. | Brake pressure warning lamp and lamp push. } when fitted. |
| 32. | Heater or fresh-air blower switch.† | 160. | Brake pressure failure switch. } when fitted. |
| 33. | Heater or fresh-air blower.† | | |
| 34. | Fuel gauge. | | |
| 35. | Fuel gauge tank unit. | | |

* Optional extra.

† Optional extra/standard some models.

CABLE COLOUR CODE

| | | |
|-----------|-------------------|------------|
| N. Brown. | P. Purple. | W. White. |
| U. Blue. | G. Green. | Y. Yellow. |
| R. Red. | L.G. Light Green. | B. Black. |

When a cable has two colour code letters the first denotes the main colour and the second denotes the tracer colour.

Mini 850 De-Luxe Saloon, Van, and Pick-up

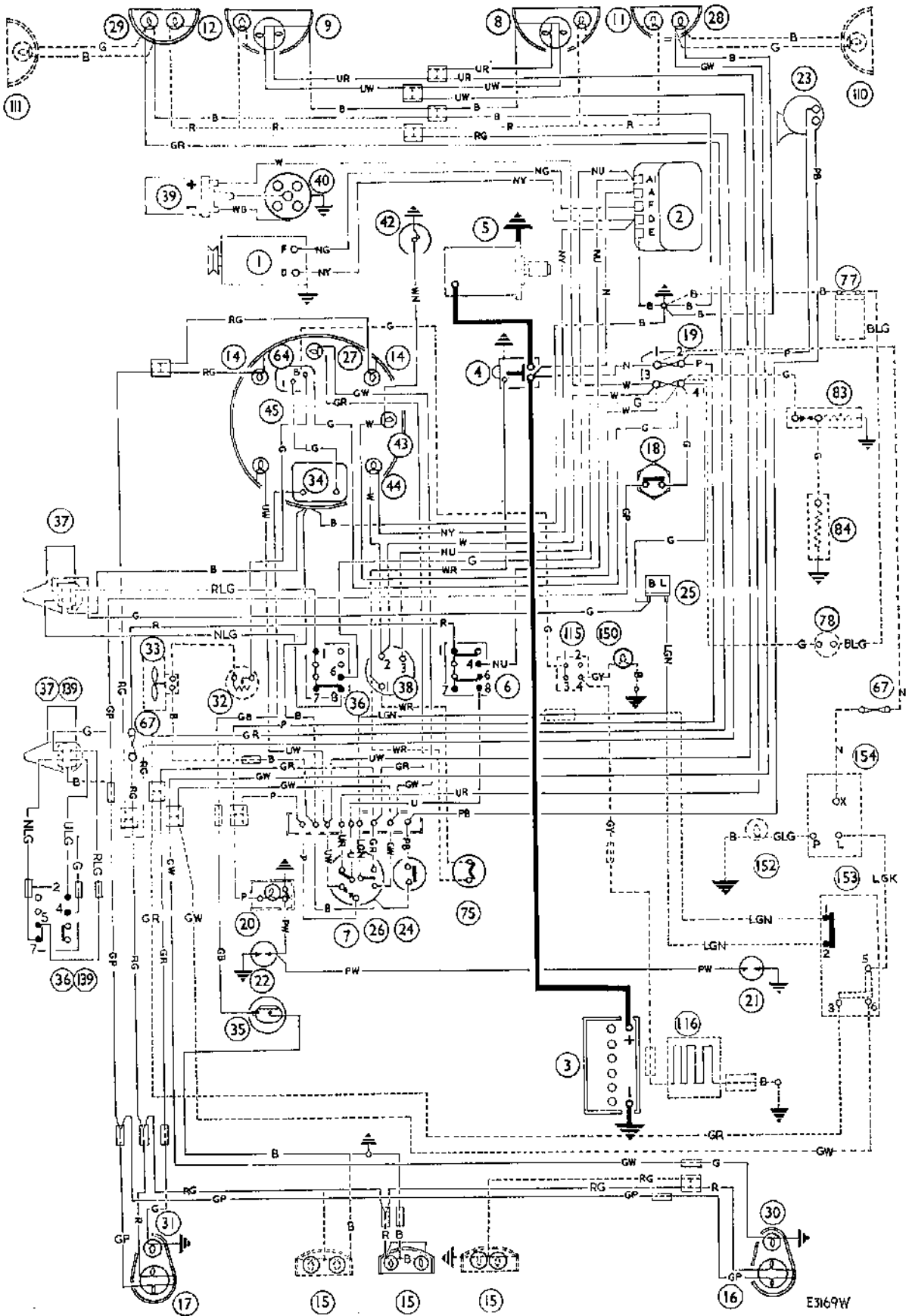

Mini 1000 Special De-luxe Saloon and Cooper 'S' Mk. III

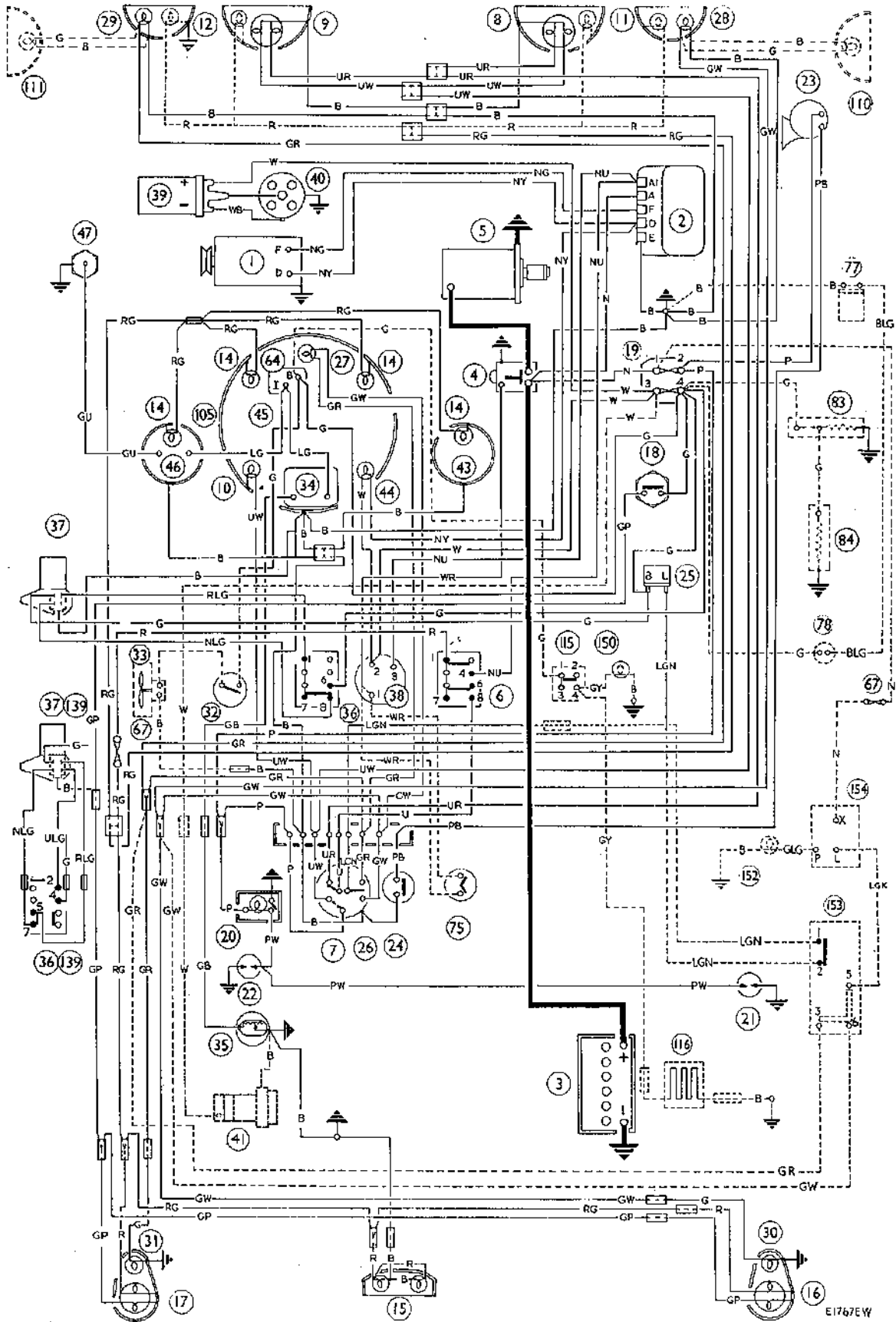

Mini Clubman Saloon and Estate

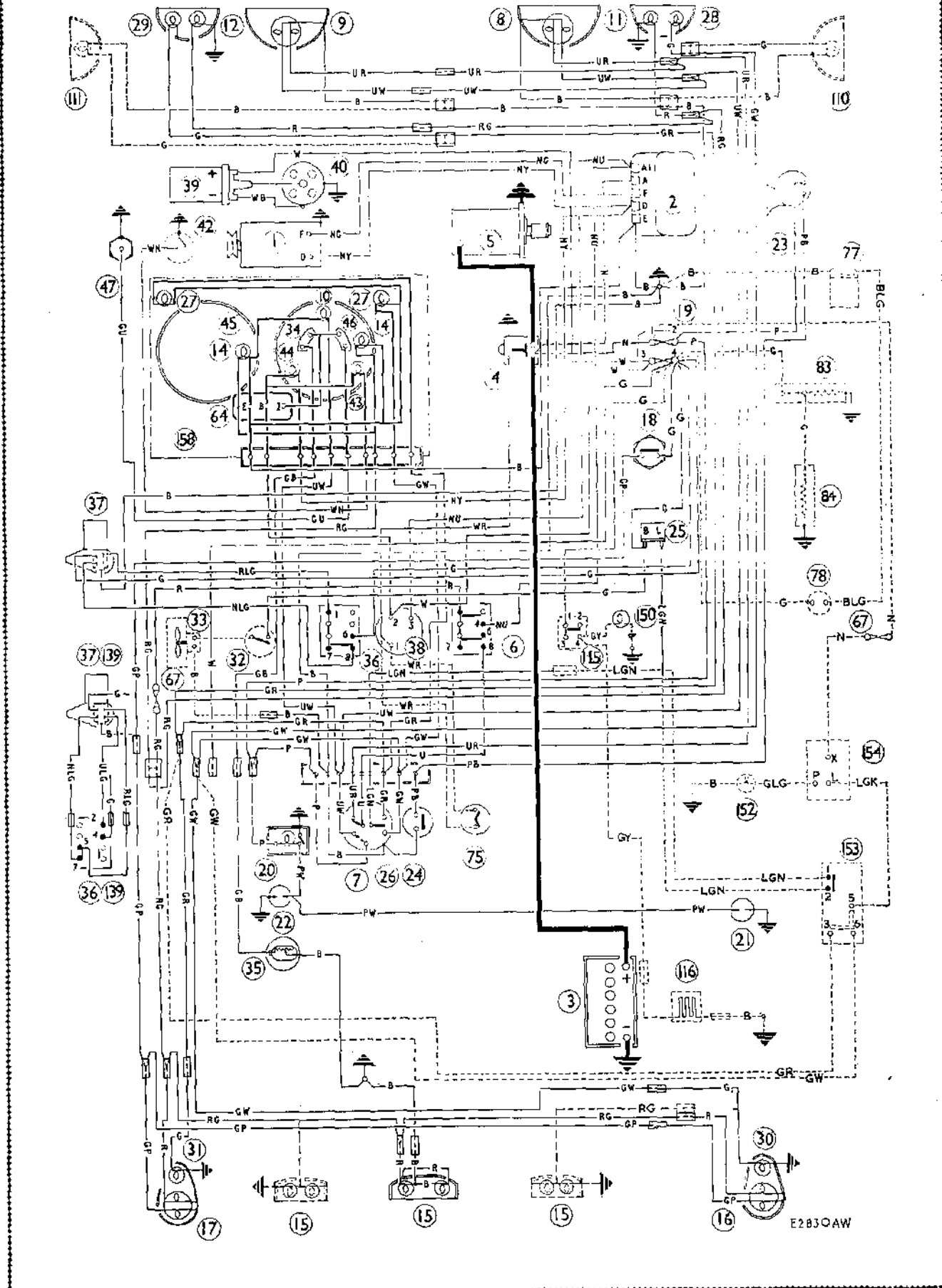

Mini 1275 GT

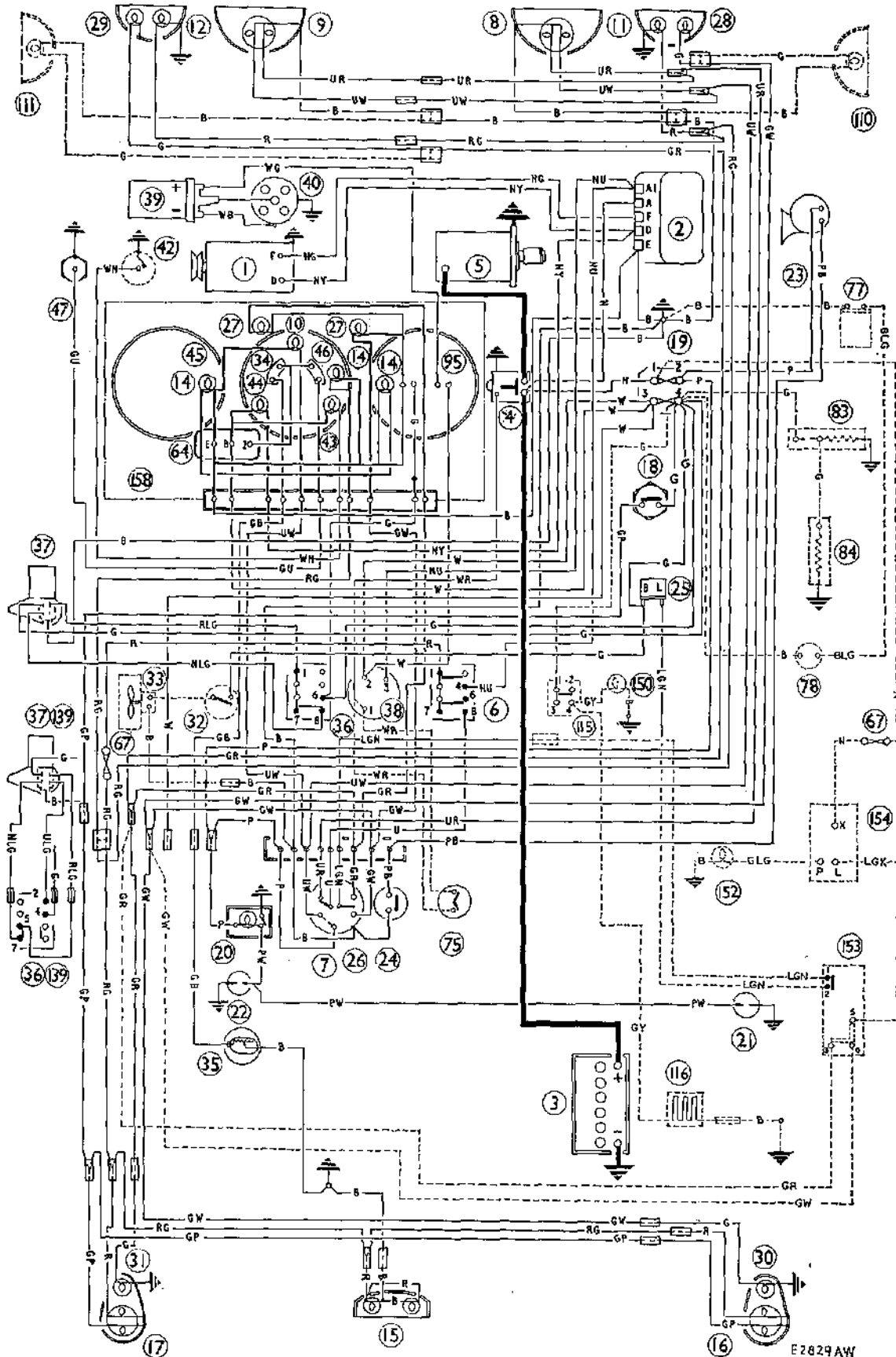

SECTION R

THE BODY

| | <i>Section</i> |
|---|----------------|
| Alignment | R.13-R.14 |
| Door frame—rear (Countryman and Traveller) .. | R.8 |
| Door locks | R.7 |
| Glasses | |
| Back-light | R.2 |
| Door | R.3 |
| Quarter-light | R.4 |
| Sliding (Countryman and Traveller) .. | R.9 |
| Windscreen | R.1 |
| Heater assembly (recirculatory type) .. | R.5 |
| Heater assembly (fresh-air type) .. | R.16 |
| Instrument panel (Mk. I models) .. | R.11 |
| Instrument nacelle (Mk. II models) .. | R.18 |
| Instruments (Mk. II models) .. | R.17 |
| Roof liner | R.6 |
| Speedometer (Super De-luxe and Cooper) .. | R.12 |
| Tilt frame and cover (Pick-up) .. | R.10 |
| Windscreen (Moke) | R.15 |

Section R.1**WINDSCREEN GLASS****Removing**

- (1) Lift the wiper blades from the glass.
- (2) Prise up the end of the locking filler and pull it from the rubber channel.
- (3) Push the glass from inside the car and ease the rubber surround from the body.

Refitting

- (4) Fit the rubber surround to the body and lubricate with soap and water.
- (5) Fit the glass into the lower channel of the rubber and lift the lip of the surround with the short peg of Service tool 18G 468, starting at one corner and working round.
- (6) Thread the locking filler through the handle and eye of the tool, insert the tool into the filler strip channel and draw the tool along the channel, feeding the filler through the tool. When cutting the filler, allow a small overlap and then force the ends into position.

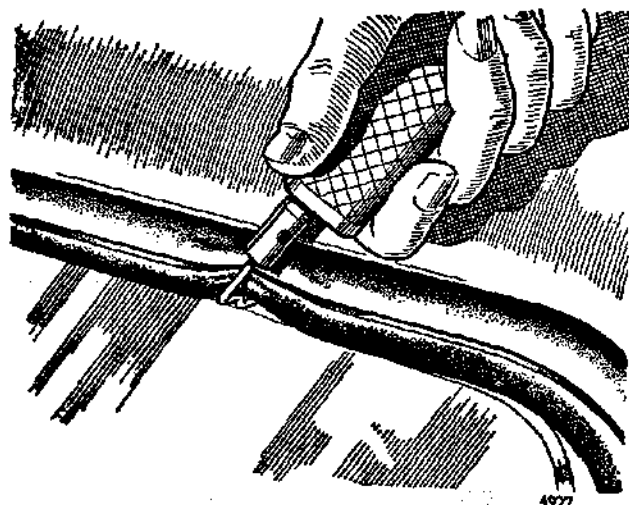
*Fig. R.1*

Use Service tool 18G 468 to ease the channel lip over the windscreen glass

- (4) Lubricate the body edge with soap and water, hold the glass in position, press lightly and pull the cord from inside the car to draw the lip of the rubber over the edge of the body.

Section R.2**BACK-LIGHT GLASS**

As items (2) to (6) in 'Windscreen Glass'.

Removing (Hinged type)

- (5) Remove the catch from the body.
- (6) Open the quarter-light, ease up the seal on the body, unscrew the exposed screws securing the hinge and detach the window assembly.
- (7) Remove the frame from the glass after unscrewing the hinge screws at top and bottom.

Refitting

Reverse the removal instructions.

Section R.3**DOOR GLASSES****Removing and refitting**

Take out the screws from the lower channel and remove the glass and channel. Reverse to refit.

Section R.5**HEATER ASSEMBLY
(Recirculatory Type)****Initial fitting**

Full instructions for fitting are contained in the heater kit.

Removing

- (1) Disconnect the battery.
- (2) Drain the cooling system.
- (3) Disconnect the motor leads.
- (4) Slacken the demister and water hose clips.
- (5) Withdraw the screws securing the unit to the parcel shelf and remove.

Section R.4**QUARTER-LIGHT GLASSES****Removing (Fixed type)**

- (1) Support the outside of the glass and hit it with the palm of the hand inside at the top, then remove the glass and rubber.

Refitting

- (2) Fit the surround rubber to the glass.
- (3) Pass a length of thin cord round the outer channel of the surround, leaving the ends hanging down on the inside of the glass.

Refitting

- (6) Reverse the removal instructions.
- (7) Open the heater tap on the rear of the engine and refill the cooling system.
- (8) Test the heater; if the water return hose does not warm up in a few minutes, there may be an air lock.
- (9) To clear, disconnect the return hose from the lower radiator hose and plug the hole.
- (10) Extend the return hose to reach the radiator filler.
- (11) Start up and note the flow of water from the return hose; when it is free from bubbles, switch off and reconnect.

Section R.6**ROOF LINER****Removal**

- (1) Disconnect the battery and remove the roof light.
- (2) Mark the position of the rear edge of the front liner on the cant rail.
- (3) Grip the outer edges of the liner and pull it backwards and inwards.
- (4) Mark the position of the front edge of the rear liner and pull it forwards and inwards.

Refitting

Reverse the removal instructions.

Section R.7**DOOR LOCKS****Removing**

- (1) Withdraw the screw securing the lock to the inner panel and the screw from the end of the locking handle spindle.
- (2) Slacken the screw clamping the inner lever and remove the handle and escutcheon.

Refitting

Reverse the removal instructions. Ensure that the inner control cable lever is fitted upright.

Section R.8**DOOR FRAME—REAR
(Countryman and Traveller)****Removing**

- The wood frame is a complete assembly.
- (1) Remove the rear door and take off the lock.
 - (2) Remove the two screws from the centre of the inner door panel.
 - (3) Remove the door sealing rubber and retaining clips.

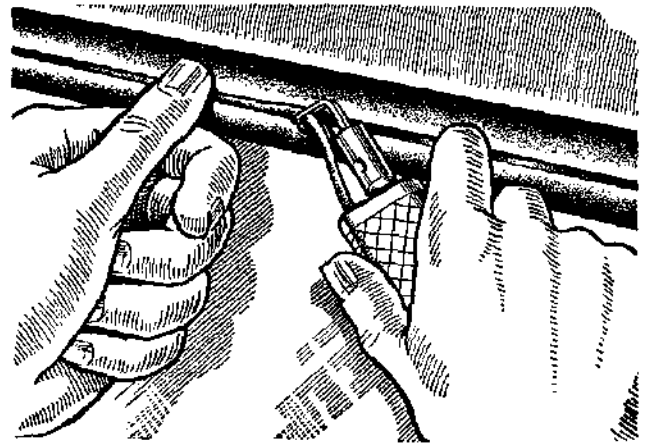

4928

Fig. R.2

The use of the glazing tool and eye to thread the locking filler strip into the rubber channel

- (4) Extract the self-tapping screws from the edge of the door and remove the frame assembly from the panel.

Refitting

- (5) Clean off sealing compound and remake the joints.
- (6) Refit the frame; locate all the screws before tightening any.

Section R.9**SLIDING GLASSES
(Countryman and Traveller)****Removing**

- (1) Remove the trim panel from above the sliding windows.
- (2) Remove the upper channels, support the inside and push the glass from the outside.

Refitting

- (3) Reverse the removal instructions.

Section R.10**TILT FRAME AND COVER
(Pick-up)**

The tilt frame and cover are supplied as a separate kit; the centre and rear hoop sockets, and the front attachment bracket for the struts, are fitted to the vehicle as original equipment.

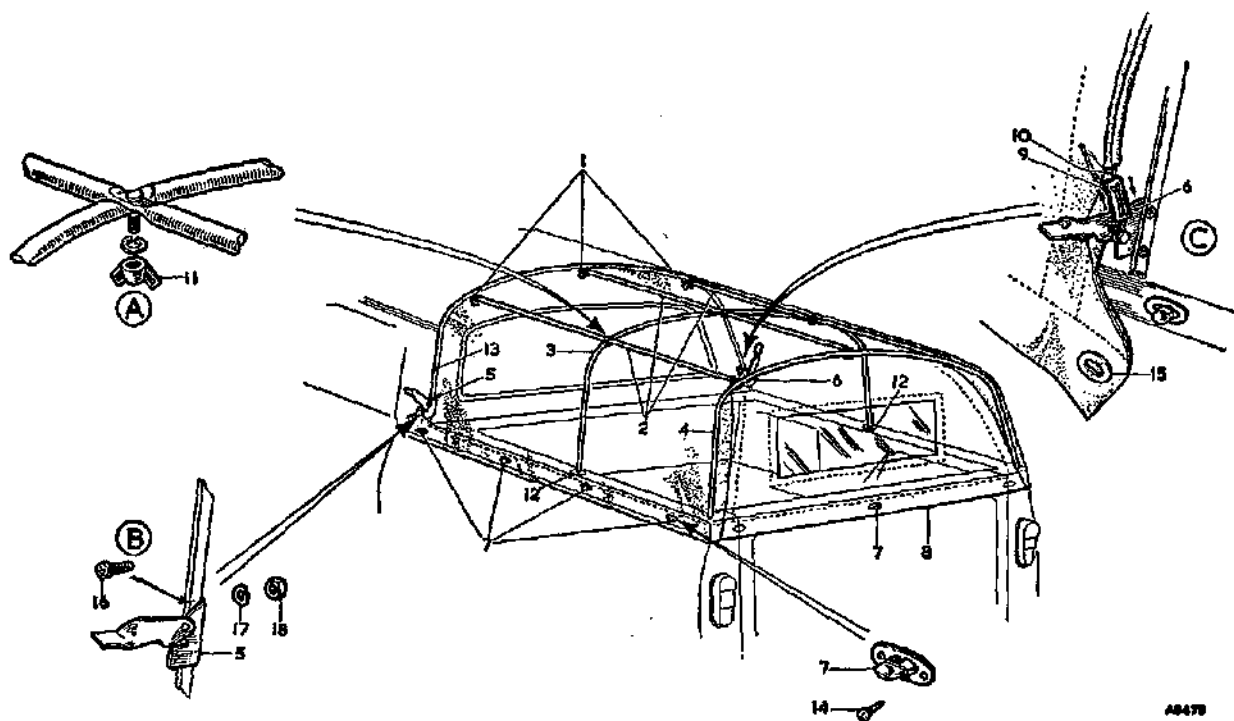

Fig. R.3

The tilt frame and cover assembly

- | | | |
|---------------------------|-----------------------------|-------------------------------------|
| 1. Front fixing brackets. | 7. Turn-button. | 13. Cover retaining channel. |
| 2. Strut. | 8. Cover assembly. | 14. Screw—turn-button to body side. |
| 3. Front hoop. | 9. Adjuster plate—cable. | 15. Eyelet—tilt cover. |
| 4. Rear hoop. | 10. Cover fixing cable. | 16. Screw—lever bracket to body. |
| 5. L.H. lever bracket. | 11. Wing nut—strut to hoop. | 17. Spring washer. |
| 6. R.H. lever bracket. | 12. Hoop housing assembly. | 18. Nut for screw. |

Fitting

- (1) Fit the rear hoop ends into the sockets at either side of the rear end of the body. Ensure that the three brackets attached to the top of the hoop face forwards.
- (2) Fit the centre hoop ends into the sockets at the centre position.
- (3) Engage the studs of one of the struts in the hole in the centre bracket at the top of the rear hoop, the centre hole pierced in the top of the centre hoop, and the hole in the centre bracket attached to the rear of the cab at the top (see Fig. R.3). Fit a spring washer and wing nut to each stud and tighten fully (inset (A) of Fig. R.3).
- (4) Repeat this operation with the other two struts, using the fixing holes in the brackets and centre hoop either side of the central fixing points.
- (5) Place the R.H. lever bracket assembly on the rear face of the channel fixed around the rear of the cab with the drilled face of the bracket against the channel, its lower edge approximately in line with the top edge of the seam (body cross-member to cab). The lever attached to the bracket must face outwards and the lever pin must face forwards.

Mark off the position of the two holes in the

drilled face of the bracket onto the body and drill two holes $\frac{3}{8}$ in. (5-16 mm.) diameter. Fix the bracket to the channel with two of the No. 10 pan-head screws, nuts, and spring washers, the heads of the screws facing outwards (see inset (B) of Fig. R.3). Repeat this operation with the L.H. bracket on the L.H. side of the channel.

- (6) Lay the tilt cover, smooth face upwards, over the tilt frame with the fixing cable at the front.

Arrange the centre longitudinal seam to run centrally along the central strut and the centre transverse seam to be central about the centre hoop.

Lift the levers on the bracket to their fullest extent and hook the fixed loop in one end of the fixing cable over the pin of the corresponding lever.

Ensure that the cable running through the tilt cover is forwards of the rear edge of the channel round the outer edge of the cab for its full length. Adjust the loop at the other end of the cable until it will engage over the pin on its lever without undue slackness in the cable. The adjuster consists of a rectangular plate pierced with four holes. The cable is fed up through one hole from the rear of the plate, and then passed down through the hole below and in line along the length of the plate. The loop is formed below the plate, and the free end of the cable is then threaded through the lower vacant hole

from the bottom face of the plate, and returns down through the corresponding hole at the top. By adjusting the position of the cable in the plate the length of the cable can be varied as necessary (see inset [c] of Fig. R.3).

With both loops engaged over their respective lever pins, press down each lever in turn until it toggles over into its locked position. The cable should now be holding the front of the tilt cover firmly, and must fit snugly down in the retaining channel throughout its length.

When the adjustment of the cable is satisfactory and the cable and tilt cover are seating correctly in the channel, tuck the free end of the cable back into the tilt cover alongside the cable.

- (7) Arrange the tilt cover so that it lies evenly and smoothly over the tilt frame. The fixing position of the turn-buttons can be marked off, using the eyelets in the lower edges of the cover as templates.

Beginning with the extreme front eyelets, adjust the cover so that it takes its natural position and mark around the inside of the eyelet on the vertical face of the body. Hold the base of the turn-button against the body in the position so marked and mark and drill the two fixing holes, using a $\frac{7}{32}$ in. (2.78 mm.) diameter drill. Attach the turn-button to the body with two of the No. 6 countersunk self-tapping screws provided.

Repeat this operation on the remaining turn-button positions, working from front to rear, attaching the cover to the body as the work proceeds. Repeat on the opposite side of the body, then lower the rear flap and mark off, fit the turn-button in the centre of the tailboard in the same manner.

- (8) Loop the short centre strap attached to the under side of the top of the cover around the central strut, and fasten the ends together with the turn-button and eyelet provided. Attach the corners of the rear flap to the side of the cover by means of the turn-buttons and eyelets provided. The two long straps at the top of the cover are for securing the rear flap when it is rolled and out of use.

Section R.11

INSTRUMENT PANEL

(Super De-luxe, Traveller, and Countryman)

COOPER

Removing

- (1) Remove four screws from the front face of the shroud.
- (2) Withdraw the shroud and disconnect the panel light switch wires.

- (3) Disconnect the oil gauge pipe and the temperature gauge wires.
- (4) Remove four screws and withdraw the panel with oil and temperature gauges.
- (5) Unscrew the knurled nuts and remove the gauges.

Refitting

Reverse the removal instructions.

Section R.12

SPEEDOMETER

(Super De-luxe and Cooper)

Removing

- (1) Remove the panel.
- (2) Unscrew two screws and remove the speedometer instrument panel brackets and distance pieces.
- (3) Disconnect the cable from the speedometer.
- (4) Disconnect the fuel gauge cable.
- (5) Pull out the bulb holders from the speedometer.
- (6) Withdraw the speedometer into the engine compartment.

Section R.13

CHECKING BODY ALIGNMENT

(Without Checking Jig)

- (1) Raise the vehicle and support it parallel to a level floor using the comparative measurements given on page R.11 (vertical alignment check).
- (2) Check the relative heights of all the intermediate points for distortion of the vehicle in the vertical plane.
- (3) Chalk the floor below the points shown on page R.12 (horizontal alignment check).
- (4) With a plumb-line, project the checking points from the vehicle onto the floor and mark the position with a pencil.
- (5) Mark the central points between each pair of checking points on the floor.
- (6) Mark the diagonals between any two pairs of points and intersections.
- (7) Stretch a length of chalk-covered cord so that it passes through as many of the marked central points and intersections as possible.
- (8) While the cord is held taut by two operators, a third should raise the cord and allow it to spring back and leave a white line on the floor. Any points through which the resulting white line does not pass will indicate the point where the underframe is out of alignment.

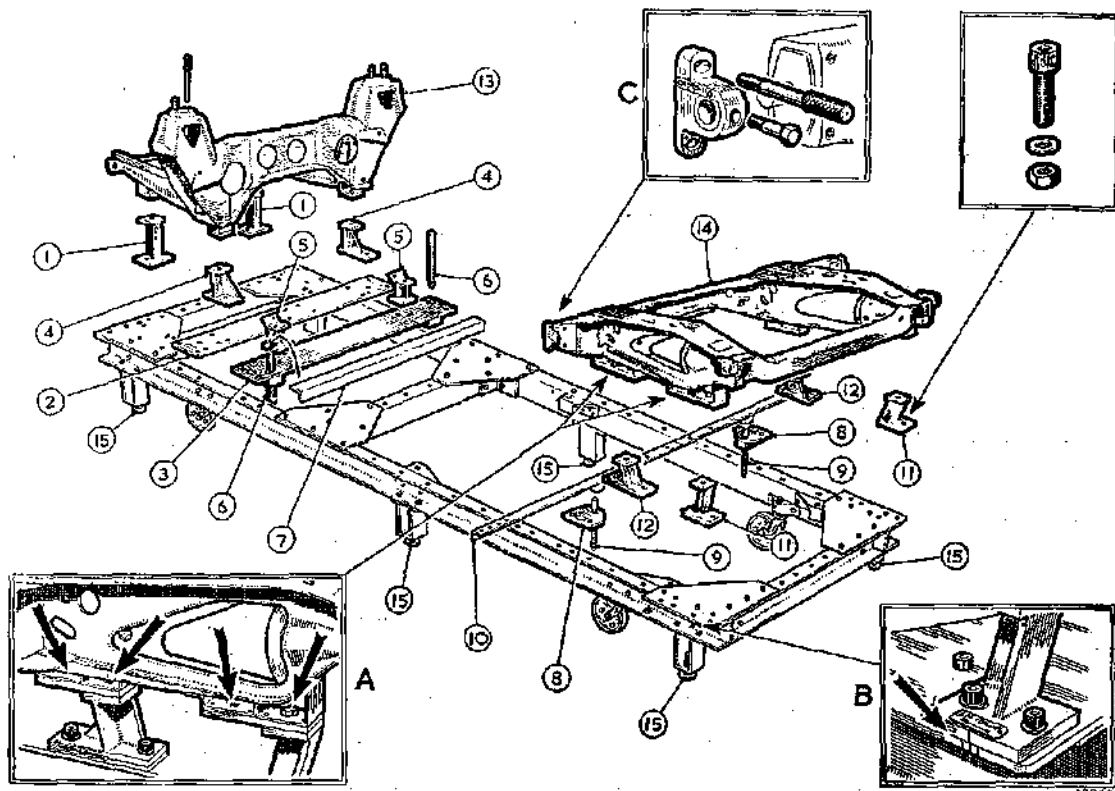

Fig. R.4

The assembly of the jig components

- (9) Considerable deviations in the measurements given on pages R.11 and R.12 confirm body misalignment. Allowance must be made for normal manufacturing tolerances and a reasonable departure from nominal dimensions can be permitted without detriment to performance.

Section R.14

CHECKING BODY ALIGNMENT

(With Checking Jig)

The equipment required for checking the body alignment consists of the basic body checking jig Service tool 18G 560, and adaptor set 18G 560 E used in conjunction with basic adaptor set 18G 560 A.

This equipment is intended to be used solely as a checking fixture, and under no circumstances must any welding or repair work be carried out on the body while it is still in position on the jig.

Assembling the jig

Where item numbers are quoted in this sub-section refer to Fig. R.4.

Remove the two inner socket screws from each corner plate on the front cross-member of the basic jig. Attach the two tall support pedestals (1) from adaptor set 18G 560 E to the cross-member at these points. Each

pedestal is clearly labelled to show its correct location directionally. Fit the plate marked 'Forward 1' (2) from the basic adaptor set 18G 560 A and the plate marked 'Forward 2' (3) from the adaptor set 18G 560 E to the basic jig at the points indicated on the inside of the left hand side-member.

Attach the shorter pair of support pedestals (4) from adaptor set 18G 560 E to the rear of the front checking frame (13). Mount the frame with the rear pedestals on plate 1 (2) and attach the frame to the front pedestals and the rear pedestals to the plate.

Fit the two checking adaptors (5) and the two jacking screws (6) from 18G 560 E to plate 2 (3). Place the short jacking bar (7) from adaptor set 18G 560 in position on the jacking screws.

Attach the two jacking screw brackets (8) from 18G 560 E to the side-member of the basic jig at the position marked 'OX' on the top of the left-hand side member and at the corresponding position on the right-hand side-member.

Screw in the two longer jacking screws (9) from adaptor set 18G 560 A. Assemble the long jacking bar (10) from 18G 560 A and place in position on the screws.

Fit the two support pedestals (11) from 18G 560 E to the rear of the jig corner plates.

Attach the other pair of pedestals (12) from 18G 560 E to the front of the rear checking frame (14) and mount the checking frame on the rear pedestals and the side-member

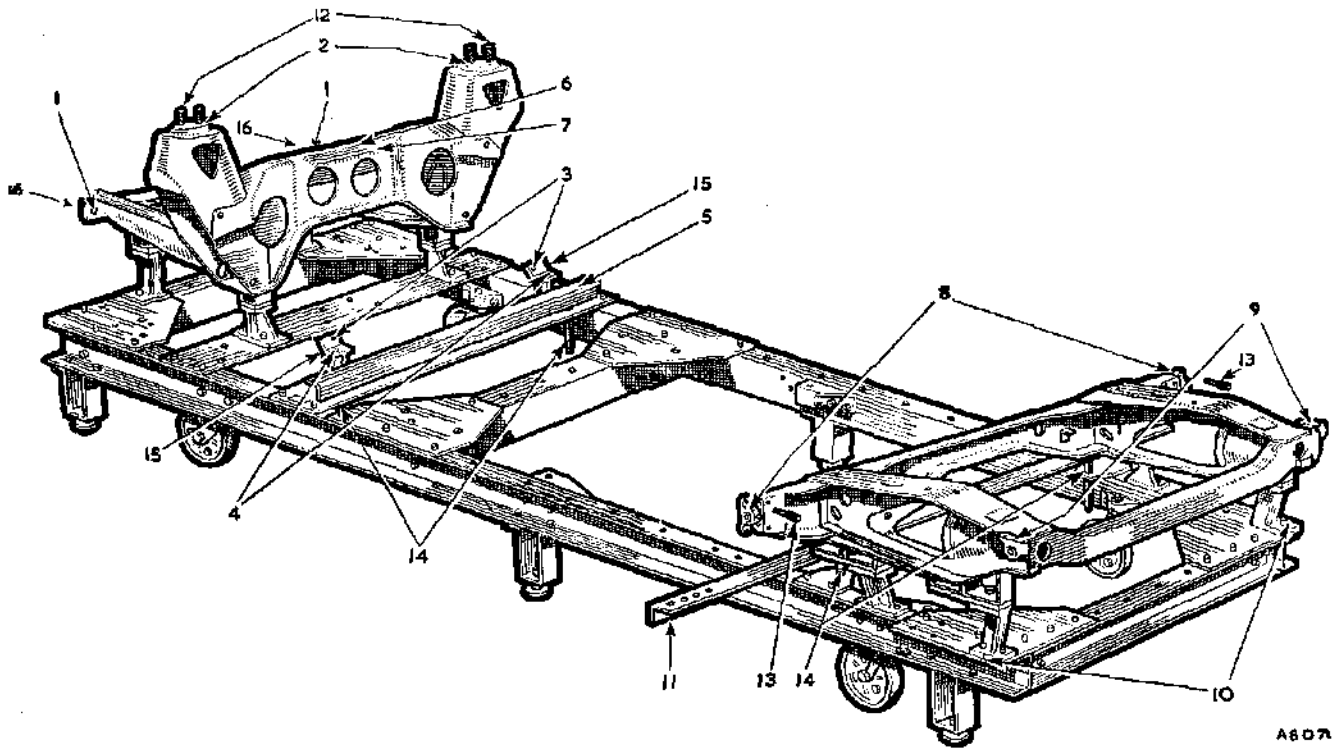

Fig. R.5
The jig checking points

of the basic jig. Do not tighten completely the pedestal to jig fixing bolts.

NOTE.—The rear checking frame has two alternative pairs of holes each side for attachment to the pedestals. The forward pair are for use when checking the body of a Van, Countryman or Traveller, the rear pair are for use when checking a Saloon body (see inset [A]).

When the assembly of the jig and adaptor sets is complete, adjust the basic jig by means of its six adjustable feet (15) (one at each corner, one on each side) until the weight is taken from the castors and the jig is level. Levelling indicators are provided, one on each side-member and one on the front cross-member.

If a fixed-position hoist is to be used to lift the body onto the jig, the jig must be levelled up in a central position under the hoist with the body already raised.

Checking alignment

All item numbers quoted in the following description refer to Fig. R.5.

Remove the four pins with knurled heads (12) from the top checking faces (2) of the front checking frame.

Move the rear checking frame to its most rearward position by means of the slotted holes in the base of the pedestal supports.

Lower the body squarely over the checking frames until it rests on the jacking bars.

At no time must the weight of the body be taken by the checking frames.

Lower the jacking bars equally, keeping the body MINI. Issue 1. 4908

square with the jig, until the body is lightly in contact with the top faces (2) of the front checking frame.

Insert the four pins (12) through the holes in the body and into the holes in the top faces of the front checking frame. Check the relation of the holes in the body to the plain shank of the checking pins. The ideal position is when each of the holes in the body is concentric with the shank of its checking pin (see Fig. R.6). Adjust the body on the jig until this position, or the nearest possible approach to it, has been attained.

Line up the top holes in the front checking brackets (8) of the rear checking frame with the corresponding holes in the body. Insert one of the threaded checking pins (13) in each side to check this alignment.

Move the rear checking frame forward until a parallel clearance of $\frac{1}{8}$ in. (3.18 mm.) is obtained between the forward faces of the front checking brackets (8) and the body (a drill shank is a convenient gauge to use when checking these clearances).

Tighten down the pedestal fixing bolts, and check the relative positions of the lines scribed on the outer edge of each rear pedestal and the lines scribed on either outer edge of the jig rear corner plates (10). The ideal position is when the lines on the pedestals coincide with the central lines on the corner plates (see inset [B], Fig. R.4). The lines scribed either side of each central line show the maximum permissible limits of adjustment, and the correct clearance between the checking bracket and the body must be obtained with the adjustment set within these limits.

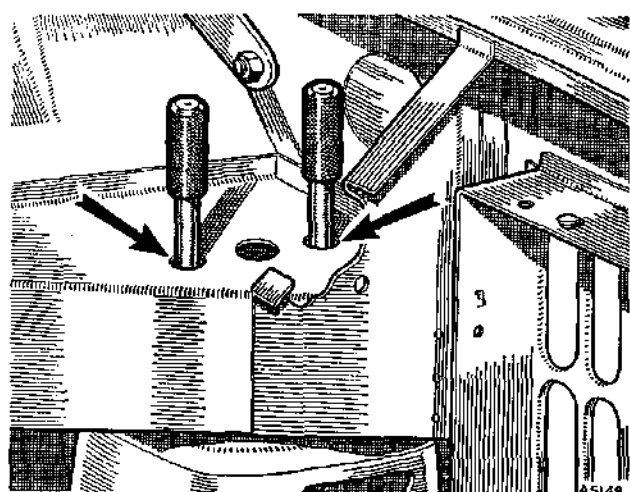

Fig. R.6

Showing an equal clearance around the checking pins with the body correctly aligned

Should the body be damaged in such a way that it is impossible to lower the body on the checking jig with all of the checking brackets on the rear checking frame in position, it is possible to detach either bracket by removing the hexagon-headed dowel bolt passing through the bracket, which can then be pulled off its mounting point.

After the correct location of the body on the jig has been established at the top checking faces on the front frame (2), and at the top holes of the front checking brackets (8) on the rear frame, the remaining alignment points and clearances can be checked.

The two checking holes (1) on the front member of the front checking frame, the four holes on the checking adaptors (3 and 4), and the eight holes in the front and rear checking brackets (8 and 9) on the rear checking frame should all line up by sight with their corresponding holes in the body.

A parallel clearance of $\frac{1}{4}$ in. (6.35 mm.) must exist between the checking faces (16) on the front member of the checking frame and the body and between both faces of each checking adaptor (15) and the under side of the body floor.

Examine the clearance between the body and the front checking frame at all points, including around the sides of the frame towers. If there is a foul at any point, the body must be dressed back until a clearance is obtained.

The face of the cross-member at the rear of the front frame must have a clearance to the body on its top vertical face (6) of $\frac{1}{4}$ in. (3.18 mm.) and $\frac{1}{8}$ in. (1.6 mm.) clearance at the inclined face (7). Should these clearances not be present, the body must be dressed back until the requisite clearance is obtained.

A parallel clearance of $\frac{1}{4}$ in. (3.18 mm.) must exist between the body and the checking faces of the four checking brackets (8 and 9) on the rear checking frame.

R.8

Section R.15

WINDSCREEN (Moke)

Removal

- (1) Remove the windscreen wiper arm and blade.
- (2) Remove four nuts and screws.
- (3) Slacken the bottom retaining screws.
- (4) Lift the frame and glass from the vehicle.
- (5) Remove two screws, detach the bottom channel, and remove the glass from the frame.

Section R.16

HEATER ASSEMBLY (Fresh-air Type)

Removing

- (1) Disconnect the battery and drain the cooling system.
- (2) Remove the front floor covering to avoid damage by coolant when removing the heater pipes.
- (3) Disconnect the two electrical snap connectors below the parcel shelf and the blower switch connection from the ignition switch.
- (4) Remove the demister tube covers, pull off the demister tubes and release the fresh-air intake hose.
- (5) Release the heater water hose clips and pull the hoses from the heater unit.
- (6) Slacken the nut securing the rear of the unit to the bracket, and remove the two screws beneath the parcel shelf securing the front of the heater (Fig. R.7). Lift the unit from the slotted rear brackets, hold the fingers over the matrix pipes and lift the unit out of the car. Drain the coolant from the unit.

On early models the heater unit is secured by four nuts. Lift the parcel shelf trimming and remove the nuts to withdraw the unit; distance pieces are fitted on the mounting studs.

Heater matrix replacement

- (7) Slacken the screws securing the control panel, remove the end cover screws and lift off the cover complete with the blower motor.
- (8) Lift out the heater matrix and fit the replacement unit.
- (9) Reverse the procedure given in item (7).

Heater motor replacement

- (10) Carry out operations (1) to (7).
- (11) Drill out the three Pop rivets securing the motor unit to the end cover and remove the motor.
- (12) Locate the replacement motor in the end cover with the wiring positioned to the top of the heater box when reassembled, and Pop rivet in position.

- (13) Refitting the end cover is a reversal of the removal procedure. Ensure that the flap valve is located on the end cover pivot and operated correctly before refitting the heater to the car.

Blower switch replacement

- (14) Remove the heater control panel and the switch securing nut. Pull the flap valve outwards, withdraw the switch and pull off the wiring connections.
- (15) Fitting a replacement switch is a reversal of item (14).

Refitting

- (16) Reverse the removal procedure and refill the radiator with coolant. Start and warm up the engine, check for leaks and correct operation of the heater assembly. Top up the coolant in the radiator to the correct level.

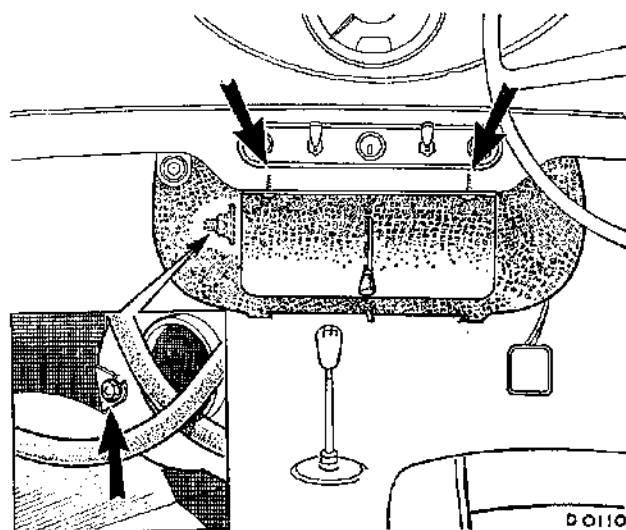

Fig. R.7

The fresh-air heater assembly securing points (arrowed)

Section R.17

INSTRUMENTS

(Mk. II Models)

It is not necessary to withdraw the instrument nacelle to remove the instruments, access to these being from under the bonnet behind the carburetter.

Removing

Speedometer

- (1) Remove the carburetter air cleaner and pull back the sound blanket from the speedometer aperture.
- (2) Disconnect the speedometer cable and pull off the electrical connections from the rear of the instrument. Remove the two securing screws and withdraw the instrument through the aperture into the engine compartment.

Fuel gauge

- (3) Carry out instructions (1) and (2); remove the two securing screws and lift out the fuel gauge.

Oil and temperature gauges

- (4) Carry out instruction (1).
- (5) Disconnect the electrical connections and the oil pressure gauge pipe, unscrew the knurled securing nuts and withdraw the gauges through the nacelle into the car interior.

Refitting

- (6) Refitting or replacing all units is a reversal of the removing procedure.

Section R.18

INSTRUMENT NACELLE

(Mk. II Models)

Removing

- (1) Remove the fascia ashtray and bend up the retaining tab.
- (2) Release the portion of the door seal covering the fascia trim liner and carefully lift the liner which is fixed by adhesive solution to the body. Ease the liner from the fascia sufficiently to gain access to the instrument nacelle securing screws.
- (3) Remove the nacelle securing screws and lift off the nacelle complete with instruments after disconnecting the speedometer cable, oil gauge pipe and the electrical connections (see Section R.17).

Refitting

- (4) Reverse the removing procedure.

THE HEATER ASSEMBLY COMPONENTS (Fresh-air Heater)

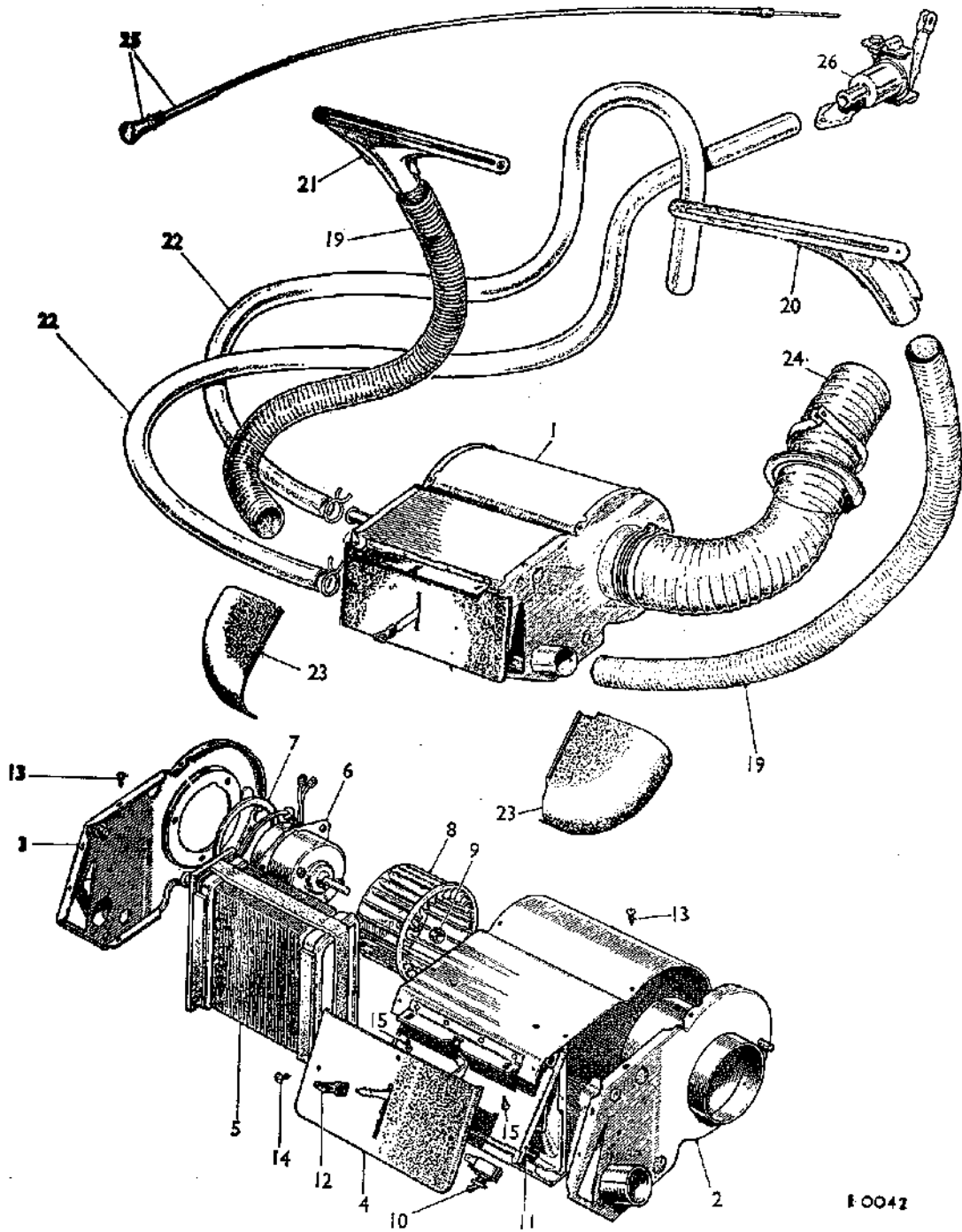

1 0042

- | No. | Description |
|-----|------------------------|
| 1. | Heater unit. |
| 2. | Cover—air intake side. |
| 3. | Cover—motor side. |
| 4. | Control panel. |
| 5. | Matrix. |
| 6. | Motor. |
| 7. | Seal. |
| 8. | Rotor (fan). |
| 9. | Rotor securing ring. |

- | No. | Description |
|-----|----------------------------------|
| 10. | Blower switch. |
| 11. | Flap valve. |
| 12. | Control knob. |
| 13. | Securing screws—side cover. |
| 14. | Securing screws—control panel. |
| 15. | Securing screws—heater assembly. |
| 16. | Securing nut—heater assembly. |
| 17. | Plain washer. |
| 18. | Spring washer. |

- | No. | Description |
|-----|-----------------------|
| 19. | Demister tubes. |
| 20. | Demister duct—R.H. |
| 21. | Demister duct—L.H. |
| 22. | Water hoses. |
| 23. | Covers—demister tube. |
| 24. | Air intake hose. |
| 25. | 'Heat' control cable. |
| 26. | Valve—water control. |

VERTICAL ALIGNMENT CHECK

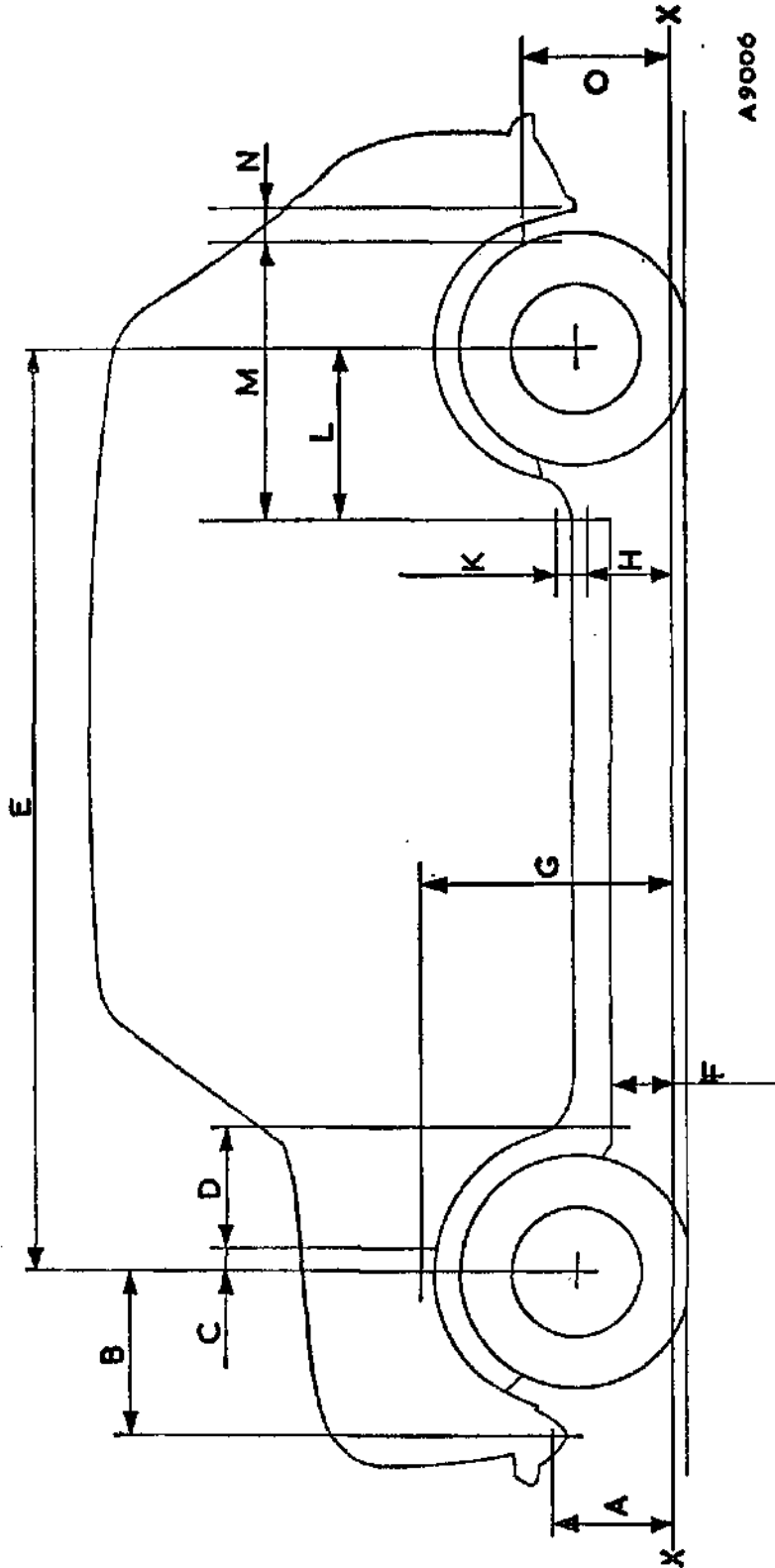

A 9006

| Code Letter | Dimension | Location | Code Letter | Dimension | Location |
|-------------|--|---|-------------|--|---|
| A | 10 ³ / ₁₆ in. (274.64 mm.) | Front sub-frame mounting (front) to wheel centre | H | 8 ³ / ₁₆ in. (212.72 mm.) | Lower rear sub-frame mounting (front) to datum line |
| B | 16 ¹ / ₁₆ in. (423.86 mm.) | Front sub-frame mounting (front) to wheel centre | K | 2 ¹ / ₁₆ in. (57.15 mm.) | Mounting hole centres—rear sub-frame mounting (front) |
| C | 1 ¹ / ₁₆ in. (45.24 mm.) | Wheel centre to tower mounting | L | 14 ¹ / ₁₆ in. (367.11 mm.) | Rear sub-frame mounting (front)—body face to wheel centre |
| D | 10 ⁷ / ₁₆ in. (259.56 mm.) | Front sub-frame mounting (tower) to front sub-frame mounting (extreme rear) | M | 23 ¹ / ₁₆ in. (599.28 mm.) | Rear sub-frame mounting (front)—body face to rear sub-frame mounting (rear) forward fixing hole |
| E | 80 ³ / ₁₆ in. (2036.37 mm.) 84 ¹ / ₁₆ in. (2137.97 mm.) | Saloon Van, Countryman, Traveller, and Pick-up | N | 2 ¹ / ₁₆ in. (57.15 mm.) | Rear sub-frame mounting (rear) fixing hole centres |
| F | 5 ¹ / ₁₆ in. (148.43 mm.) | Body sill to datum line | O | 12 ³ / ₁₆ in. (310.75 mm.) | Rear sub-frame mounting (rear)—body face to datum line |
| G | 20 ³ / ₁₆ in. (523.08 mm.) | Tower mounting (sub-frame) to datum line | | | |

HORIZONTAL ALIGNMENT CHECK

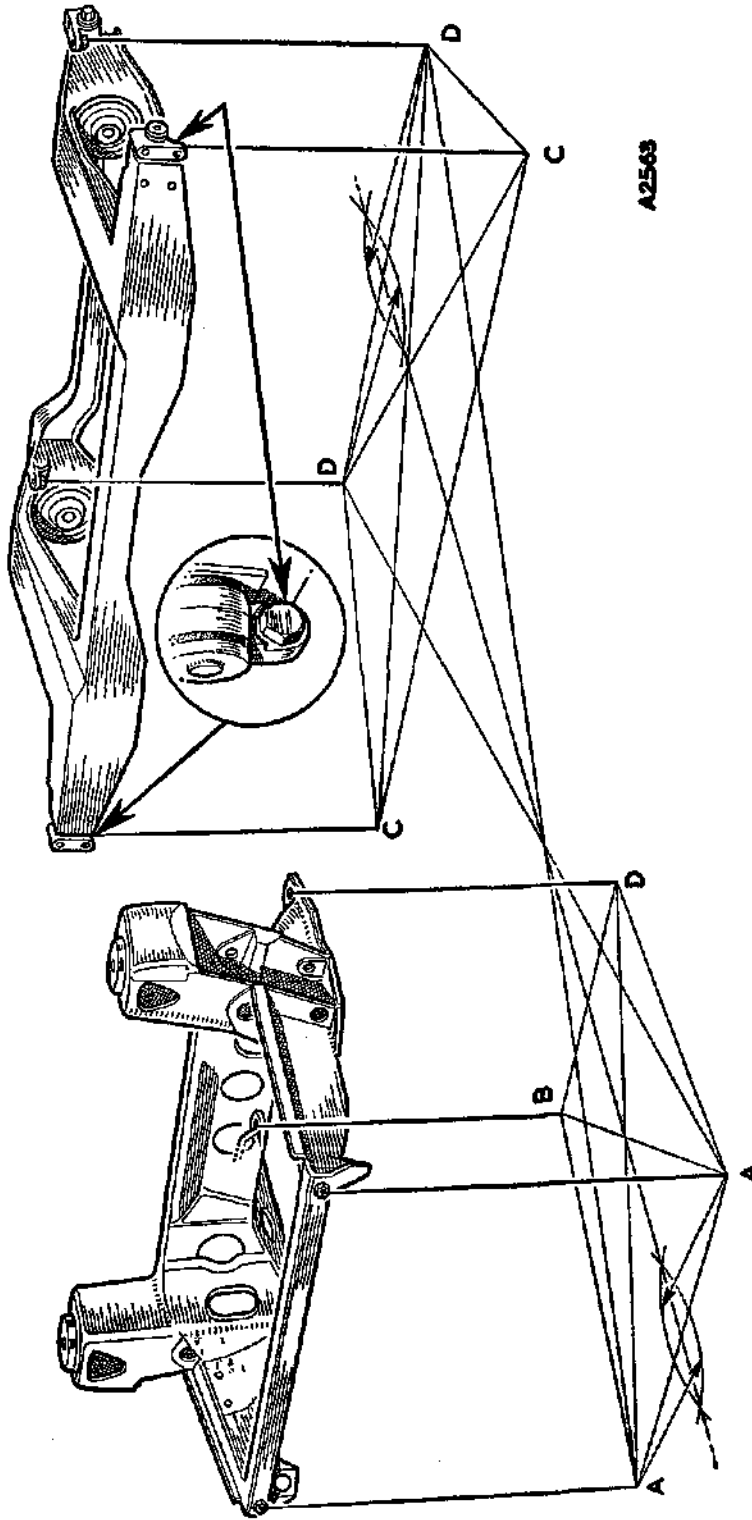

TRANSVERSE DIMENSIONS

| | | | |
|--|---|---|---|
| <p>AA Width between centres of the front sub-frame front mounting set screws 26 in. (660.4 mm.)</p> | <p>BB Width between centres of the front sub-frame rear mounting set screws 16½ in. (412.75 mm.)</p> | <p>CC Width between centres of the rear sub-frame front mounting block lower set screws 50½ in. (1282.7 mm.)</p> | <p>DD Width between centres of the rear sub-frame rear mounting block set screws 38¼ in. (977.9 mm.)</p> |
|--|---|---|---|

A preliminary check of the alignment can best be carried out by the system of diagonals and measurement checks from points projected onto a level floor by means of a plumb-bob.

A centre-line can then be established by means of a large pair of compasses and any deviation from correct alignment will be evident by failure of the diagonals to intersect on the centre-line or by considerable deviations in the measurements.

SUB-FRAME ALIGNMENT DIAGRAM

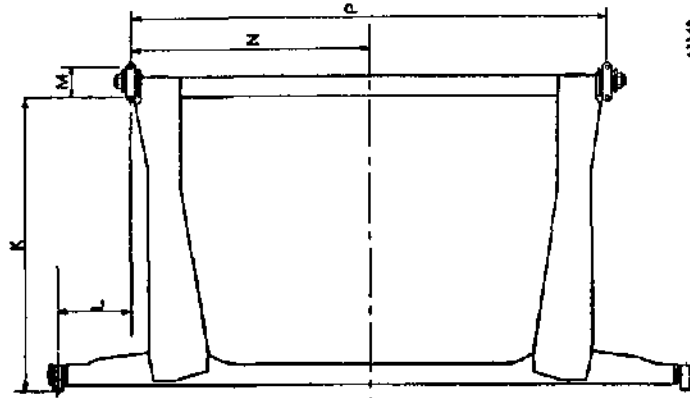
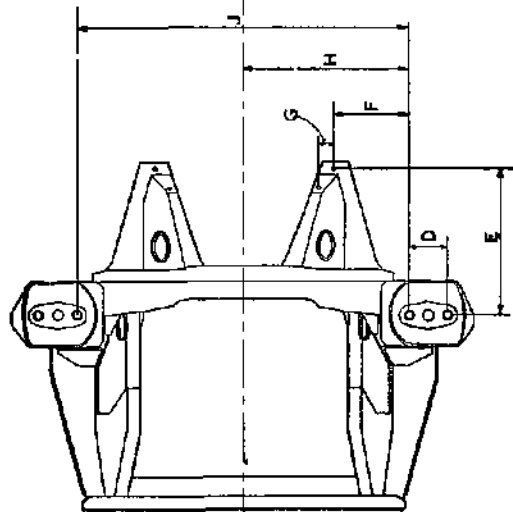
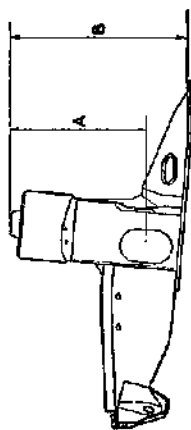

43349

KEY TO DIMENSIONS

- | | | | |
|----|---|----|---|
| A. | 10 1/8 in. ± 0 in. (276.62 mm. ± 0 mm.). | L. | 6 in. ± 0.10 in. (152.4 mm. ± 2.54 mm.). |
| B. | 14 1/2 in. ± 0 in. (374.45 mm. ± 0 mm.). | M. | 2 1/2 in. ± 0.10 in. crs. (57.15 mm. ± 2.54 mm.). |
| C. | 2 1/2 in. ± 0.10 in. crs. (57.15 mm. ± 2.54 mm.). | N. | 19 1/4 in. ± 1/8 in. (488.75 mm. ± 800 mm.). |
| D. | 3 in. ± 0.10 in. crs. (76.20 mm. ± 2.54 mm.). | P. | 38 1/2 in. ± 0.10 in. (977.5 mm. ± 2.54 mm.). |
| E. | 10 1/8 in. ± 1/8 in. (259.56 mm. ± 800 mm.). | | |
| F. | 5 1/2 in. ± 0.10 in. (139.7 mm. ± 2.54 mm.). | | |
| G. | 1 1/2 in. (38.10 mm.). | | |
| H. | 13 1/2 in. ± 1/8 in. (346.08 mm. ± 800 mm.). | | |
| I. | 27 1/2 in. ± 0.10 in. (692.55 mm. ± 2.54 mm.). | | |
| K. | 23 1/2 in. ± 1/8 in. (598.88 mm. ± 800 mm.). | | |



SECTION Rb

THE BODY

The information contained in this Section refers specifically to new or modified components fitted to the Mini range coincident with the introduction of NEGATIVE earth electrical systems and must be used in conjunction with Section R.

| | <i>Section</i> |
|--|----------------|
| Bumpers | Rb.1 |
| Door glass | Rb.8 |
| Door glass channel | Rb.10 |
| Door glass regulator | Rb.9 |
| Door locks (Operation, Adjustments, Lubrication) | Rb.5 |
| Door locks (Removing and Refitting) | Rb.6 |
| Exterior door handles | Rb.7 |
| Fresh-air ventilation (Fascia louvres) | Rb.4 |
| Front grille | Rb.2 |
| Heater unit | Rb.3 |
| Roof lining (Mini Saloon Range) | Rb.11 |
| Roof liners (Mini Clubman Estate) | Rb.12 |
| Seat belts: Automatic (central console type) | Rb.13 |
| Static (central console type) | Rb.14 |
| Rear (when fitted) | Rb.15 |

Section Rb.1

BUMPERS

Removing

Front

- (1) From beneath the wings, remove the two bolts securing each end of the bumper.
- (2) Remove the under-riders (secured by four bolts inside the front valance). Unscrew the remaining two bumper securing bolts and remove the bumper.

Rear

- (3) Remove the four securing screws from the under side of the bumper and remove it.

Refitting

Front and rear

- (4) Reverse the removing instructions.

Section Rb.2

FRONT GRILLE

Removing

- (1) Remove the headlamp/grille extension panels (four screws securing each panel).
- (2) Remove the grille panel securing screws and lift the panel out of the locating holes in the lower grille panel assembly.

Refitting

- (3) Engage the lower attachment strips on the panel into the locating holes in the lower grille panel; the remainder is a reversal of the removing procedure.

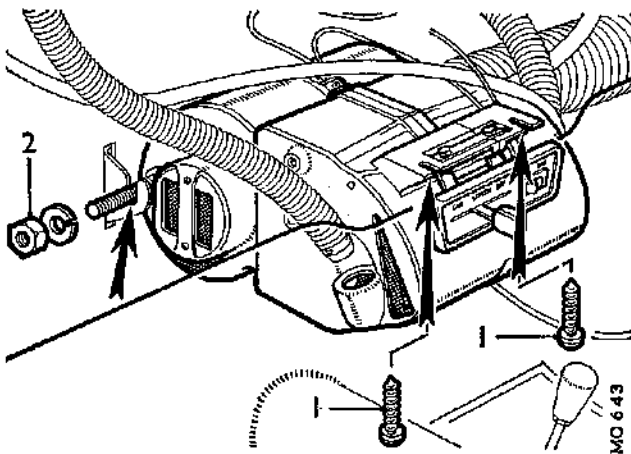

Fig. Rb.1

The heater unit securing points (arrowed)

Section Rb.3

HEATER ASSEMBLY

Removing

- (1) Drain the cooling system (Section C.1).
- (2) Remove the front floor covering to avoid damage by coolant when disconnecting the heater pipes.
- (3) Pull the demister and air intake tubes out of the heater unit.
- (4) Remove the two screws (1) securing the front of the heater and slacken the nut (2) securing the rear of the unit (Fig. Rb.1).
- (5) Disconnect the electrical connections from the blower motor and switch.
- (6) Disconnect the heater water hoses, hold the fingers over the matrix pipes and lift the heater from the slotted rear bracket and out of the car. Drain the coolant from the heater.

Dismantling

Heater matrix replacement

- (7) Remove the blower switch/air distribution panel (two screws), lever off the clips securing the twin casings and separate the unit (see page Rb.3).
- (8) Withdraw the matrix, clean the casings and fit the replacement unit.

Blower motor replacement

- (9) Carry out operations (1) to (7).
- (10) Remove the motor assembly, withdraw each rotor from the unit and fit them to the replacement motor. Remove and connect the electrical wiring to the new unit.
- (11) Refit the unit into the heater casing.

Blower switch replacement

- (12) The blower switch can be removed without removing the heater unit as follows:
From behind the blower switch/air distribution panel, pull off the electrical connections, and using a pair of pliers, press in the retainers on each side of the switch and manoeuvre the switch through the face of the panel.
- (13) Press in the replacement switch and refit the electrical connections.

Refitting the heater

- (14) Reverse the removing procedure and refill the cooling system. Start and warm up the engine, check for leaks and correct operation of the heater. Top up the coolant in the radiator to the correct level.

THE HEATER UNIT COMPONENTS

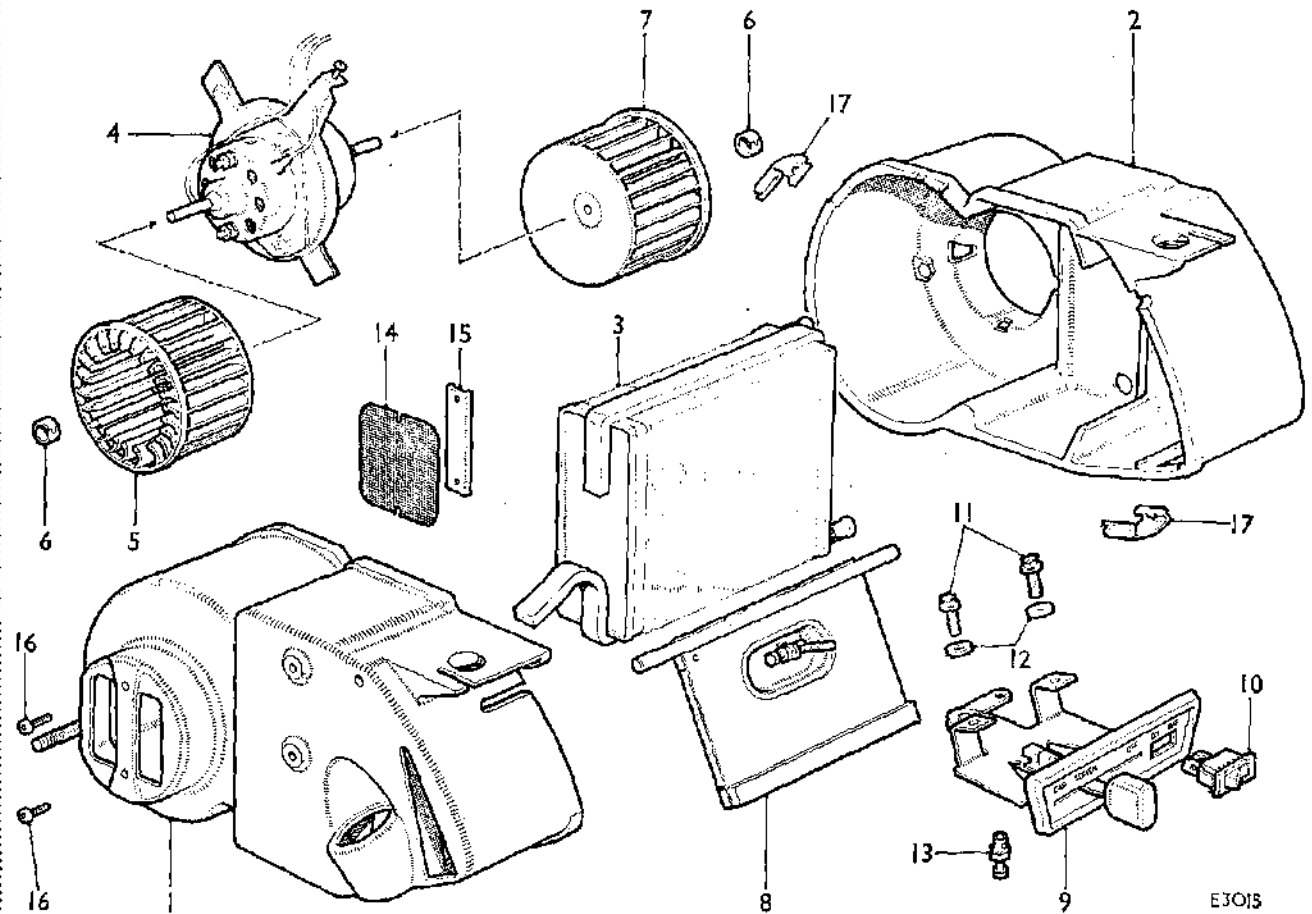

E3015

No. Description

- 1. Heater casing.
- 2. Heater casing.
- 3. Matrix.
- 4. Blower motor.
- 5. Rotor (recirculatory).
- 6. Rotor securing clips.
- 7. Rotor (air intake).
- 8. Air distribution flap.
- 9. Heater control panel.

No. Description

- 10. Blower switch.
- 11. Securing screws—control panel to casing.
- 12. Washers for item (11).
- 13. Trunnion and screw—control lever to flap.
- 14. One-way valve.
- 15. Valve securing plate.
- 16. Valve securing screws.
- 17. Heater casing joining clips.

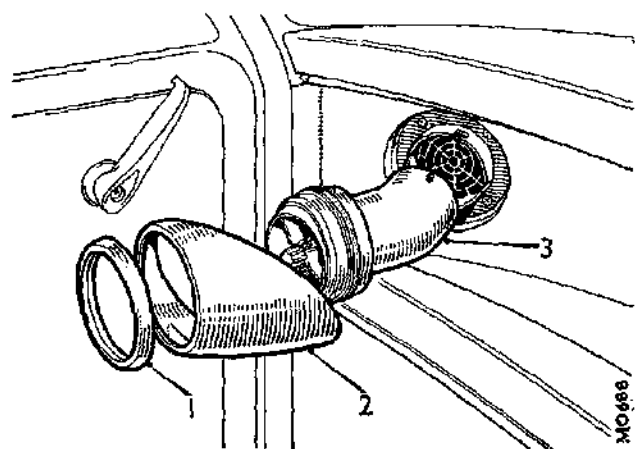

Fig. Rb.2

Removing a fresh-air ventilating louvre

1. Retaining ring. 2. Moulding. 3. Louvre.

Section Rb.4

FRESH-AIR VENTILATION (Fascia Louvres)

Removing Louvres

- (1) Unscrew the louvre moulding retaining ring and remove the moulding (Fig. Rb.2). Turn the ventilation louvre anti-clockwise and withdraw it.

Intake hoses

- (2) From beneath the wing, pull off both ends of the hose(s) from their respective units and remove the hose(s).

Refitting

- (3) Reverse the removing procedures.

Section Rb.5

DOOR LOCKS (Operation, Adjustments, Lubrication)

Before attempting to remove any part of the mechanism because of faulty operation first check that the condition is not caused by bad installation.

Operation

- (1) Wind the window down and close the door.
- (2) Move the interior locking latch rearwards to the locked position. Check that the exterior handle push-button is inoperative and that the door is locked.
- (3) To unlock the door, insert the key and turn it one-quarter of a turn towards the rear of the car; open the door by depressing the exterior handle push-button.

Rb.4

- (4) Close the door and re-open it using the interior release lever.

NOTE.—The interior locking latch cannot be set in the locked position while the door is open.

Adjustments

Push-button plunger

This is preset during manufacture to provide free button movement before the latch contactor (1) begins to operate and release from the striker before full depression (see Fig. Rb.3). However, if further adjustment of the plunger screw is required proceed as detailed below:

- (5) Remove the exterior door handle (see Section Rb.6).
- (6) Adjust the plunger screw and ensure that when the handle is refitted there is a clearance of approximately $\frac{1}{16}$ to $\frac{1}{8}$ in. (1 to 1.5 mm.) between the head of the screw and the contactor mechanism.

IMPORTANT.—The plastic bush immediately under the head of the screw must not be screwed in fully against the plastic push-button stem or the lock link cannot be operated.

Striker unit

Before attempting to close the door ensure that the latch disc is in the open position; if not, 'fire' the latch (using the push-button) and pull the latch disc back to the open position using a screwdriver. Do not slam the door while making adjustments as the mechanism may be strained. The striker screws (1) (see Fig. Rb.4) should be tightened sufficiently to allow the door to be closed to the fully latched position, but will allow the striker

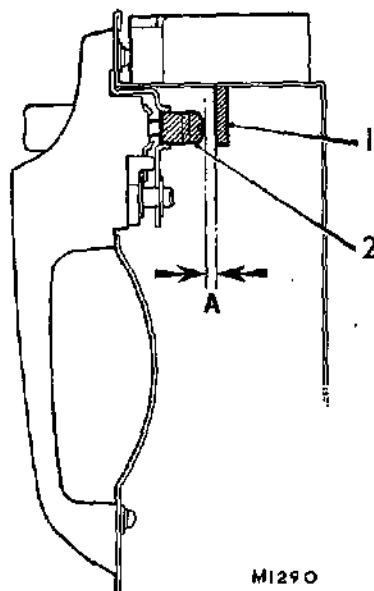

Fig. Rb.3

Door handle push-button plunger adjustment

1. Latch contactor. 2. Push-button plunger screw.
'A' = $\frac{1}{16}$ to $\frac{1}{8}$ in. (1 to 1.5 mm.)

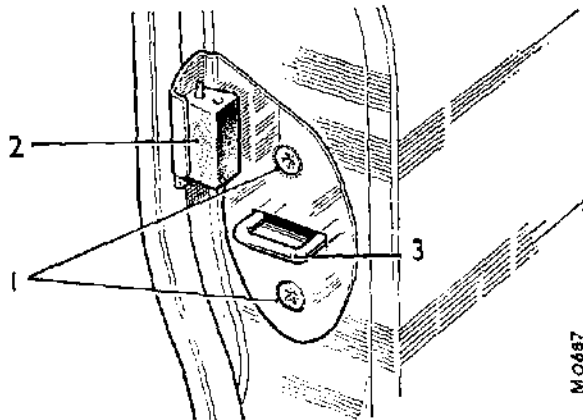

Fig. Rb.4

The door striker unit

1. Securing screws.
2. Over-travel stop
3. Striker loop.

to move with the door as the door is aligned with the body.

- (7) Pull the door outwards or press it inwards (without using the press-button) until the door is in alignment with the body.
- (8) Use the push-button to open the door and pencil a line around the striker cover-plate to establish its new horizontal position.
- (9) Remove the striker plate over-travel rubber stop (2) as this tends to twist the striker during adjustment (see Fig. Rb.4).
- (10) Set the striker loop (3) at right angles to the door hinge plane before finally tightening the screws (1) (see Fig. Rb.4). The door can then be checked for 'drop' or 'lift' and if necessary the striker screws slackened again while the striker is moved vertically as required.

Positioning is carried out by a process of trial and error, until the door can be closed easily without rattling and no lifting or dropping of the door is apparent. When the door is closed it should be possible to press it in fractionally against its seals beyond the latched position thus ensuring that the striker is not set too far in.

Lubrication

The latching elements are enclosed and apart from initial lubrication during manufacture will need no further attention.

- (11) Smear with grease any moving parts of the door latch locking and release mechanism connecting points.
- (12) After assembly, introduce a few drops of 'Loclube' or a thin machine oil into the key slots.

Section Rb.6

DOOR LOCKS

Removing

- (1) Remove the interior release handle, window regulator handle, and the door trim panel. Pull back the adhesive strip adjacent to the lock.
- (2) Remove the screws securing the latch unit and the lock remote control (Fig. Rb.5).
- (3) Remove the interior locking control securing screws (Fig. Rb.5).
- (4) Pull or carefully prise the bottom of the key-operated lock link (3) off the latch locking rod (4) (see Fig. Rb.6).
- (5) Ease the latch outwards, remove the circlips securing the remote control (1) and the interior locking lever (2) to the latch (see Fig. Rb.6) and withdraw both units and the latch from the door frame.

Fig. Rb.5

Removing the latch (1), interior locking control (2), and remote control (3)

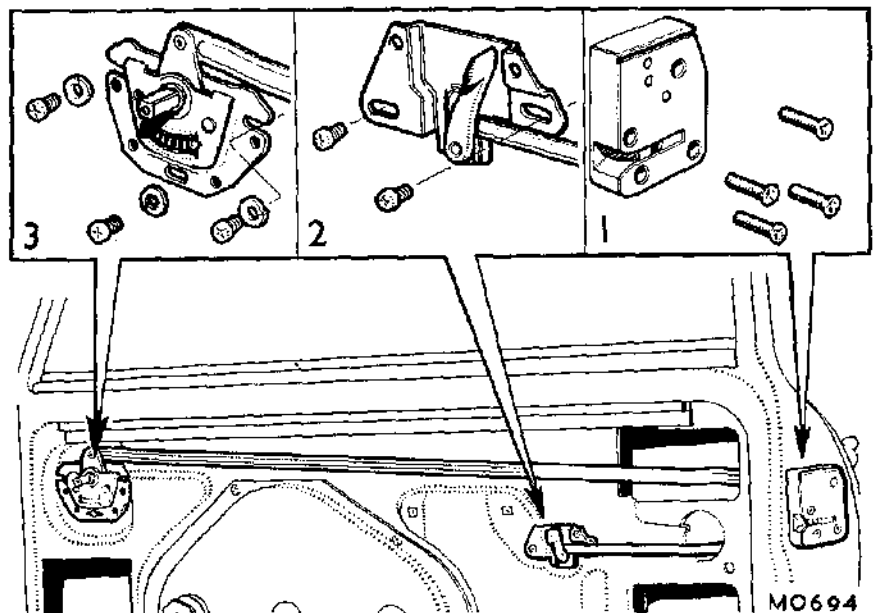

MO694

Rb.5

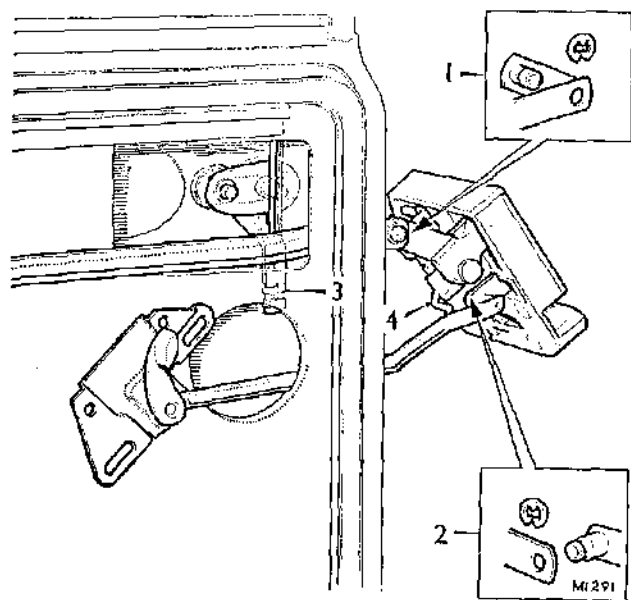

Fig. Rb.6

Showing the locking latch connections

- | | |
|------------------------------|-------------------------------|
| 1. Remote control. | 3. Exterior handle lock link. |
| 2. Interior locking control. | 4. Latch locking rod. |

Refitting

- (6) Reverse the removing procedure, with particular attention to the following instructions.
- (7) Refer to Fig. Rb.6. Ensure that the circlip securing the remote control lever (1) and the interior lock control lever (2) are correctly located, and that the latch locking rod (4) is engaged in the spring clip of the exterior handle lock link (3).
- (8) Check the adjustment of the push-button plunger; see 'Adjustments' in Section Rb.5.
- (9) Refit or fit new adhesive sealing strips to the door panel. Check the door lock operation before refitting the trim panel.
- (10) The door striker-plate can be repositioned if required, see 'Adjustments' in Section Rb.5.

Section Rb.7

EXTERIOR DOOR HANDLES

Removing

- (1) Remove the interior handles, door trim, and latch assembly—Section Rb.6, operations (1) to (5).
- (2) Wind up the window, remove the exterior handle securing screws (Fig. Rb.7), and withdraw the handle from the door.

Refitting

- (3) Reverse the removing procedure, with particular attention to instructions (7) and (8) as detailed in Section Rb.6.

Section Rb.8

DOOR GLASS

Removing

- (1) Remove the interior release handle, the window regulator handle, and the door trim panel. Pull off the adhesive sealing strips where necessary.
- (2) Remove the outer and inner waist rail finishers (Fig. Rb.8).
- (3) Remove the regulator assembly securing screws and use the regulator handle to raise the door glass approximately one-half of its travel (Fig. Rb.8), and use a wooden wedge or block to maintain this position whilst removing the regulator.
- (4) Lever the regulator assembly slightly away from the door panel and turn the regulator handle until the arms are in the vertical position (see Fig. Rb.8). The regulator arms can now be disengaged from the glazing channel by moving the regulator towards the front of the door until the rear arm is free and then moving it rearwards to release the other arm.
- (5) Release the wedge on the door glass, turn the glass as shown in Fig. Rb.8 and remove it from the door.

Refitting

- (6) Reverse the removing procedure, with particular attention to the following instructions.
- (7) When refitting the door glass, ensure that it is located in the glazing channels and wedge it in the position shown in Fig. Rb.8 to facilitate engagement of the regulator arms. Apply sealer around the edge of the regulator plate.
- (8) Ensure that the waist rail securing clips are equally spaced before refitting the finishers.
- (9) When refitting the inner waist rail finisher, butt the forward end against the glazing channel rubber seal before attempting to refit the remainder in position.
- (10) Refit or fit new adhesive sealing strips.

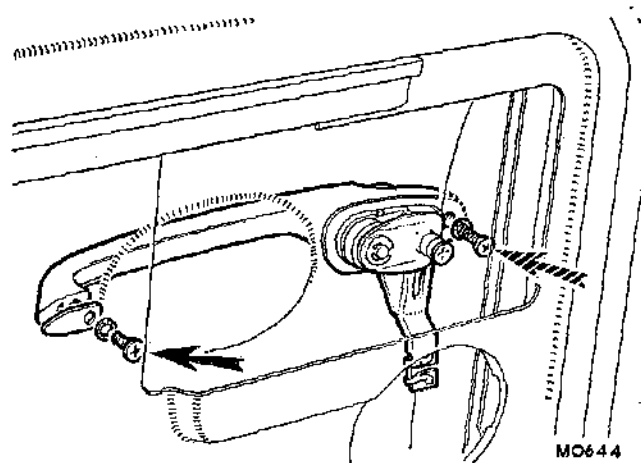

Fig. Rb.7

The exterior handle securing screws (arrowed)

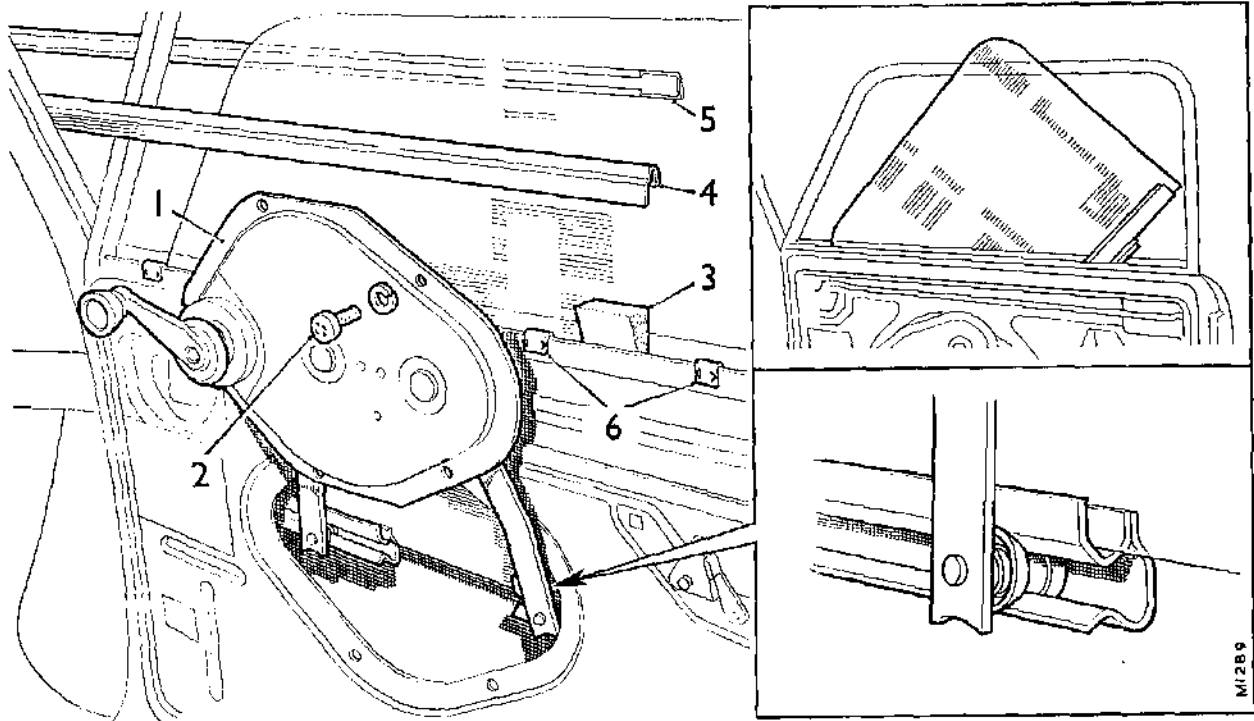

Fig. Rb.8

Removing the door glass regulator, with insets showing the regulator arms and position of the door glass for removal

- | | | |
|-------------------------------|---------------------------------|----------------------------------|
| 1. Regulator unit. | 3. Wedge (to secure glass). | 5. Waist rail finisher (outer). |
| 2. Regulator securing screws. | 4. Waist rail finisher (inner). | 6. Securing clips for finishers. |

Section Rb.9

DOOR GLASS REGULATOR

Removing

- (1) Remove the interior handles, door trim, and regulator assembly—see Section Rb.8, operations (1), (3), and (4).

Refitting

- (2) Apply sealer around the edge of the regulator plate. Ensure that the lip on the front edge of the regulator is engaged inside the door frame. The remainder is a reversal of the removing procedure.

Section Rb.10

DOOR GLASS CHANNEL

Removing

- (1) Follow the instructions given in Section Rb.8 for door glass removal.
- (2) Remove the glazing channel rubber strip and pull the channel from the door frame.

Refitting

- (3) Fit a new glazing channel into the door frame and refit the rubber securing strip.
- (4) The remainder is a reversal of the removal procedure as detailed in Section Rb.8, items (6) to (10).

Section Rb.11

**ROOF LINING
(Mini Saloon range)**

Removing

- (1) Disconnect the battery earth cable.
- (2) Disconnect and remove the roof lamp.
- (3) Remove both front seats and the rear seat squab (to give increased access).
- (4) Remove the sun visors and driving mirror.
- (5) Remove the front and rear screens as detailed in Sections R.1 and R.2.
- (6) Remove the rear quarter-light glass assemblies (hinged or fixed type).
- (7) Release the door seals from around the top of the door apertures.
- (8) The roof lining is secured with adhesive to the roof cant-rail and on the outside flanges of the front and rear screens, door and quarter-light apertures. Release the stuck down areas of the lining, pull the lining towards the front and disengage the lining support rails from the roof cant-rails.
- (9) Before refitting or replacing the liner remove surplus adhesive from the body using white spirit.

Refitting

- (10) If fitting a new roof liner, remove the support rails from the old liner and insert them into the new

Rb.7

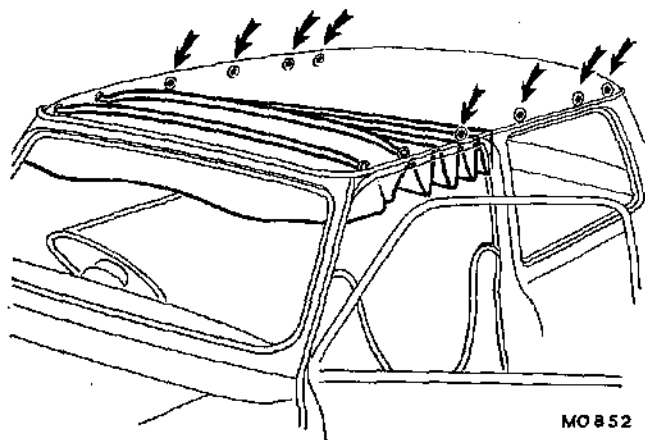

Fig. Rb.9

Fitting the liner support rails into the plastic locators (arrowed) of the roof cant rails

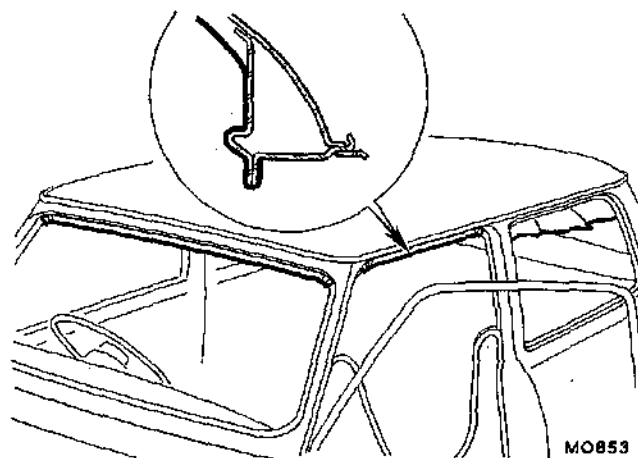

Fig. Rb.10

Cutting and sticking the liner around the screen, door and quarter light exterior flanges

liner; the rails are colour coded and should be fitted in the following order commencing at the front: Nos. 1 (Red), 2, 3 (White), 4 (Black), 5 (Blue), and 6 (Yellow).

On earlier cars the support rails are also colour coded and are fitted from front to rear as follows: Nos. 1 (Red), 2 and 3 (Green), 4 (Blue), and 5 (Yellow).

- (11) Lay out the lining and apply a 4 in. (100 mm.) wide strip of Dunlop adhesive (S914 or S1022) around the edge of the lining.
- (12) Apply the above adhesive to the roof cant rails and to all exterior aperture flanges to which the lining is to be secured.
- (13) Start at the front and engage the liner support rails into the plastic locators in the roof cant rails (see Fig. Rb.9).
- (14) Stretch out the lining front to rear and keeping the lining taut, commence sticking the lining to the front and rear screen aperture flanges and then simultaneously to both roof cant rails.
- (15) Continue cutting and sticking the lining to the door and quarter light exterior flanges and trim off excess material as required.
- (16) Use adhesive when refitting the door seals. The remainder is a reversal of the removing procedure.
- (17) Water test the front screen, back-light, and the rear quarter-light ventilators.

Section Rb.12

ROOF LINERS (Mini Clubman Estate)

Removing

- (1) Disconnect the battery and remove the roof light.
- (2) Mark the position of the rear edge of the front liner on the roof cant-rail.

- (3) Grip the outer edges of the liner and pull it backwards and inwards to withdraw it.
- (4) Remove the trim liner from over the rear doors.
- (5) Mark the position of the front edge of the rear liner and pull it forward and inwards to withdraw it.

Refitting

- (6) Reverse the removing procedure items (1) to (5).

Section Rb.13

AUTOMATIC SEAT BELTS (Central Console Type)

Removing

Reel assembly—Britax belts

- (1) Before removing any belt fixings, attach a clip (1) to the belt just above the reel assembly to prevent the belt retracting during removal and storage. The clip (1) must not be removed until the belt assembly has been refitted, see Fig. Rb.11.
- (2) Withdraw most of the belt webbing from the reel and remove the locking unit retaining screw (3). Lift up the locking unit (4) to expose the reel retaining screw (2). Remove the screw (2) and detach the reel and locating bracket (5), see Fig. Rb.11.
- (3) Remove the screws retaining the belt brackets to the door pillar and sill. Note the assembly sequence of the distance pieces and anti-rattle washers, also the individual lengths of the fixing screws, see Figs. Rb.11 and Rb.12.

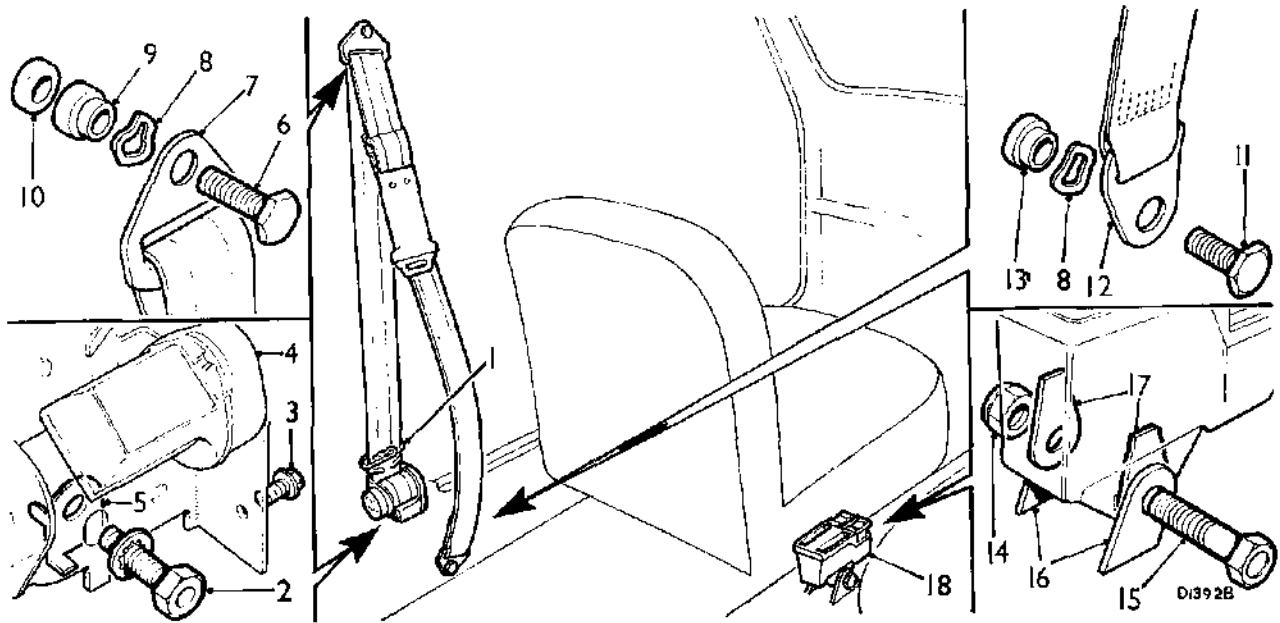

Fig. Rb.11

The Britax 'automatic type' seat belt

- | | | |
|--|---|--|
| 1. Belt restraining clip. | 7. Upper belt bracket. | 13. Shallow shouldered distance piece. |
| 2. Reel retaining screw. | 8. Anti-rattle washers. | 14. Self-locking nut. |
| 3. Locking unit retaining screw. | 9. Deep shouldered distance piece. | 15. Centre console retaining bolt. |
| 4. Locking unit. | 10. Plain distance piece. | 16. Centre console mounting straps. |
| 5. Reel locating bracket. | 11. Lower belt bracket retaining screw. | 17. Fibre washers. |
| 6. Upper belt bracket retaining screw. | 12. Lower belt bracket. | 18. Centre console. |

Reel assembly—Kangol belts

- (4) Remove the reel retaining screw (1) with the plain washer (2) and detach the reel assembly, see Fig. Rb.12.
- (5) Carry out operation (3).

Central console

- (6) Remove the nut and bolt retaining the central console to its mounting straps and detach the console unit.
 Britax: Note that a fibre washer (17) is fitted on either side of the console and is located between the central console and the mounting strap, see Fig. Rb.11.

Mounting brackets—central console

- (7) Remove the carpet to obtain access to the bracket securing screws. Unscrew and remove the two securing screws (1) (with their spring washers) and detach the mounting straps (3), see Fig. Rb.15.

Refitting

- (8) Reverse the order of the removing procedure, noting the following:
 - (a) On the Britax belt use the short retaining screw (11) with the shallow shouldered distance piece (13) when attaching the belt bracket to the sill mounting point.

- (b) Ensure that the reel locking plate is not distorted and that the threaded hole in the anchor plate is in perfect condition.
- (c) The reel must be mounted at an angle of $6\frac{1}{2}^\circ$ from the vertical. This is attained by the reel being mounted onto the locating bracket which has two legs and these engage the holes in the companion box.
 Kangol. Check that the 'arrow' on the side of the reel is pointing vertically. To adjust, slacken the screw (15) adjacent to the arrow, turn the arrow (16) to the vertical position and retighten the screw, see Fig. Rb.12.
- (d) The reel assembly, belt brackets and central console must be refitted with the relevant component parts assembled in the order shown in Figs. Rb.11, Rb.12, Rb.13, and Rb.14.
- (e) All distance pieces must make metal-to-metal contact with the body fixing points.
- (f) Tighten the bolt and nut securing the central console until the unit is lightly gripped between the mounting straps, but can be pivoted with resistance.
- (g) Tighten all belt bracket securing screws to a torque figure of 25 lb. ft. (3.5 kg. m.).
- (h) Tighten the reel locking unit retaining screw (3) Fig. Rb.11 to a torque figure of 5 lb. in. (.06 kg. m.).

NOTE.—If the seat belts were being used whilst the car was involved in a severe impact, the complete belt assemblies must be renewed including the central console, its mounting straps and the reel-to-companion box locating bracket.

Testing

- (9) With the belts being worn, drive the car at 5 m.p.h. (8 km.p.h.) and brake sharply; the automatic locking device should operate and lock the reel.

Section Rb.14

STATIC SEAT BELTS (Central Console Type)

Removing

Belt fixing brackets

- (1) Remove the hexagon screw (1) retaining the belt bracket (2) to the sill mounting point; note the anti-rattle washer (3) and the shouldered distance piece (4), see Figs. Rb.13 and Rb.14.
- (2) Prise out the protective cap (5) covering the hexagon screw (6) at the pillar fixing point. Remove the screw and detach the belt bracket noting the plain washer, parking device, anti-rattle washer and shouldered distance piece on the 'Kangol' belt, and the parking device and shouldered distance piece on the 'Britax' belt, see Figs. Rb.13 and Rb.14.

Central console

- (3) Remove the nut (10) and bolt (11) retaining the central console to its mounting straps (14) and detach the console unit.

Britax. Note that a fibre washer (12) is fitted on either side of the console and is located between the central console and the mounting strap, see Fig. Rb.13.

Mounting straps—central console

- (4) Remove the carpet to obtain access to the strap securing screws. Unscrew and remove the two securing screws (1) (with their spring washers) and detach the mounting straps (3), see Fig. Rb.15.

Refitting

- (5) Reverse the order of the removing procedure, noting the following:
 - (a) All distance pieces must make metal-to-metal contact with the body fixing points.
 - (b) The belt brackets must be refitted with their relevant component parts assembled in the order shown in Fig. Rb.13.
- Tighten the bracket securing screws to a torque figure of 25 lb. ft. (3.5 kg. m.).
- (c) Tighten the central console until the unit is **lightly gripped** between the mounting straps, but can be pivoted with resistance.

NOTE.—If the seat belts were being used whilst the car was involved in a severe impact, the complete belt assemblies must be renewed including the central console and its mounting straps.

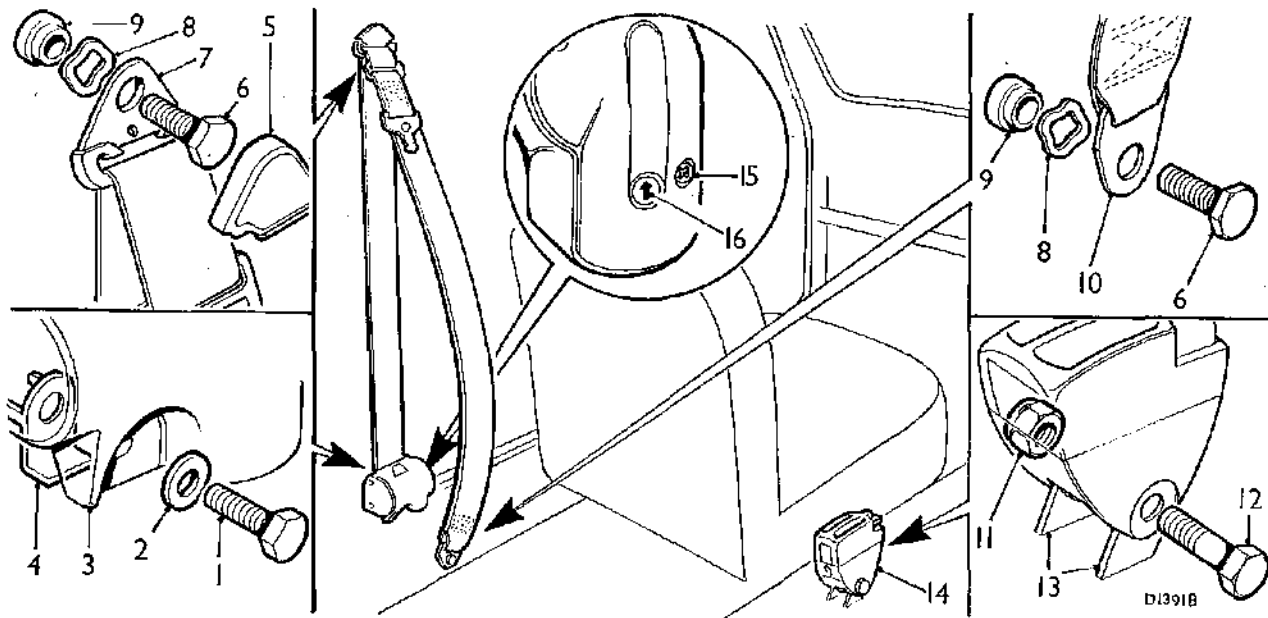
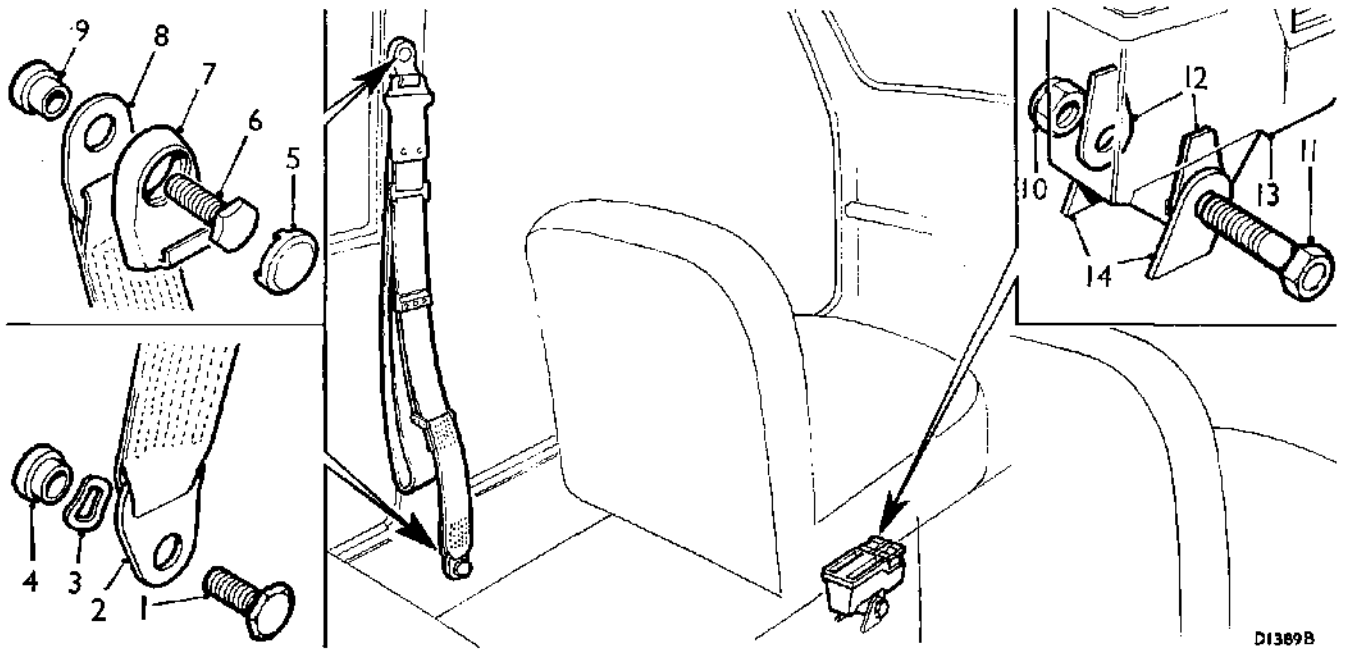

Fig. Rb.12

The Kangol 'automatic type' seat belt

- | | | |
|------------------------------------|---|---|
| 1. Reel retaining screw. | 6. Belt bracket retaining screws. | 12. Centre console retaining bolt. |
| 2. Plain washer. | 7. Upper belt bracket. | 13. Centre console mounting straps. |
| 3. Reel assembly. | 8. Anti-rattle washer. | 14. Centre console. |
| 4. Reel locating bracket. | 9. Distance piece—upper and lower fixing. | 15. Screw—(slacken for arrow adjustment). |
| 5. Plastic cover for upper fixing. | 10. Lower belt bracket. | 16. Vertical adjustment nut. |
| | 11. Self-locking nut. | |



D1389B

Fig. Rb.13

The Britax 'static type' seat belt

- | | | |
|--|--|-------------------------------------|
| 1. Lower belt bracket retaining screw. | 6. Upper belt bracket retaining screw. | 11. Centre console retaining bolt. |
| 2. Lower belt bracket. | 7. Parking device. | 12. Fibre washers. |
| 3. Anti-rattle washer. | 8. Upper belt bracket. | 13. Centre console. |
| 4. Distance piece. | 9. Distance piece—upper fixing. | 14. Centre console mounting straps. |
| 5. Protective cap. | 10. Self-locking nut. | |

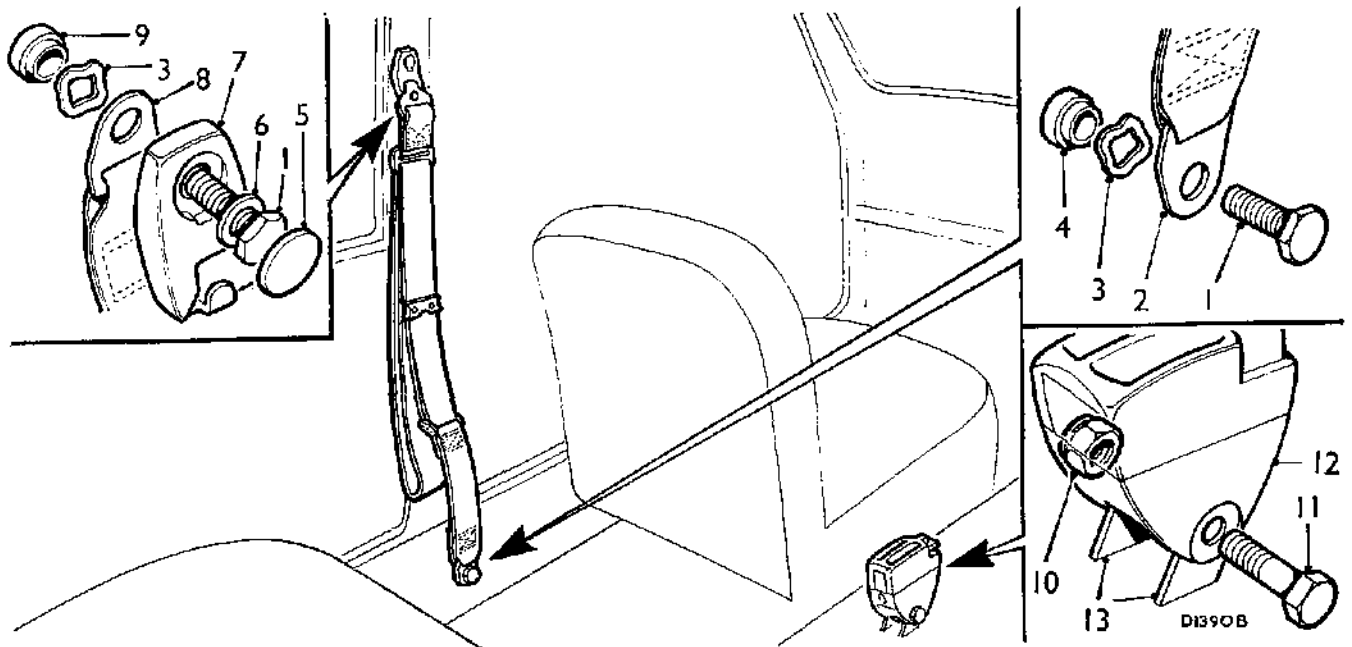

D1390B

Fig. Rb.14

The Kangol 'static type' seat belt

- | | | |
|-----------------------------------|---------------------------------|-------------------------------------|
| 1. Belt bracket retaining screws. | 5. Protective cap. | 10. Self-locking nut. |
| 2. Lower belt bracket. | 6. Plain washer. | 11. Centre console retaining bolt. |
| 3. Anti-rattle washers. | 7. Parking device. | 12. Centre console. |
| 4. Distance piece. | 8. Upper belt bracket. | 13. Centre console mounting straps. |
| | 9. Distance piece—upper fixing. | |

Section Rb.15

REAR SEAT BELTS

(When fitted)

Removing

- (1) Remove the rear seat cushion and squab.
- (2) Remove the belt bracket retaining screws (1) with their spring washers (2), see Fig. Rb.16.

Refitting

- (3) Reverse the order of the removing procedure, noting that the longer section of the belt is fitted to the fixing point nearest to the centre line of the car, see Fig. Rb.16.
- (4) Ensure that a spring washer is fitted under the head of each bracket retaining screw; align the brackets as shown in Fig. Rb.16 and tighten the retaining screws to a torque figure of 25 lb. ft. (3.5 kg. m.).

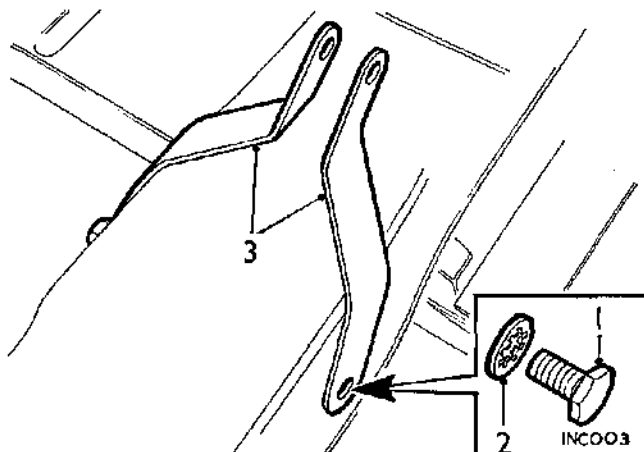

Fig. Rb.15

The centre console mounting straps

1. Securing screw.
2. Lock washer.
3. Mounting straps.

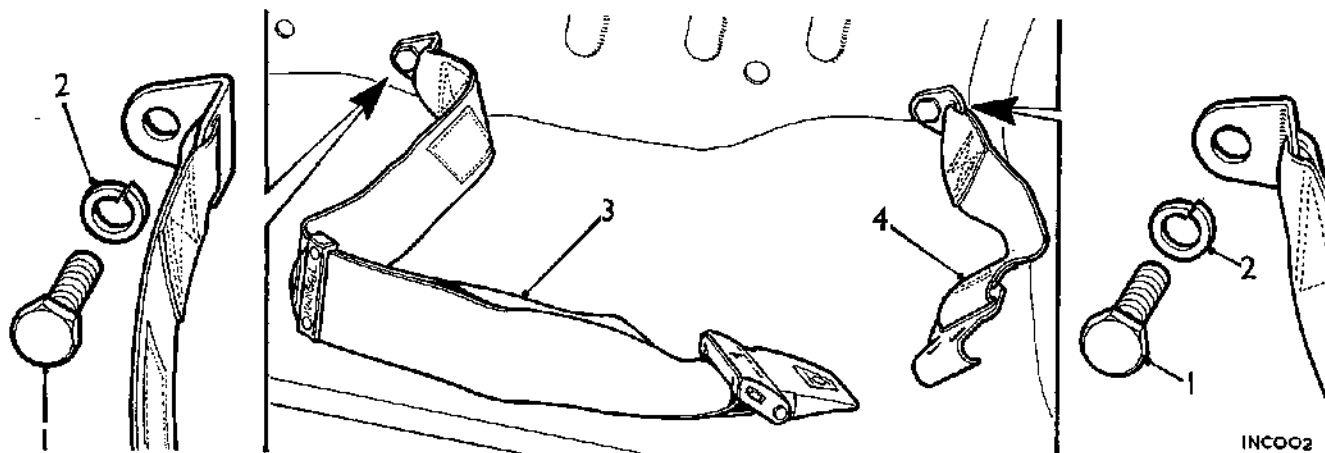

Fig. Rb.16

The rear seat belt mounting points and the belt components

- | | |
|---------------------|--|
| 1. Securing screws. | 3. Belt with buckle fixing (adjustable). |
| 2. Spring washers. | 4. Short belt. |

SECTION S

●All Service tools mentioned in this Manual are only obtainable from the tool manufacturer:

Messrs. V. L. Churchill & Co. Ltd.,
P.O. Box No. 3,
London Road, Daventry,
Northants, England. ●

SERVICE TOOLS

●This Section includes all Service tools for the Mini range of vehicles including the Mini-Cooper, Mini-Cooper 'S' and the 1275 GT. The tools which are only applicable to these models are shown in brackets after the 'Operation' description. ●

| | <i>Operation</i> | <i>Tool No.</i> | <i>Page No.</i> |
|---------------|--|--|---|
| ENGINE | | | |
| | Camshaft liner reaming | { 18G 123 A 18G 123 AH 18G 123 AJ 18G 123 AN | S.7 S.8 S.8 S.8 |
| | Camshaft liner reaming (Cooper and Cooper 'S') | { 18G 123 A 18G 123 B 18G 123 AN 18G 123 AP 18G 123 AT 18G 123 AQ 18G 123 BA 18G 123 BB 18G 123 BC | S.7 S.8 S.8 S.8 S.8 S.8 S.8 S.8 S.8 |
| | Camshaft liner removing and replacing | { 18G 124 A 18G 124 K | S.8 S.9 |
| ● | Camshaft liner removing and replacing (Cooper, Cooper 'S' and 1275 GT) ● | { 18G 124 A 18G 124 B 18G 124 K 18G 124 M | S.8 S.9 S.9 S.9 |
| | Circlip removing and refitting | { 18G 257 18G 1004 | S.10 S.17 |
| | Crankshaft and camshaft gear removing | { 18G 2 18G 98 | S.7 S.7 |
| | Crankshaft primary gear oil seal removing and replacing | { 18G 134 18G 134 BC 18G 1043 18G 1068 | S.9 S.9 S.18 S.18 |
| | Flywheel and clutch removal (coil spring clutch) | { 18G 304 18G 304 M 18G 587 | S.11 S.11 S.15 |
| | Flywheel and clutch removal (diaphragm spring clutch) | { 18G 304 18G 304 N 18G 587 | S.11 S.11 S.15 |
| | Flywheel housing bearing removing and replacing | 18G 617 A | S.16 |

| <i>Operation</i> | <i>Tool No.</i> | <i>Page No.</i> |
|---|---|---|
| Flywheel oil seal replacing | { 18G 134 18G 134 BH | S.9 S.9 |
| Oil pump relief valve seat grinding | 18G 69 | S.7 |
| Piston refitting | 18G 55 A | S.7 |
| ●Piston refitting (Cooper, Cooper 'S' and 1275 GT) | { 18G 55 A 18G 1150 18G 1150 A or 18G 1002 | S.7 S.21 S.17 ● |
| Timing cover oil seal replacing | { 18G 134 18G 134 BD | S.9 S.9 |
| Timing cover refitting | { 18G 138 18G 1044 | S.9 S.18 |
| Torque setting nuts and bolts | { 18G 372 18G 536 18G 537 18G 592 | S.11 S.12 S.12 S.15 |
| Valve removing and refitting | 18G 45 | S.7 |
| Valve grinding-in | 18G 29 | S.7 |
| Valve seat cutting | { 18G 27 18G 167 18G 167 A 18G 167 B 18G 167 C 18G 167 D | S.7 S.9 S.9 S.10 ● S.10 S.10 ● |
| FUEL SYSTEM | | |
| Fuel tank gauge unit removing and refitting | 18G 1001 | S.17 |
| ●Mechanical fuel pump testing | 18G 1116 | S.20 |
| Mechanical fuel pump oil seal removing and replacing | 18G 1119 | S.21 ● |
| CLUTCH | | |
| Clutch dismantling and reassembling (coil spring clutch) | { 18G 304 M 18G 571 | S.11 S.12 |
| Clutch dismantling and reassembling (coil spring clutch—Cooper) | { 18G 304 M 18G 684 | S.11 S.16 |
| Clutch dismantling and reassembling (diaphragm spring clutch) | { 18G 304 N 18G 571 | S.11 S.12 |
| ●Clutch dismantling and reassembling (diaphragm spring clutch—Cooper, Cooper 'S' and 1275 GT) | { 18G 304 N 18G 684 | S.11 S.16 |

| <i>Operation</i> | <i>Tool No.</i> | <i>Page No.</i> |
|---|--------------------------------------|-----------------|
| TRANSMISSION UNIT | | |
| Change speed shaft oil seal replacement | 18G 573 | S.13 |
| Circlip removing and refitting | [18G 257 18G 1004 | S.10 |
| | | S.18 |
| Final drive gear removing and refitting | [18G 586 18G 587 | S.15 |
| | | S.15 |
| First and third motion shaft bearing replacement | 18G 579 | S.14 |
| First motion shaft and bearing removing | [18G 284 18G 284 B | S.11 |
| | | S.11 |
| First motion shaft bearing circlip—checking for correct thickness circlip | 18G 569 | S.12 |
| First motion shaft needle-roller bearing removing and replacing .. | [18G 581 18G 581 B 18G 589 | S.14 |
| | | S.14 |
| | | S.15 |
| ● Idler gear bearing removing and replacing (3-speed synchromesh) .. | [18G 581 18G 582 | S.14 |
| | | S.14 |
| Idler gear bearing removing and replacing (4-speed synchromesh) .. | 18G 1126 | S.21 ● |
| Laygear needle-roller bearing replacement | 18G 194 | S.10 |
| Layshaft reassembly | 18G 471 | S.12 |
| Synchromesh unit assembling | 18G 572 | S.13 |
| Third motion shaft bearing removing (3-speed synchromesh) | 18G 613 | S.15 |
| Third motion shaft bearing removing (4-speed synchromesh) | 18G 1127 | S.20 |
| Torque setting nuts and bolts | [18G 372 18G 536 18G 537 | S.11 |
| | | S.12 |
| | | S.12 |
| DIFFERENTIAL UNIT | | |
| Differential bearing removing and replacement | [18G 2 18G 578 | S.7 |
| | | S.14 ● |
| Drive shaft coupling flange removing and refitting | 18G 669 | S.16 |
| Torque setting nuts and bolts | [18G 372 18G 537 | S.11 |
| | | S.12 |
| AUTOMATIC TRANSMISSION | | |
| Auxiliary pump and governor assembly removing and refitting .. | [18G 1094 18G 1097 18G 1106 | S.19 |
| | | S.20 |
| | | S.20 |
| Converter housing oil seal replacing | [18G 1068 18G 1068 A 18G 1087 | S.18 |
| | | S.18 |
| | | S.19 |

| <i>Operation</i> | <i>Tool No.</i> | <i>Page No.</i> |
|---|--|------------------------------|
| Converter housing removing and refitting | { 18G 1088 18G 1098 | S.19 S.20 |
| Converter removing and refitting | { 18G 587 18G 1086 | S.15 S.19 |
| Differential drive shaft coupling removing | 18G 1100 | S.20 |
| Forward clutch dismantling and reassembling | 18G 1102 | S.20 |
| Forward clutch hub nut removing and refitting | { 18G 1095 18G 1096 | S.19 S.19 |
| Gear carrier assembly dismantling and reassembling (early-type units) | 18G 1093 | S.19 |
| Gear carrier assembly dismantling and reassembling (later-type units) ● | { 18G 284 AJ 18G 1093 A | S.11 S.19 ● |
| Idler and input gears—checking adjustment | { 18G 1089 18G 1089 A | S.19 S.19 |
| Pressure and stall checks | { 18G 677 C 18G 677 Z | S.16 S.16 |
| Converter output gear oil seal removing and replacing | { 18G 134 18G 134 CN | S.9 S.9 |
| Top and reverse clutch dismantling and reassembling | 18G 1103 | S.20 |
| Top and reverse clutch hub removing and refitting | { 18G 1095 18G 1096 | S.19 S.19 |
| Torque setting | { 18G 372 18G 537 18G 592 | S.11 S.12 S.15 |
| DRIVE SHAFTS | | |
| Constant velocity joint—checking ball cage and inner race | { 18G 1012 18G 1099 | S.18 S.20 |
| Drive shaft removing and refitting | { 18G 1063 18G 304 or 18G 304 Z 18G 304 F | S.18 S.11 S.11 S.11 |
| Torque setting | 18G 372 | S.11 |
| REAR SUSPENSION | | |
| Displacer unit or strut removing and refitting | 18G 703 | S.17 |
| Hub bearing outer race removing | { 18G 260 18G 260 C | S.10 S.10 |
| Hub removing | { 18G 304 or 18G 304 Z 18G 304 F | S.11 S.11 S.11 |

| <i>Operation</i> | <i>Tool No.</i> | <i>Page No.</i> |
|---|-----------------------------------|----------------------|
| Hydrostatic suspension—checking pressure | { 18G 685 18G 703 | S.17 S.17 |
| Hydrostatic suspension—depressurizing, evacuating, and pressurizing | 18G 703 | S.17 |
| Radius arm bush reaming | { 18G 588 18G 588 A | S.15 S.15 |
| Radius arm bushes removing and replacing | { 18G 583 18G 584 | S.14 S.15 |
| Radius arm needle bearing removing and replacing | { 18G 583 18G 583 B 18G 620 | S.14 S.15 S.16 |
| Radius arms (Hydrostatic suspension) removing and refitting .. | 18G 703 | S.17 |
| Sub-frame (Hydrostatic models) removing and refitting | 18G 703 | S.17 |

STEERING GEAR

| | | |
|--|-----------------------------------|----------------------|
| ●Steering-column bush (upper) removing and replacing | 18G 1191 | S.21 ● |
| Steering rack dismantling and reassembling | { 18G 207 18G 207 A 18G 707 | S.10 S.10 S.17 |
| Steering rack tie-rod ball joint removal | 18G 1063 | S.18 |
| Torque setting | { 18G 372 18G 537 | S.11 S.12 |

FRONT SUSPENSION

| | | |
|--|---|--|
| Displacer unit or strut removing and refitting | 18G 703 | S.17 |
| Hydrostatic suspension—checking pressure | { 18G 685 18G 703 | S.17 S.17 |
| Hydrostatic suspension—depressurizing, evacuating, and pressurizing | 18G 703 | S.17 |
| Lower arm removal | 18G 1063 | S.18 |
| Spring unit or strut (Rubber suspension models) removing and refitting | { 18G 574 B 18G 1063 | S.13 S.18 |
| Swivel hub joint removing and replacing | { 18G 587 18G 1063 | S.15 S.18 |
| Swivel hub dismantling, fitting bearings, and reassembling | { 18G 304 or 18G 304 Z 18G 304 F 18G 575 18G 260 18G 260 H | S.11 S.11 S.11 S.14 S.10 S.10 |

| <i>Operation</i> | <i>Tool No.</i> | <i>Page No.</i> |
|---|-----------------|-----------------|
| Swivel hub driving flange removing (without dismantling the swivel hub) | 18G 284 | S.11 |
| | 18G 304 or | S.11 |
| | 18G 304 Z | S.11 |
| | 18G 304 F | S.11 |
| | 18G 304 P | S.11 |
| ●Swivel hub oil seal (inner), replacing | 18G 134 DO | S.9 ● |
| Swivel hub outer oil seal replacing | 18G 284 | S.11 |
| | 18G 304 or | S.11 |
| | 18G 304 Z | S.11 |
| | 18G 304 F | S.11 |
| | 18G 304 P | S.11 |
| | 18G 705 | S.17 |
| 18G 705 B | S.17 | |
| Swivel hub removing and refitting | 18G 1063 | S.18 |
| Torque setting nuts and bolts | 18G 372 | S.11 |
| | 18G 537 | S.12 |
| Upper arm (Hydrolastic suspension models) removing, dismantling, and reassembling | 18G 581 | S.14 |
| | 18G 582 | S.14 |
| | 18G 582 A | S.14 |
| | 18G 703 | S.17 |
| | 18G 1063 | S.18 |
| Upper arm (rubber suspension models) removing, dismantling, and reassembling | 18G 574 B | S.13 |
| | 18G 581 | S.14 |
| | 18G 582 | S.14 |
| | 18G 582 A | S.14 |
| | 18G 1063 | S.18 |
| BRAKING SYSTEM | | |
| Brake adjusting | 18G 619 A | S.16 |
| ●Disc brake piston seal replacing (Cooper, Cooper 'S' and 1275 GT) ● | 18G 672 | S.16 |
| BODY | | |
| Body alignment checking | 18G 560 | S.13 |
| ●Existing alternative to 7-700 range. ● | 18G 560 A | S.13 |
| | 18G 560 E | S.13 |
| Body alignment checking (not illustrated) | Churchill 7-700 | |
| ●This jig is available with various adaptors for model ranges. The operating notes supplied with the jig adaptors must be used instead of the instructions given in Section R.14, which refer to the existing jig 18G 560 only. | | |
| Door hinge screws removing and refitting (doors with wind-up windows) | 18G 1188 | S.21 ● |
| Windscreen and back-light glass refitting.. .. . | 18G 468 | S.12 |
| | 18G 468 A | S.12 |



A4933

18G 124 B Camshaft Liner Remover Adaptor

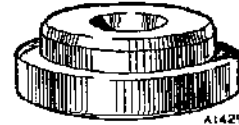

A1429A

18G 134 BH. Flywheel and Front Hub Oil Seal Replacer Adaptor

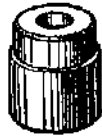

A4933

18G 124 K. Camshaft Liner Remover Adaptor

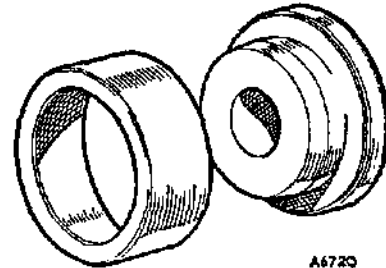

A6720

18G 134 CN. Replacer Oil Seal Stator Carrier



18G 124 M. Camshaft Liner Remover Adaptor

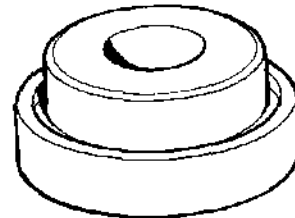

INC537

●18G 134 DO. Swivel Hub Oil Seal Replacer (Inner oil seal with water shield.)●



829XX

18G 134. Bearing and Oil Seal Replacer (basic tool)

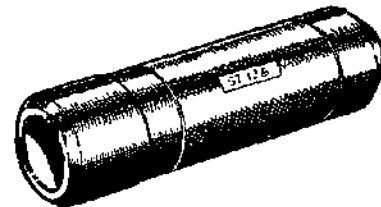

8138

18G 138. Crankshaft Gear and Pulley Replacer

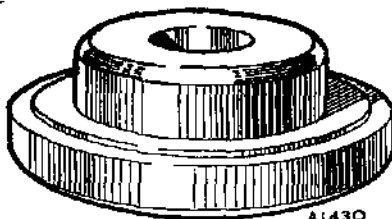

A1430

18G 134 BC. Crankshaft Primary Gear Oil Seal Replacer Adaptor

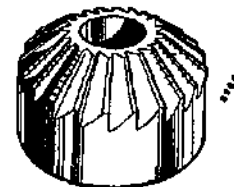

18G 167. Valve Seat Finishing Cutter

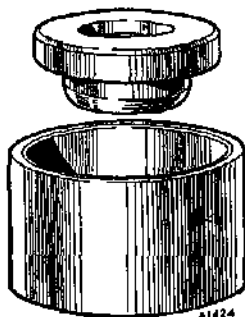

A1424

18G 134 BD. Timing Case Oil Seal Replacer Adaptor

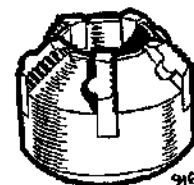

9165A

18G 167 A. Valve Seat Glaze Breaker

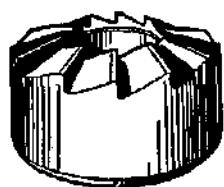

9021B

18G 167 B. Valve Seat Narrowing Cutter—Top

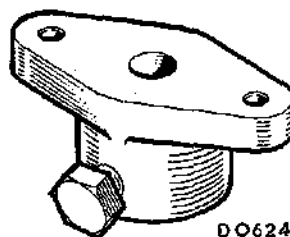

DO624

●18G 207 A. Steering Rack Pinion Preload Adaptor●

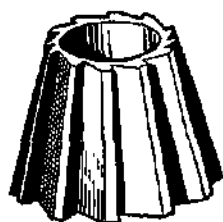

9021A

18G 167 C. Valve Seat Narrowing Cutter—Bottom

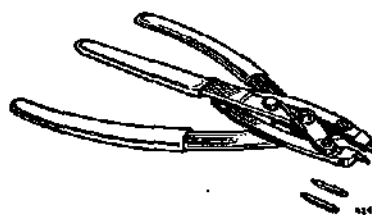

18G 257. Circlip Pliers—Large

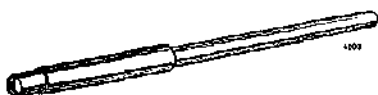

4009

18G 167 D. Valve Seat Cutter Pilot

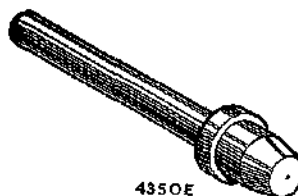

4350E

18G 260. Hub Bearing Outer Race Remover (basic tool)

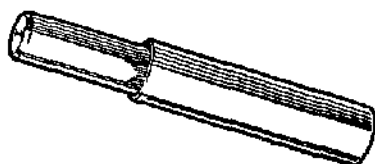

9172

18G 194. Laygear Needle-roller Bearing Replacer



4349E

18G 260 C. Hub Bearing Outer Race Remover Adaptor

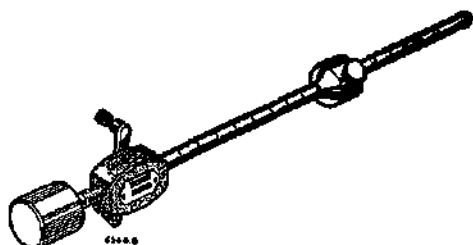

6584B

18G 207. Bearing Preload Gauge

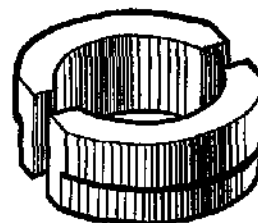

A1423

18G 260 H. Front Hub Drive Flange Bearing Outer Race Remover Adaptor

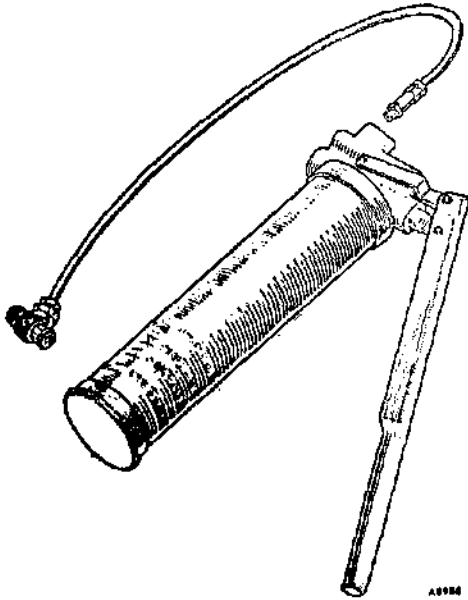

18G 685. The Hydrolastic Hand Pump

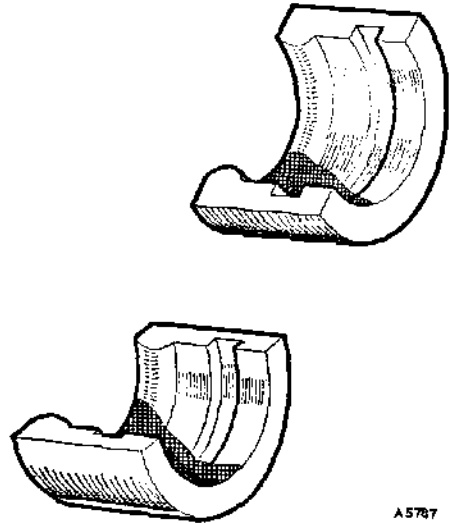

18G 705 B. Bearing Centre Race Remover Adaptor

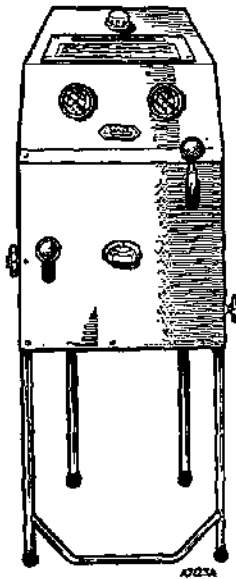

18G 703. The Hydrolastic Suspension Service Unit

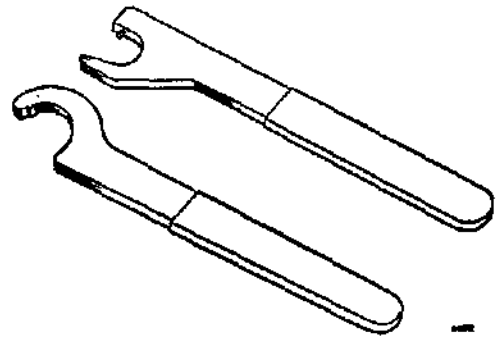

18G 707. Steering Rack Ball Joint Spanners

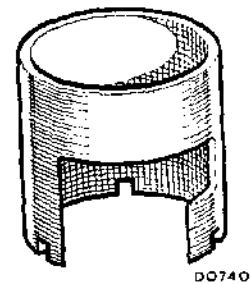

18G 1001. Gauge Locking Ring

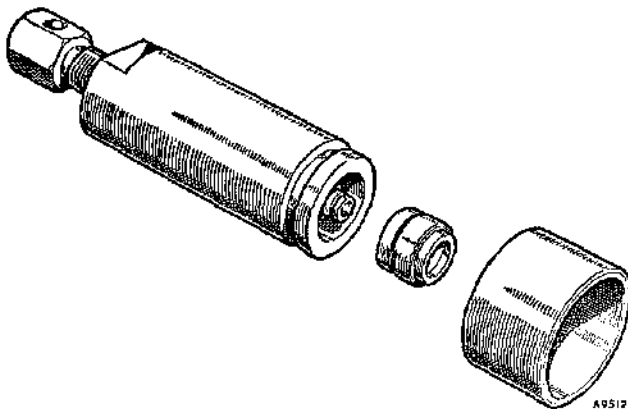

18G 705. Bearing Centre Race Remover (basic tool)

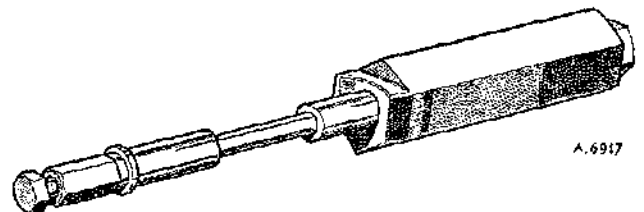

18G 1002. Gudgeon Pin Removing and Replacing Tool

Existing alternative to 18G 1150.

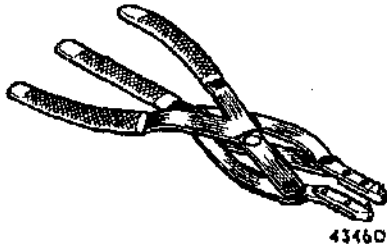

43460

18G 1004. Circlip Pliers

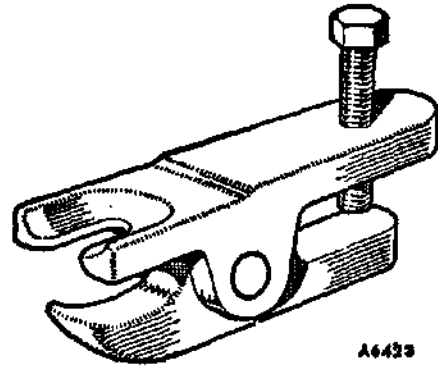

A6433

18G 1063. Steering Arm and Swivel Hub Ball Pin Remover

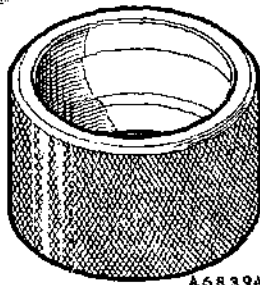

A6839A

●18G 1012. Selection Gauge—Constant Velocity Joint●

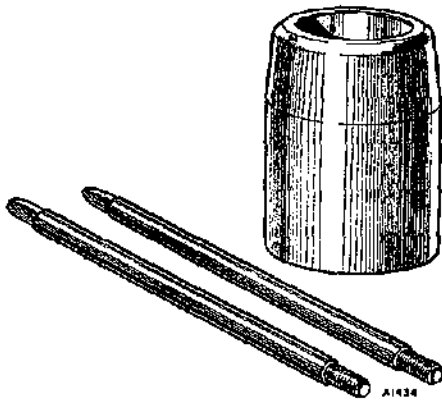

A1434

18G 1043. Crankshaft Primary Gear Oil Seal Protector Sleeve

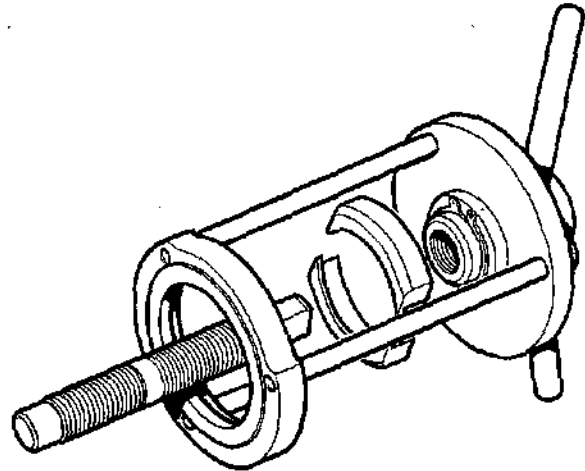

A6722B

●18G 1068 B. Remover and Replacer (basic tool)●

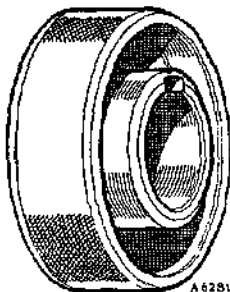

A6281

18G 1044. Engine Front Cover Centralizer

S.18

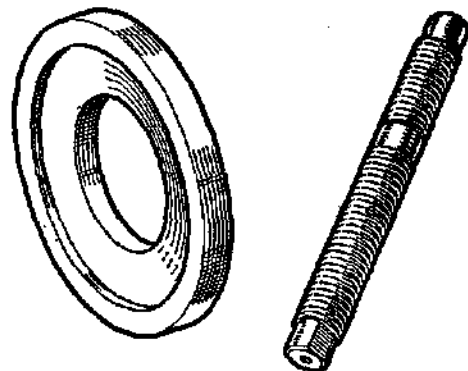

A6726

18G 1068 A. Adaptor Set—Replacer Converter Housing Oil Seal. Use with 18G 1068

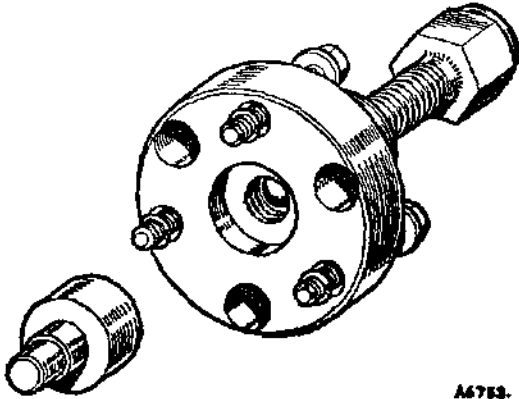

18G 1086. Converter Remover

A6783

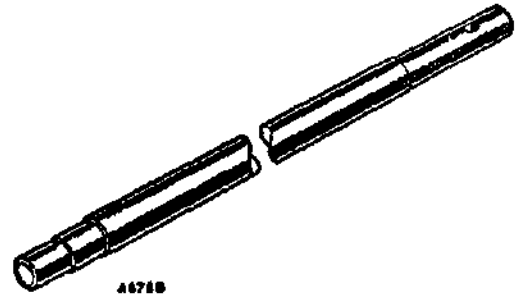

18G 1093. Dummy Shaft—Forward Gear Carrier Assembly

A6788

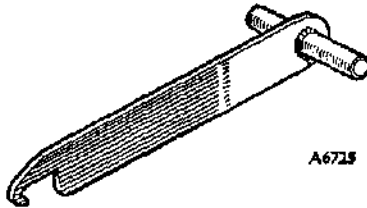

18G 1087. Converter Housing Oil Seal Remover

A6725

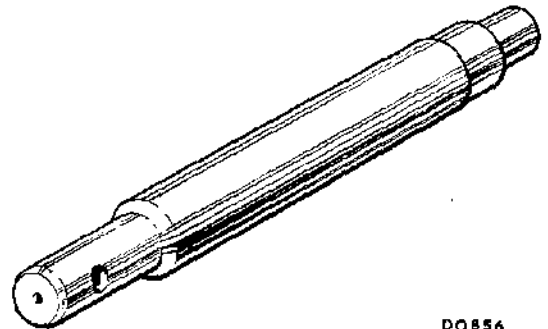

18G 1093 A. Dummy Shaft—Forward Gear Carrier

DO 856

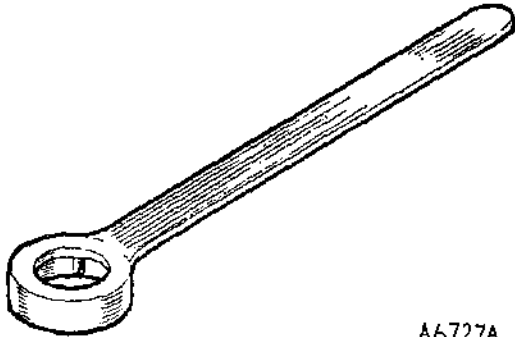

18G 1088. Converter Output Gear Holding Tool

A6727A

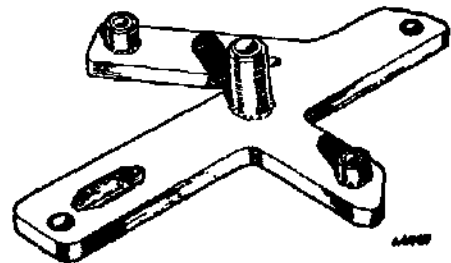

18G 1094. Positioning Fixture—Oil Pump Pipes

A6789

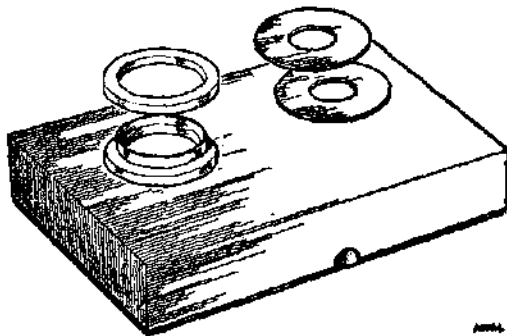

18G 1089. Idler and Input Gear Gauge Kit

A6786

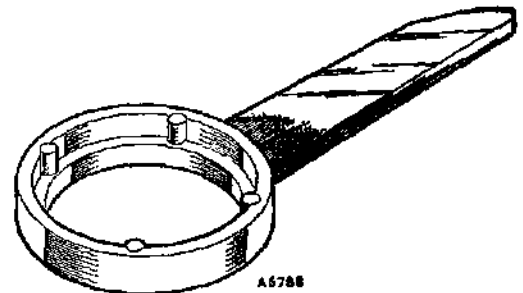

18G 1095. Holder—Top and Reverse Clutch Hub

A6788

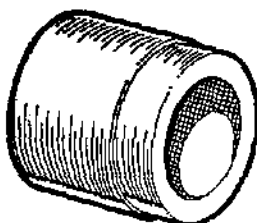

18G 1089 A. Input Gear Gauge Kit Adaptor

D 0309

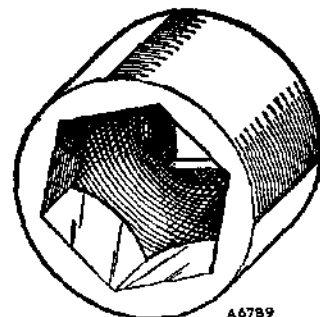

18G 1096. Socket Spanner—Forward Clutch Hub Nut

A6789

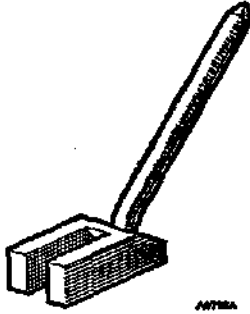

18G 1097. Retainer—Forward Clutch

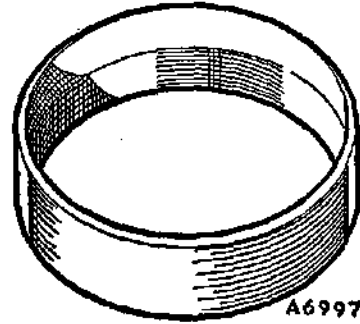

18G 1102. Replacer—Forward Clutch Piston Seal

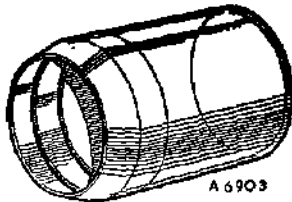

18G 1098. Protector Sleeve—Converter Output Gear Oil Seal

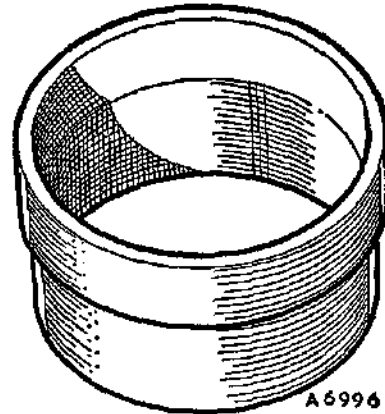

18G 1103. Replacer—Reverse Clutch Piston Seal

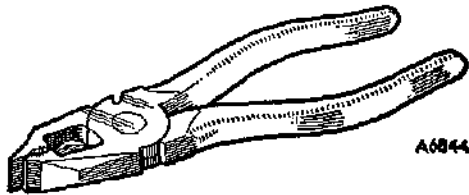

18G 1099. Pliers—Retaining Clip—Drive Shaft Boots

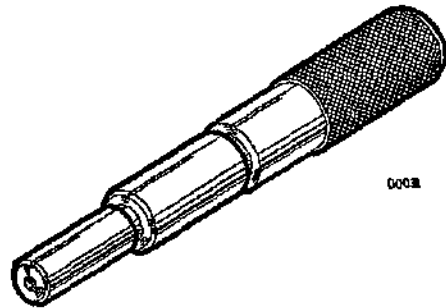

18G 1106. Centralizer—Governor Housing

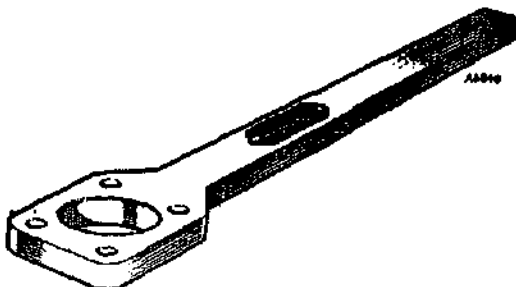

18G 1100. Wrench—Drive Shaft Coupling Flange

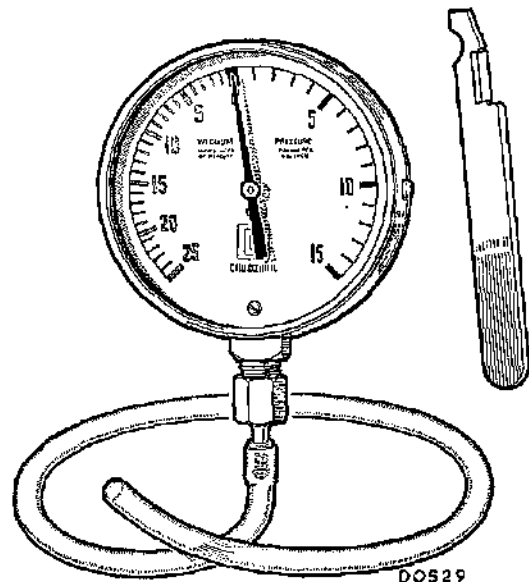

18G 1116. Test Gauge—Mechanical Fuel Pump.

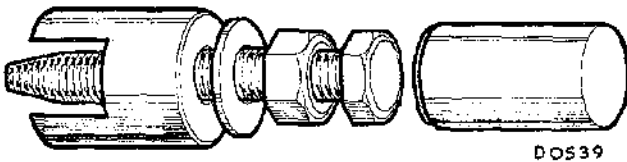

●18G 1119. Mechanical Fuel Pump Oil Seal Retainer—Remover/Replacer ●

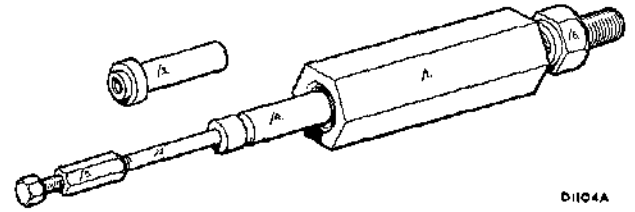

●18G 1150. Gudgeon Pin Remover/Replacer (Basic tool) (18G 1002 existing alternative.) ●

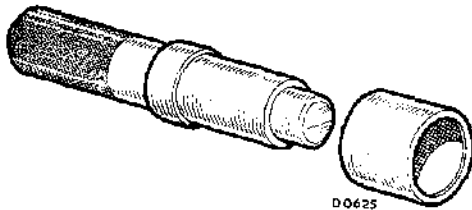

●18G 1126. Idler Gear Bearing Remover/Replacer (Four-speed synchromesh transmission only.) ●

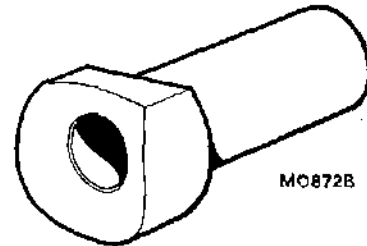

●18G 1150 A. Gudgeon Pin Remover/Replacer Adaptor ●

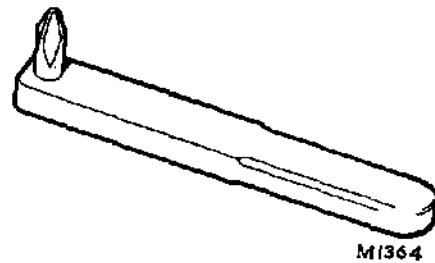

●18G 1188. Door Hinge Screws Remover/Replacer ●

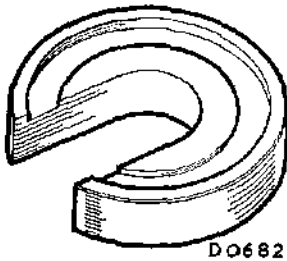

18G 1127. Third Motion Shaft Bearing Remover (Use on four-speed synchromesh transmission.)

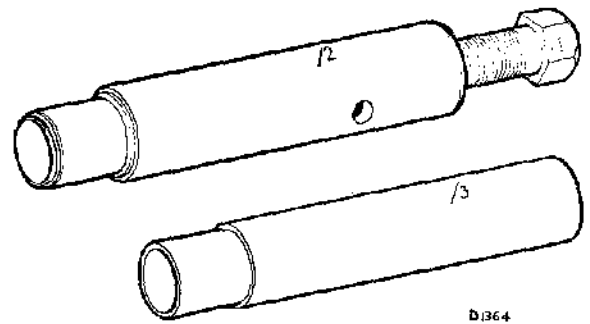

●18G 1191. Steering-column Bush (Upper) Remover/Replacer



SECTION S

SERVICE TOOLS

This Section includes all Service tools for the Mini range of vehicles including the Mini-Cooper and Mini-Cooper 'S'. The tools which are applicable to the Cooper and Cooper 'S' only are shown in brackets after the 'Operation' description

| | <i>Operation</i> | <i>Tool No.</i> | <i>Page No.</i> |
|---------------|--|--|---|
| ENGINE | | | |
| | Camshaft liner reaming | { 18G 123 A 18G 123 AH 18G 123 AJ 18G 123 AN | S.7 S.8 S.8 S.8 |
| | Camshaft liner reaming (Cooper and Cooper 'S') | { 18G 123 A 18G 123 B 18G 123 AN 18G 123 AP 18G 123 AT 18G 123 AQ 18G 123 BA 18G 123 BB 18G 123 BC | S.7 S.8 S.8 S.8 S.8 S.8 S.8 S.8 S.8 |
| | Camshaft liner removing and replacing | { 18G 124 A 18G 124 K | S.8 S.9 |
| | Camshaft liner removing and replacing (Cooper and Cooper 'S') .. | { 18G 124 A 18G 124 B 18G 124 K 18G 124 M | S.8 S.9 S.9 S.9 |
| | Circlip removing and refitting | { 18G 257 18G 1004 | S.10 S.17 |
| | Crankshaft and camshaft gear removing | { 18G 2 18G 98 | S.7 S.7 |
| | Crankshaft primary gear oil seal removing and replacing | { 18G 134 18G 134 BC 18G 1043 18G 1068 | S.9 S.9 S.18 S.18 |
| | Flywheel and clutch removal (coil spring clutch) | { 18G 304 18G 304 M 18G 587 | S.11 S.11 S.15 |
| | Flywheel and clutch removal (diaphragm spring clutch) | { 18G 304 18G 304 N 18G 587 | S.11 S.11 S.15 |
| | Flywheel housing bearing removing and replacing | 18G 617 A | S.16 |

| <i>Operation</i> | <i>Tool No.</i> | <i>Page No.</i> |
|---|---|--|
| Flywheel oil seal replacing | { 18G 134 18G 134 BH | S.9 S.9 |
| Oil pump relief valve seat grinding | 18G 69 | S.7 |
| Piston refitting | 18G 55 A | S.7 |
| Piston refitting (Cooper and Cooper 'S') | { 18G 55 A 18G 1002 | S.7 S.17 |
| Timing cover oil seal replacing | { 18G 134 18G 134 BD | S.9 S.9 |
| Timing cover refitting | { 18G 138 18G 1044 | S.9 S.18 |
| Torque setting nuts and bolts | { 18G 372 18G 536 18G 537 18G 592 | S.11 S.12 S.12 S.15 |
| Valve removing and refitting | 18G 45 | S.7 |
| Valve grinding-in | 18G 29 | S.7 |
| Valve seat cutting | { 18G 27 18G 167 18G 167 A 18G 167 B 18G 167 C 18G 167 D | S.7 S.9 S.9 S.1 S.1 S.1 |
| FUEL SYSTEM | | |
| Fuel tank gauge unit removing and refitting | 18G 1001 | S.17 |
| CLUTCH | | |
| Clutch dismantling and reassembling (coil spring clutch) | { 18G 304 M 18G 571 | S.11 S.12 |
| Clutch dismantling and reassembling (coil spring clutch—Cooper) | { 18G 304 M 18G 684 | S.11 S.16 |
| Clutch dismantling and reassembling (diaphragm spring clutch) | { 18G 304 N 18G 571 | S.11 S.12 |
| Clutch dismantling and reassembling (diaphragm spring clutch—Cooper and Cooper 'S') | { 18G 304 N 18G 684 | S.11 S.16 |

| <i>Operation</i> | <i>Tool No.</i> | <i>Page No.</i> |
|---|--------------------------------------|----------------------|
| TRANSMISSION UNIT | | |
| Change speed shaft oil seal replacement | 18G 573 | S.13 |
| Circlip removing and refitting | { 18G 257 18G 1004 | S.10 S.18 |
| Final drive gear removing and refitting | { 18G 586 18G 587 | S.15 S.15 |
| First and third motion shaft bearing replacement | 18G 579 | S.14 |
| First motion shaft and bearing removing | { 18G 284 18G 284 B | S.11 S.11 |
| First motion shaft bearing circlip—checking for correct thickness circlip | 18G 569 | S.12 |
| First motion shaft needle-roller bearing removing and replacing | { 18G 581 18G 581 B 18G 589 | S.14 S.14 S.15 |
| Idler gear bearing removing and replacing | { 18G 581 18G 582 | S.14 S.14 |
| Laygear needle-roller bearing replacement | 18G 194 | S.10 |
| Layshaft reassembly | 18G 471 | S.12 |
| Synchromesh unit assembling | 18G 572 | S.13 |
| Third motion shaft bearing removing (3-speed synchromesh) | 18G 613 | S.15 |
| Third motion shaft bearing removing (4-speed synchromesh) | 18G 1127 | S.20 |
| Torque setting nuts and bolts | { 18G 372 18G 536 18G 537 | S.11 S.12 S.12 |
| DIFFERENTIAL UNIT | | |
| Differential bearing removing and replacement | { 18G 2 18G 578 | S.7 S.4 |
| Drive shaft coupling flange removing and refitting | 18G 669 | S.16 |
| Torque setting nuts and bolts | { 18G 372 18G 537 | S.11 S.12 |
| AUTOMATIC TRANSMISSION | | |
| Auxiliary pump and governor assembly removing and refitting | { 18G 1094 18G 1097 18G 1106 | S.19 S.20 S.20 |
| Converter housing oil seal replacing | { 18G 1068 18G 1068 A 18G 1087 | S.18 S.18 S.19 |

| <i>Operation</i> | <i>Tool No.</i> | <i>Page No.</i> |
|---|--|------------------------------|
| Converter housing removing and refitting | { 18G 1088 18G 1098 | S.19 S.20 |
| Converter removing and refitting | { 18G 587 18G 1086 | S.15 S.19 |
| Differential drive shaft coupling removing | 18G 1100 | S.20 |
| Forward clutch dismantling and reassembling | 18G 1102 | S.20 |
| Forward clutch hub nut removing and refitting | { 18G 1095 18G 1096 | S.19 S.19 |
| Gear carrier assembly dismantling and reassembling (early-type units) | 18G 1093 | S.19 |
| Gear carrier assembly dismantling and reassembling (later-type units) | 18G 1093 A | S.19 |
| Idler and input gears—checking adjustment | { 18G 1089 18G 1089 A | S.19 S.19 |
| Pressure and stall checks | { 18G 677 C 18G 677 Z | S.16 S.16 |
| Converter output gear oil seal removing and replacing | { 18G 134 18G 134 CN | S.9 S.9 |
| Top and reverse clutch dismantling and reassembling | 18G 1103 | S.20 |
| Top and reverse clutch hub removing and refitting | { 18G 1095 18G 1096 | S.19 S.19 |
| Torque setting | { 18G 372 18G 537 18G 592 | S.11 S.12 S.15 |
| DRIVE SHAFTS | | |
| Constant velocity joint—checking ball cage and inner race | { 18G 1012 18G 1099 | S.18 S.20 |
| Drive shaft removing and refitting | { 18G 1063 18G 304 or 18G 304 Z 18G 304 F | S.18 S.11 S.11 S.11 |
| Torque setting | 18G 372 | S.11 |
| REAR SUSPENSION | | |
| Displacer unit or strut removing and refitting | 18G 703 | S.17 |
| Hub bearing outer race removing | { 18G 260 18G 260 C | S.10 S.10 |
| Hub removing | { 18G 304 or 18G 304 Z 18G 304 F | S.11 S.11 S.11 |

| <i>Operation</i> | <i>Tool No.</i> | <i>Page No.</i> |
|---|-----------------------------------|-----------------|
| Hydrostatic suspension—checking pressure | [18G 685 18G 703 | S.17 |
| | | S.17 |
| Hydrostatic suspension—depressurizing, evacuating, and pressurizing | 18G 703 | S.17 |
| Radius arm bush reaming | [18G 588 18G 588 A | S.15 |
| | | S.15 |
| Radius arm bushes removing and replacing | [18G 583 18G 584 | S.14 |
| | | S.15 |
| Radius arm needle bearing removing and replacing | [18G 583 18G 583 B 18G 620 | S.14 |
| | | S.15 |
| | | S.16 |
| Radius arms (Hydrostatic suspension) removing and refitting .. | 18G 703 | S.17 |
| Sub-frame (Hydrostatic models) removing and refitting | 18G 703 | S.17 |

STEERING GEAR

| | | |
|--|-----------------------------------|------|
| Steering rack dismantling and reassembling | [18G 207 18G 207 A 18G 707 | S.10 |
| | | S.10 |
| | | S.17 |
| Steering rack tie-rod ball joint removal | 18G 1063 | S.18 |
| Torque setting | [18G 372 18G 537 | S.11 |
| | | S.12 |

FRONT SUSPENSION

| | | |
|--|---|------|
| Displacer unit or strut removing and refitting | 18G 703 | S.17 |
| Hydrostatic suspension—checking pressure | [18G 685 18G 703 | S.17 |
| | | S.17 |
| Hydrostatic suspension—depressurizing, evacuating, and pressurizing | 18G 703 | S.17 |
| Lower arm removal | 18G 1063 | S.18 |
| Spring unit or strut (Rubber suspension models) removing and refitting | [18G 574 B 18G 1063 | S.13 |
| | | S.18 |
| Swivel hub joint removing and replacing | [18G 587 18G 1063 | S.15 |
| | | S.18 |
| Swivel hub dismantling, fitting bearings, and reassembling | [18G 304 or 18G 304 Z 18G 304 F 18G 575 18G 260 18G 260 H | S.11 |
| | | S.11 |
| | | S.11 |
| | | S.14 |
| | | S.10 |
| | | S.10 |

| <i>Operation</i> | <i>Tool No.</i> | <i>Page No.</i> |
|---|-----------------|-----------------|
| Swivel hub driving flange removing (without dismantling the swivel hub) | 18G 284 | S.11 |
| | 18G 304 or | S.11 |
| | 18G 304 Z | S.11 |
| | 18G 304 F | S.11 |
| | 18G 304 P | S.11 |
| Swivel hub outer oil seal replacing | 18G 284 | S.11 |
| | 18G 304 or | S.11 |
| | 18G 304 Z | S.11 |
| | 18G 304 F | S.11 |
| | 18G 304 P | S.11 |
| | 18G 705 | S.17 |
| 18G 705 B | S.17 | |
| Swivel hub removing and refitting | 18G 1063 | S.18 |
| Torque setting nuts and bolts | 18G 372 | S.11 |
| | 18G 537 | S.12 |
| Upper arm (Hydrolastic suspension models) removing, dismantling, and reassembling | 18G 581 | S.14 |
| | 18G 582 | S.14 |
| | 18G 582 A | S.14 |
| | 18G 703 | S.17 |
| | 18G 1063 | S.18 |
| Upper arm (rubber suspension models) removing, dismantling, and reassembling | 18G 574 B | S.13 |
| | 18G 581 | S.14 |
| | 18G 582 | S.14 |
| | 18G 582 A | S.14 |
| | 18G 1063 | S.18 |
| BRAKING SYSTEM | | |
| Brake adjusting | 18G 619 A | S.16 |
| Disc brake piston seal replacing (Cooper and Cooper 'S') | 18G 672 | S.16 |
| BODY | | |
| Body alignment checking | 18G 560 | S.13 |
| | 18G 560 A | S.13 |
| | 18G 560 B | S.13 |
| Body alignment checking (not illustrated) | Churchill 7/700 | |
| Windscreen and back-light glass refitting | 18G 468 | S.12 |
| | 18G 468 A | S.12 |

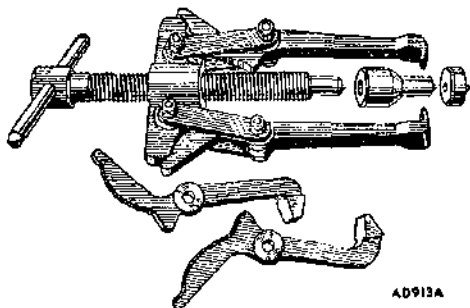

18G 2. Crankshaft Gear and Pulley Remover

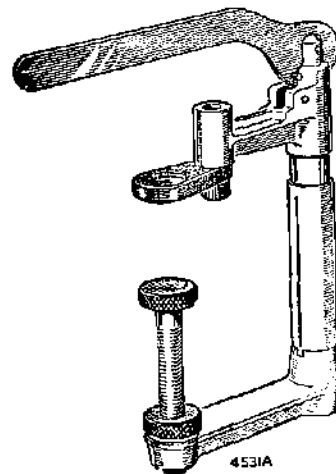

18G 45. Valve Spring Compressor

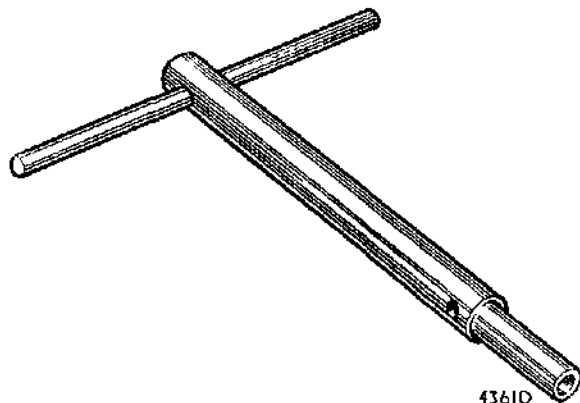

18G 27. Valve Seat Cutter Handle

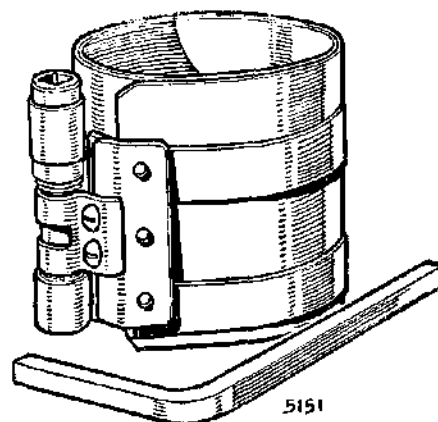

18G 55 A. Piston Ring Compressor

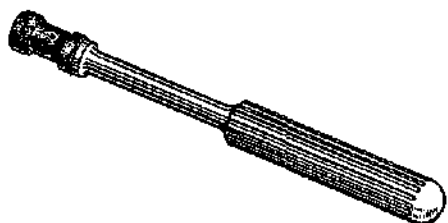

18G 29. Valve Suction Grinder

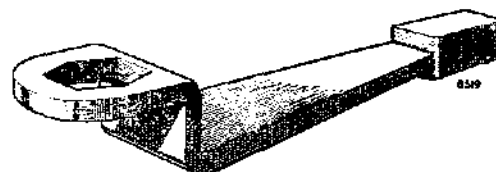

18G 98. Shock Spanner

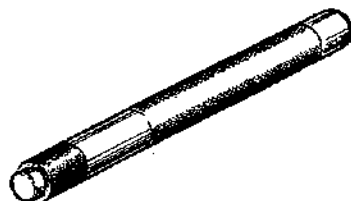

18G 69. Oil Pump Release Valve Grinding-in Tool

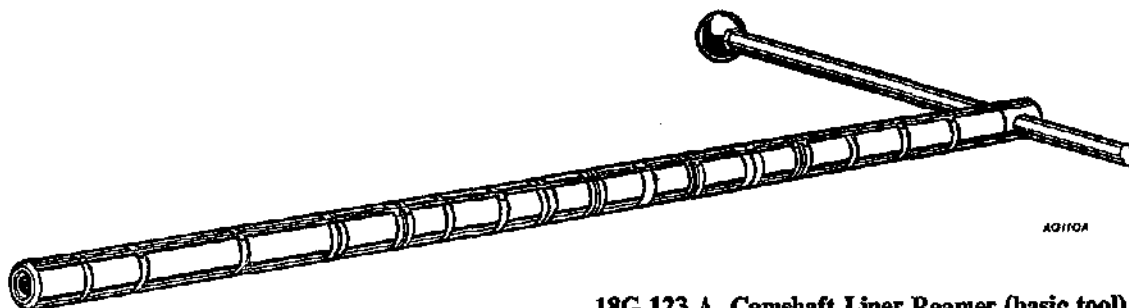

18G 123 A. Camshaft Liner Reamer (basic tool)



A1039

18G 123 AH. Camshaft Liner Reamer Pilot—Centre

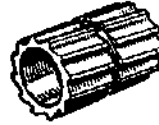

A4964

18G 123 B. Camshaft Liner Reamer Cutter

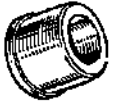

A1039

18G 123 AJ. Camshaft Liner Reamer Pilot—Rear



A4963

18G 123 BA. Camshaft Liner Reamer Pilot—Rear

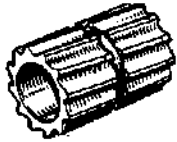

A1039

18G 123 AN. Camshaft Liner Reamer Cutter—Front



A4963

18G 123 BB. Camshaft Liner Reamer Pilot—Rear

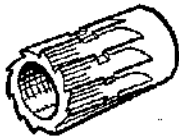

4946A

18G 123 AP. Camshaft Liner Reamer Cutter—Rear



A4963

18G 123 BC. Camshaft Liner Reamer Pilot—Front

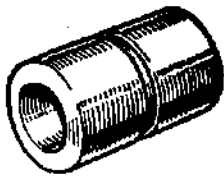

A4963

18G 123 AQ. Camshaft Liner Reamer Pilot—Front



A4963

18G 123 AT. Camshaft Liner Reamer Pilot—Centre

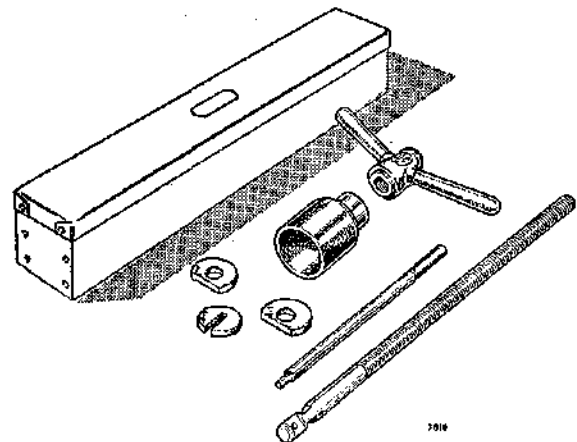

18G 124 A

18G 124 A. Camshaft Liner Remover and Replacer (basic tool)

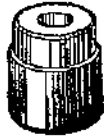

A4933

18G 124 B Camshaft Liner Remover Adaptor



A1429A

18G 134 BH. Flywheel and Front Hub Oil Seal Replacer Adaptor

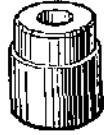

A4933

18G 124 K. Camshaft Liner Remover Adaptor

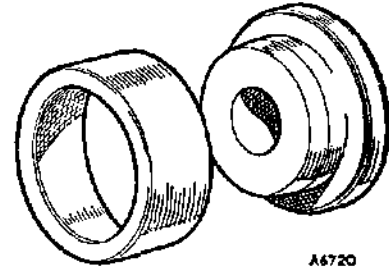

A6720

18G 134 CN. Replacer Oil Seal Stator Carrier



A4933

18G 124 M. Camshaft Liner Remover Adaptor



829XX

18G 134. Bearing and Oil Seal Replacer (basic tool)

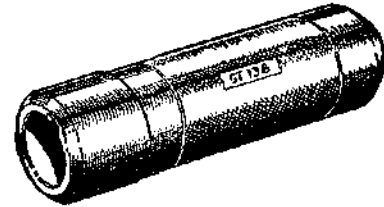

8138

18G 138. Crankshaft Gear and Pulley Replacer

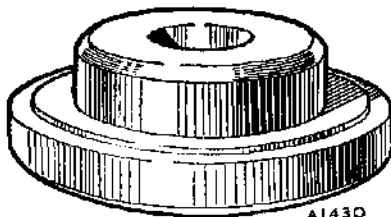

A1430

18G 134 BC. Crankshaft Primary Gear Oil Seal Replacer Adaptor

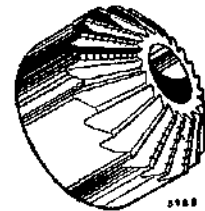

5188

18G 167. Valve Seat Finishing Cutter

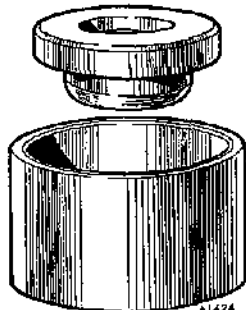

A1424

18G 134 BD. Timing Case Oil Seal Replacer Adaptor

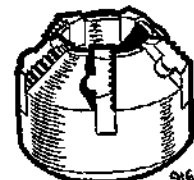

9165A

18G 167 A. Valve Seat Glaze Breaker

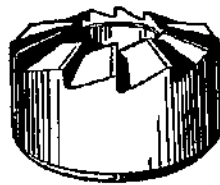

9021B

18G 167 B. Valve Seat Narrowing Cutter—Top

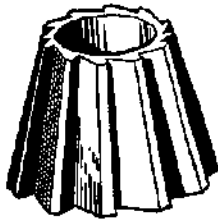

9021A

18G 167 C. Valve Seat Narrowing Cutter—Bottom



18G 167 D. Valve Seat Cutter Pilot

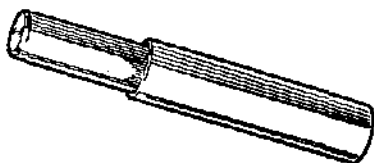

9172

18G 194. Laygear Needle-roller Bearing Replacer

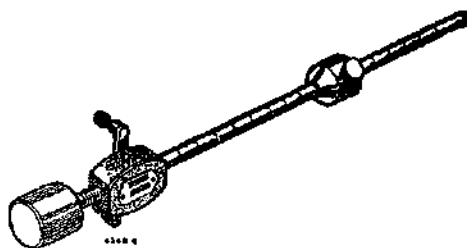

18G 207. Bearing Preload Gauge

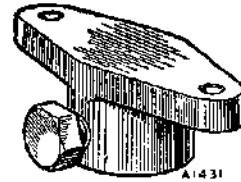

A1431

18G 207 A. Steering Rack Pinion Preload Adaptor

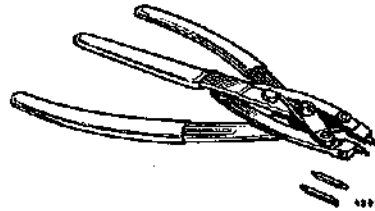

18G 257. Circlip Pliers—Large

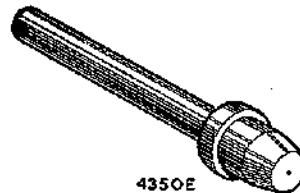

4350E

18G 260. Hub Bearing Outer Race Remover (basic tool)

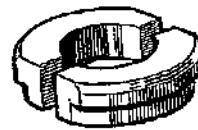

4349E

18G 260 C. Hub Bearing Outer Race Remover Adaptor

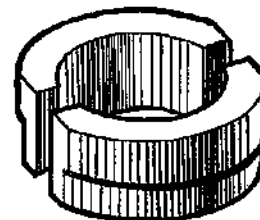

A1423

18G 260 H. Front Hub Drive Flange Bearing Outer Race Remover Adaptor

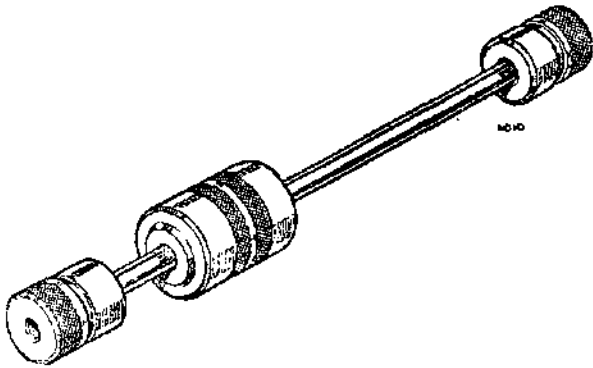

18G 284. Impulse Extractor (basic tool)

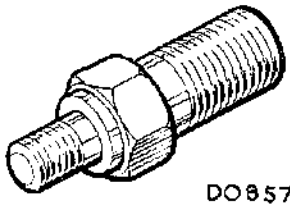

18G 284 AJ. Planetary Gear Spindles Remover Adaptor

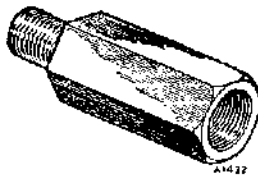

18G 284 B. First Motion Shaft Remover Adaptor

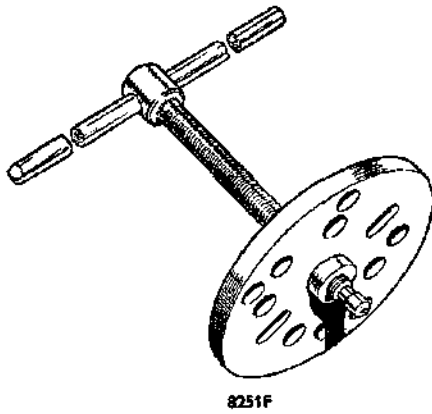

18G 304. Front and Rear Hub Remover (basic tool)



18G 304 F. Front and Rear Hub Remover Bolt Adaptor

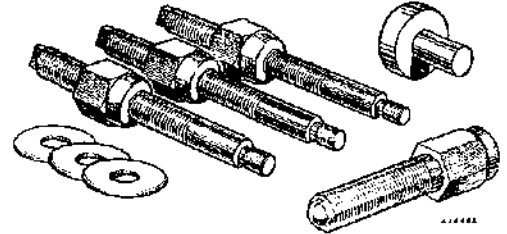

18G 304 M. Flywheel and Clutch Remover Adaptor

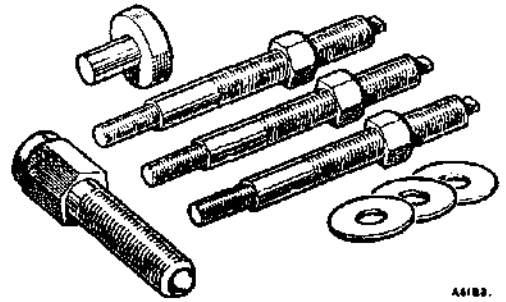

18G 304 N. Flywheel and Clutch Remover Adaptors

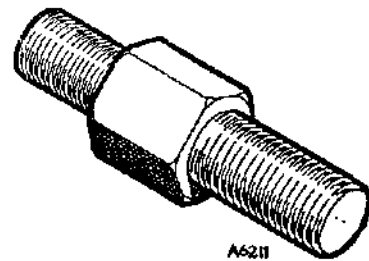

18G 304 P. Drive Flange Remover Adaptor

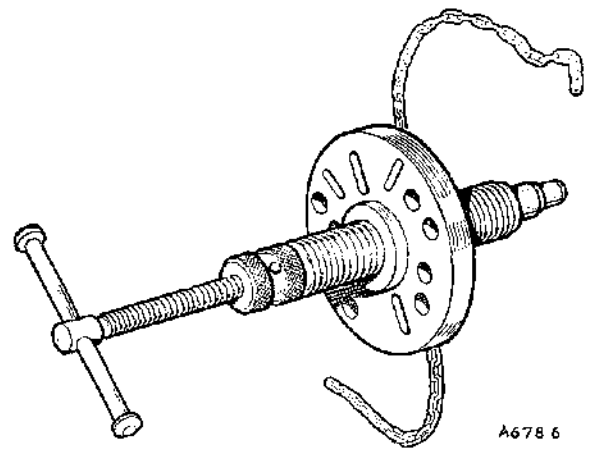

18G 304 Z. Hub Remover—Hydraulic (basic tool)

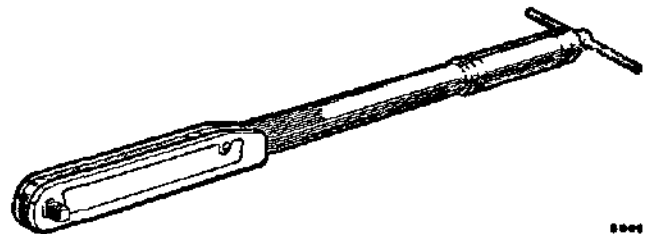

18G 372. Torque Wrench—30 to 140 lb. ft. (4 to 20 kg.m.)

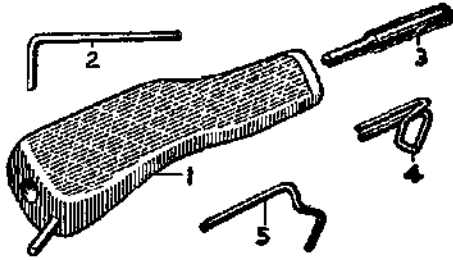

AD994

18G 468. Rubber Moulding Glazing Tool

The tool comprises:

- 1. Handle.
- 2. Key.
- 3. Post.
- 4. Eye.
- 5. Hook.

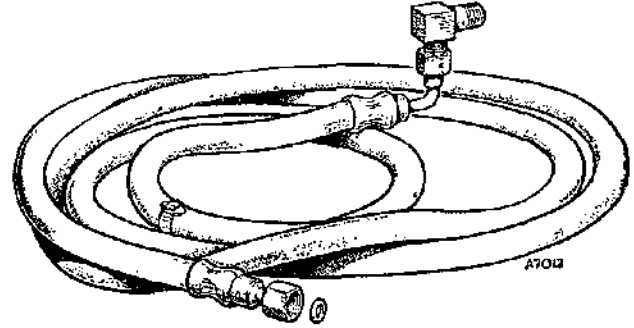

18G 502 K. Pressure Hose (8 ft.) with Adaptor

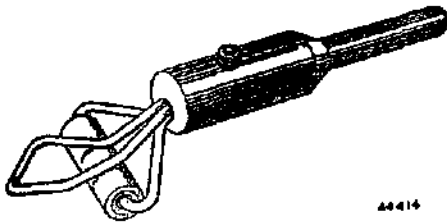

44414

18G 468 A. Rubber Moulding Glazing Tool Adaptor

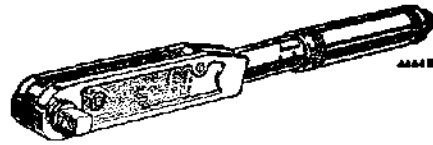

44418

18G 536. Torque Wrench—20 to 100 lb. in. (2 to 8 lb. ft.)
(300 to 1200 gm.m.)

18G 537. Torque Wrench—10 to 50 lb. ft. (2 to 7 kg. m.)

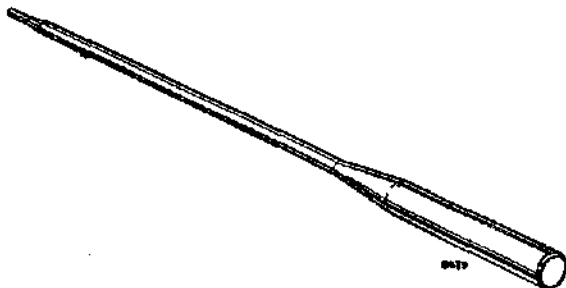

6477

18G 471. Dummy Layshaft

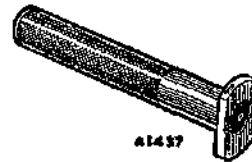

41437

18G 569. First Motion Shaft Bearing Circlip Gauge

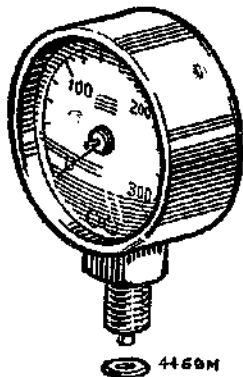

4460M

18G 502 A. Hydraulic Pressure Gauge
S.12

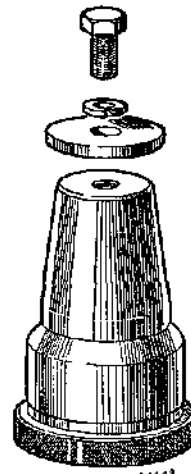

41443

18G 571. Clutch Centralizer

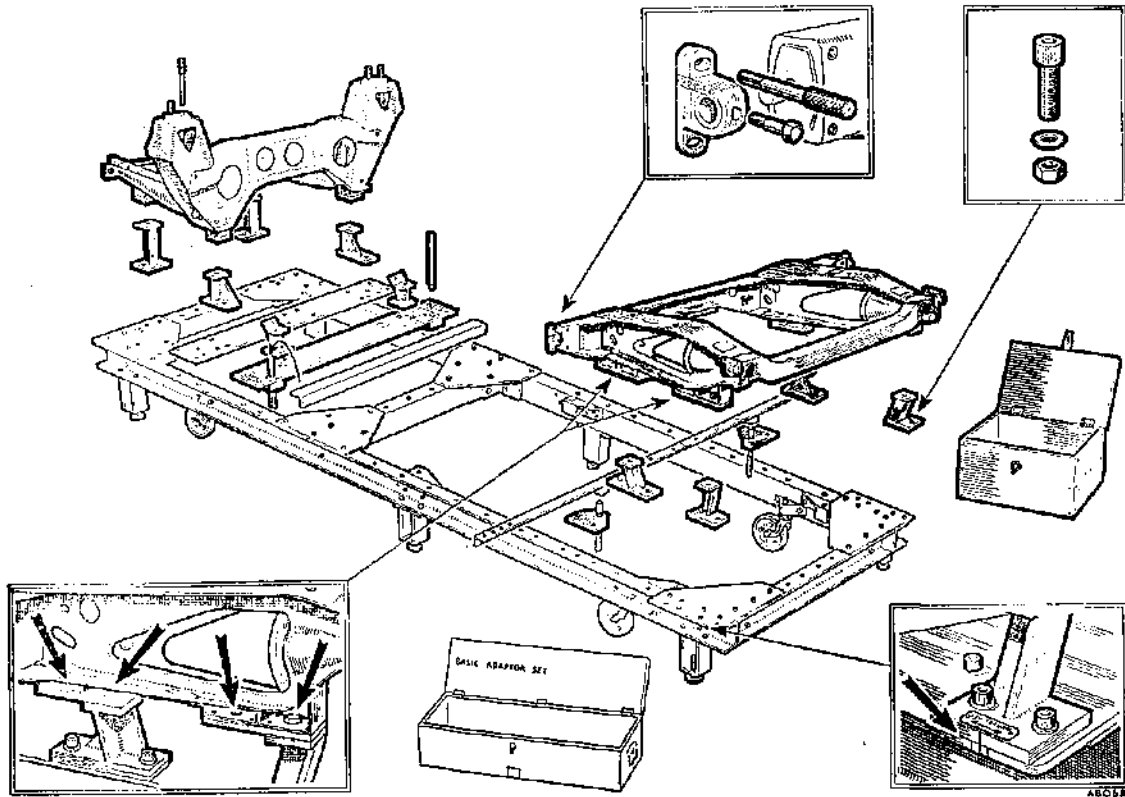

18G 560 E. Body Checking Jig Adaptor Set

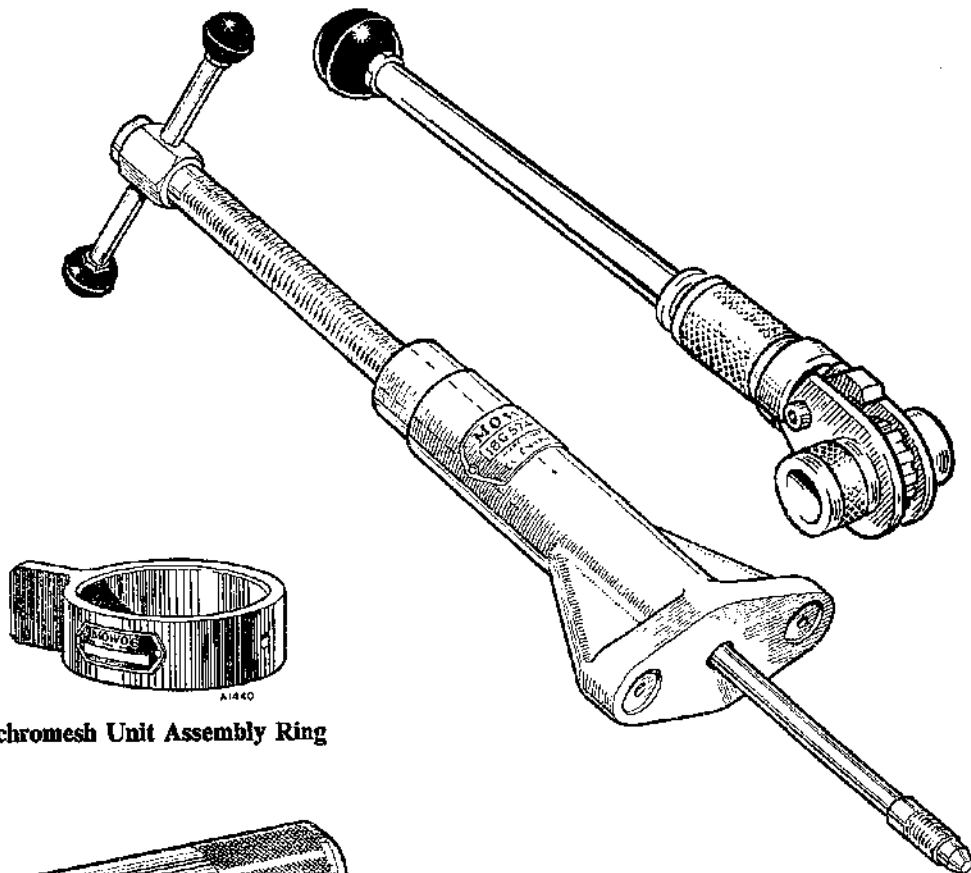

18G 572. Synchronmesh Unit Assembly Ring

18G 574 B. Suspension Rubber Spring Compressor

18G 573. Change Speed Shaft Oil Seal Replacer

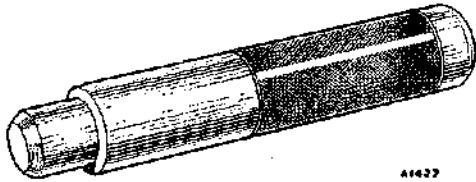

A1427

18G 575. Front Hub Drive Flange Remover

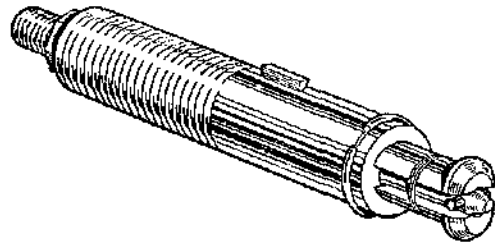

A4464

18G 581 B. First Motion Shaft Spigot Bearing Remover Adaptor

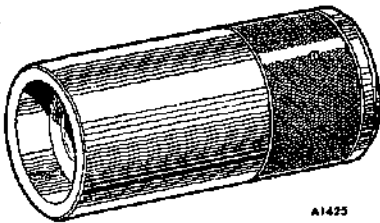

A1425

18G 578. Differential Bearing Replacer

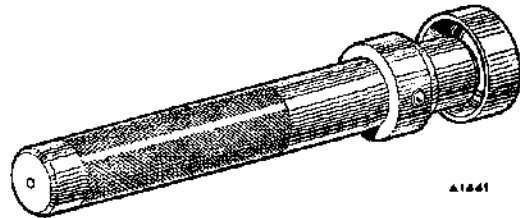

A1441

18G 582. Front Suspension and Idler Gear Bearing Replacer

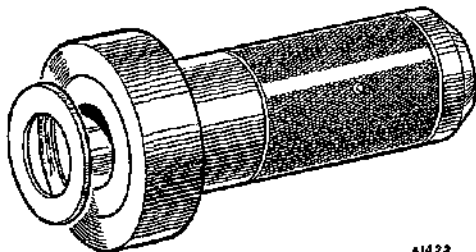

A1422

18G 579. First and Third Motion Shaft Bearing Replacer

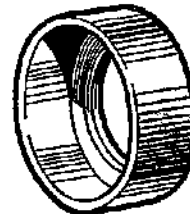

A1439

18G 582 A. Front Suspension and Idler Gear Needle Bearing Replacer Adaptor

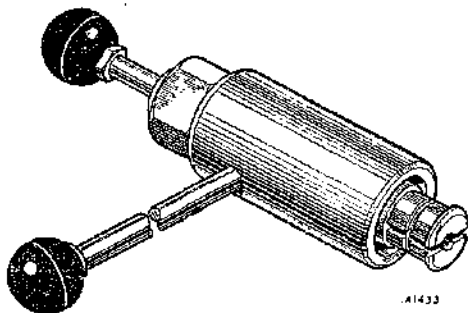

A1433

18G 581. Front Suspension and Idler Gear Needle-bearing Remover

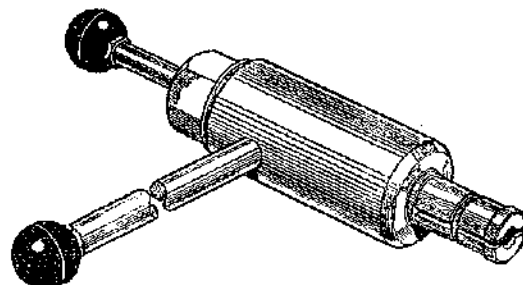

A1430

18G 583. Rear Radius Arm Bush Remover

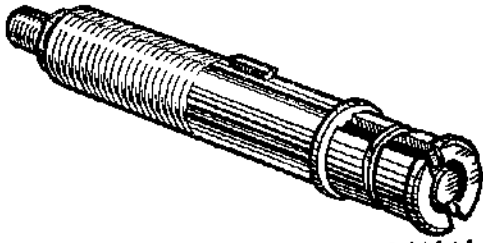

A4464A

18G 583 B. Rear Radius Arm Needle Bearing Remover Adaptor

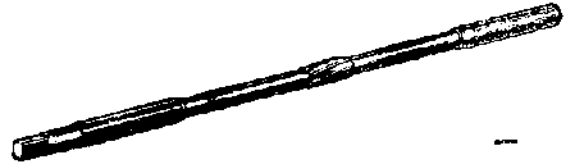

18G 588. Rear Radius Arm Bush Reamer

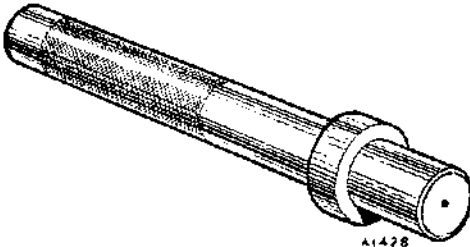

A1428

18G 584. Rear Radius Arm Bush Replacer

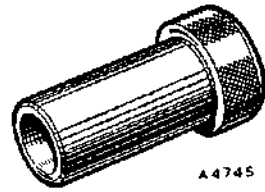

A4745

18G 588 A. Reamer Guide Bush

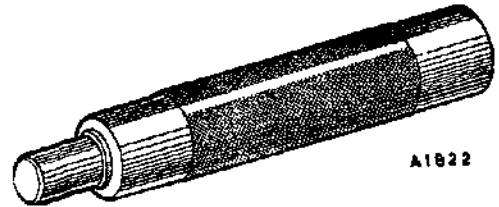

A1822

18G 589. First Motion Shaft Spigot Bearing Replacer

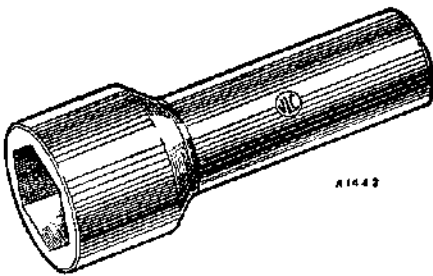

A1442

18G 586. Final Drive Gear Nut Spanner

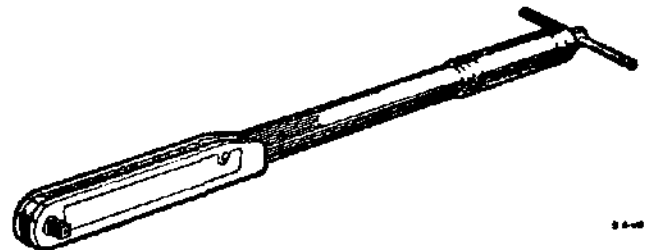

18G 592. Torque Wrench—50 to 225 lb. ft. (5 to 30 kg. m.)

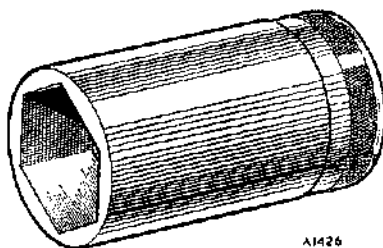

A1426

18G 587. Swivel Hub Ball Pin Nut Spanner
MINI. Issue 2. 16495



A4725

18G 613. Third Motion Shaft Bearing Remover

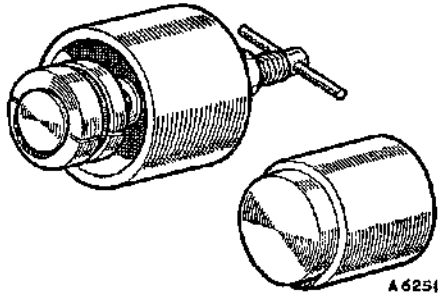

A 6254

18G 617 A. Flywheel Housing Bearing (First Motion Shaft) Outer Race Remover/Replacer

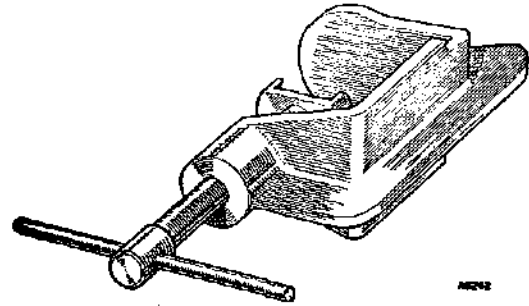

ME72

18G 672. Disc Brake Piston Seal Replacer

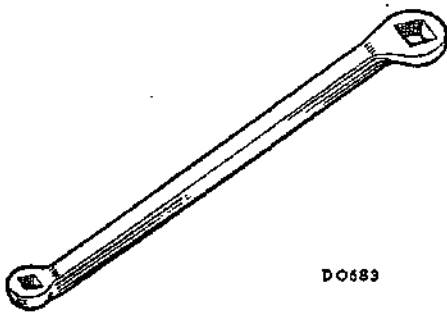

D 0689

18G 619 A. Brake Adjusting Spanner

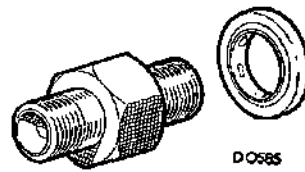

D 0685

18G 677 C. Pressure Test Equipment Adaptor

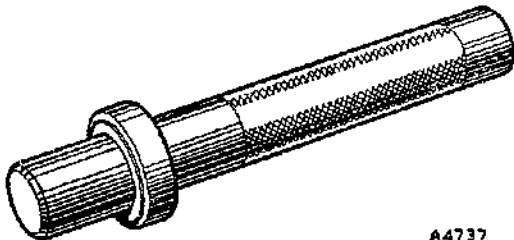

A4737

18G 620. Rear Radius Arm Needle Bearing Replacer

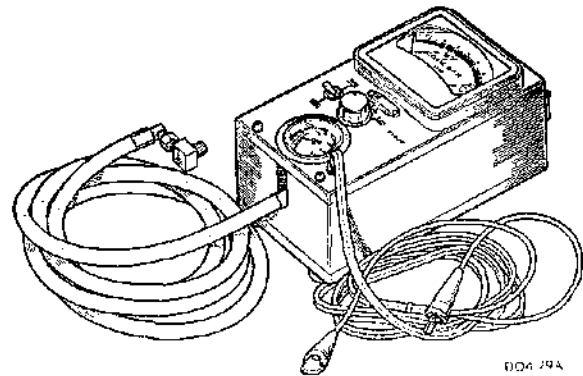

D 06 29A

18G 677 Z. Pressure Test and Tachometer Equipment

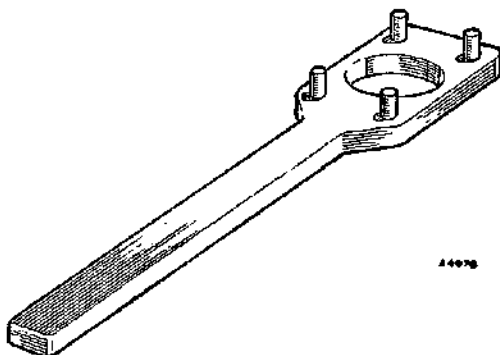

A 4978

18G 669. Drive Shaft Coupling Flange Wrench

S.16

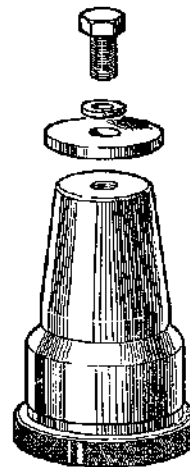

A1443

18G 684. Clutch Centralizer

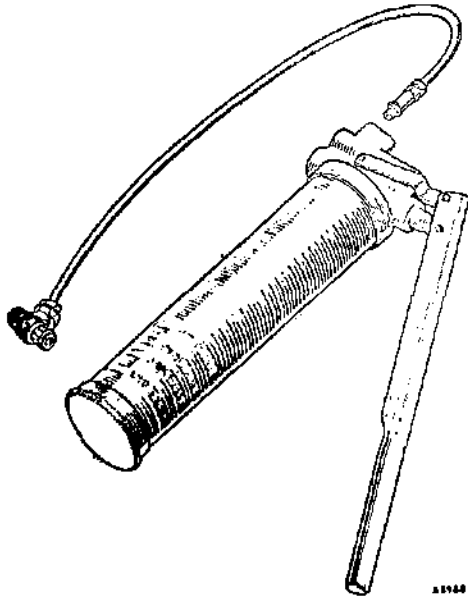

18G 685. The Hydrolastic Hand Pump

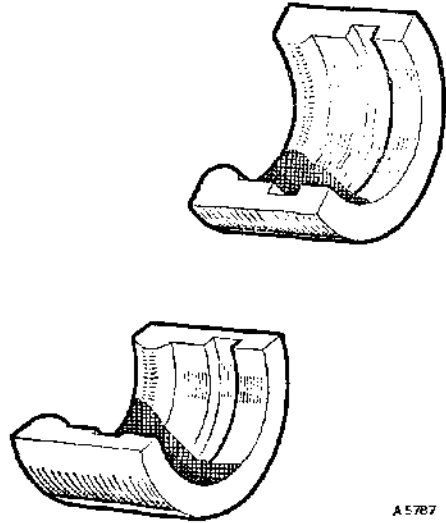

18G 705 B. Bearing Centre Race Remover Adaptor

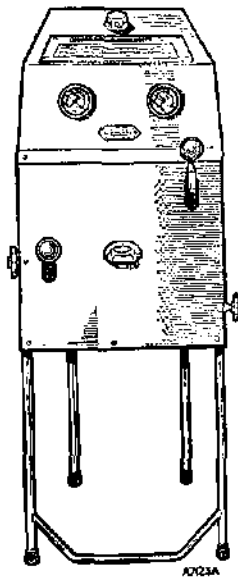

18G 703. The Hydrolastic Suspension Service Unit

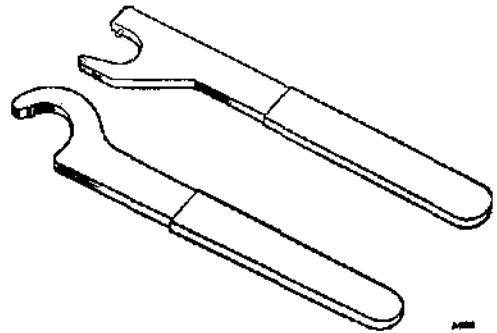

18G 707. Steering Rack Ball Joint Spanners

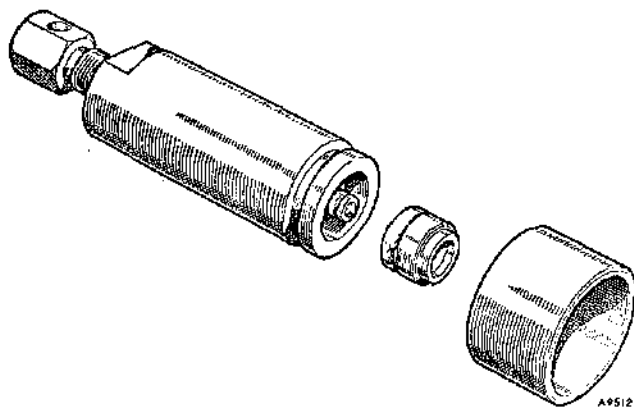

18G 705. Bearing Centre Race Remover (basic tool)

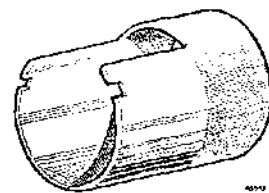

18G 1001. Gauge Locking Ring

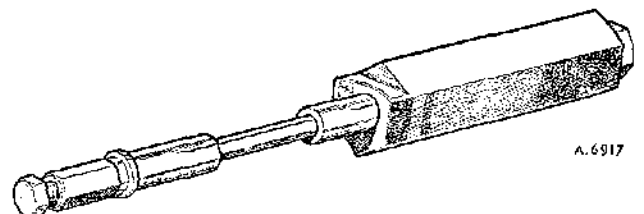

18G 1002. Gudgeon pin removing and replacing tool

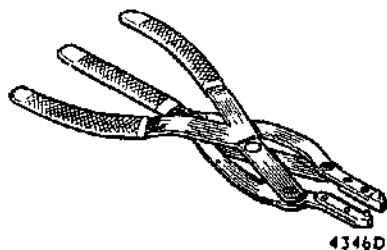

4346D

18G 1004. Circlip Pliers

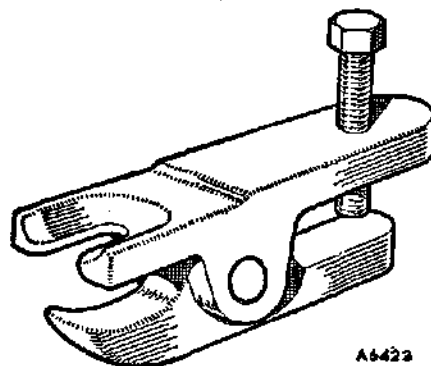

A6422

18G 1063. Steering Arm and Swivel Hub Ball Pin Remover

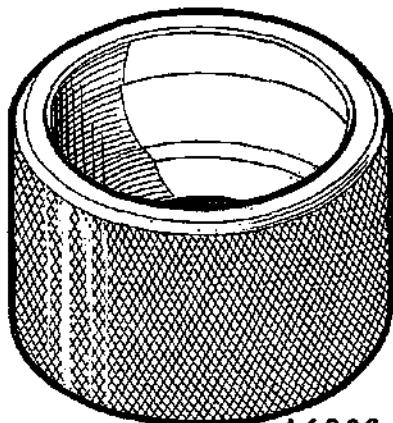

A6839

18G 1012. Selection Gauge—Constant Velocity Joint

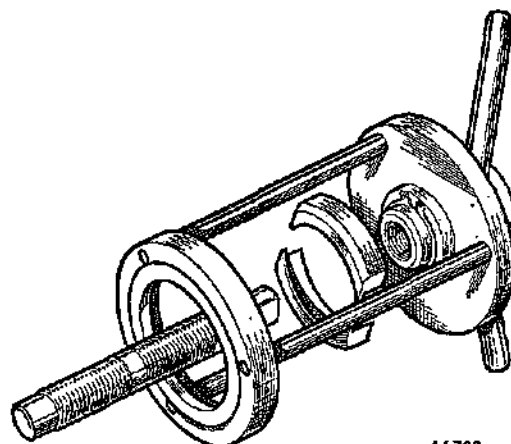

A6722

18G 1068. Remover and Replacer (basic tool)

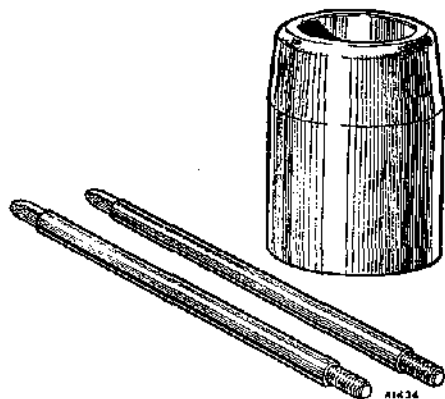

A1434

18G 1043. Crankshaft Primary Gear Oil Seal Protector Sleeve

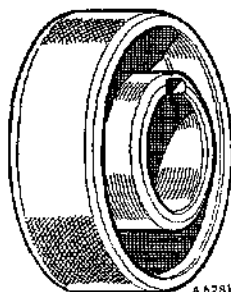

A6281

18G 1044. Engine Front Cover Centralizer
S.18

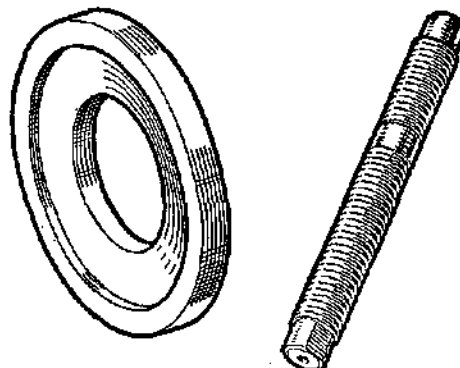

A6726

18G 1068 A. Adaptor Set—Replacer Converter Housing Oil Seal. Use with 18G 1068

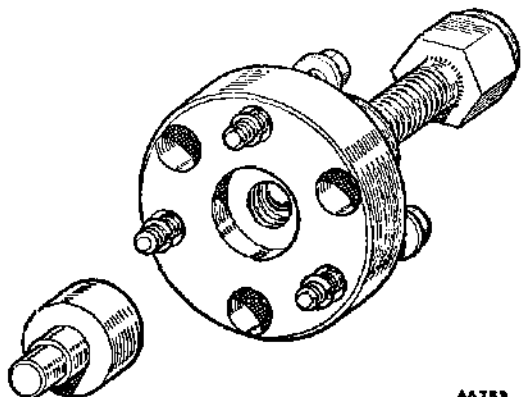

18G 1086. Converter Remover

A6783.

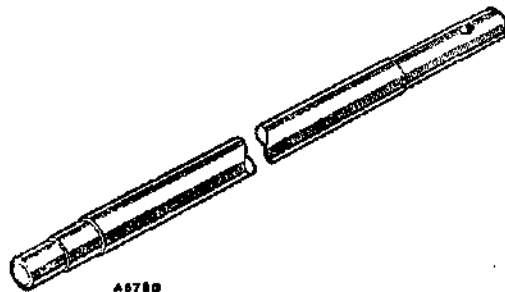

18G 1093. Dummy Shaft—Forward Gear Carrier Assembly

A6780

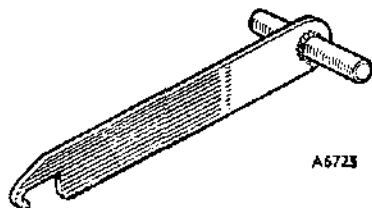

18G 1087. Converter Housing Oil Seal Remover

A6723

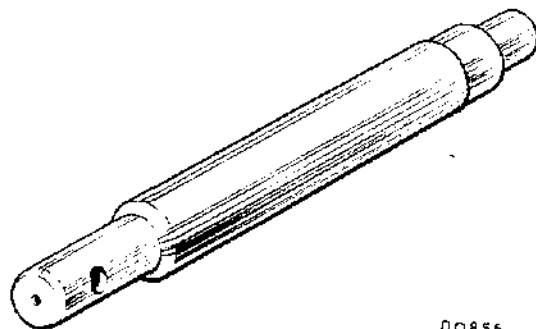

18G 1093 A. Dummy Shaft—Forward Gear Carrier

D0856

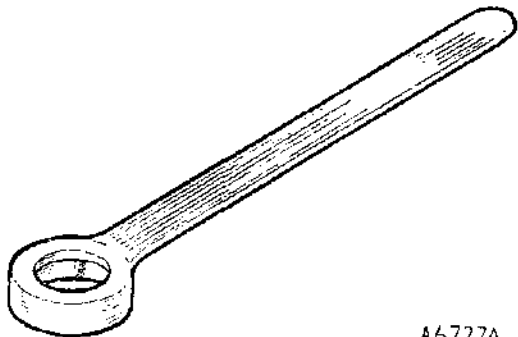

18G 1088. Converter Output Gear Holding Tool

A6727A

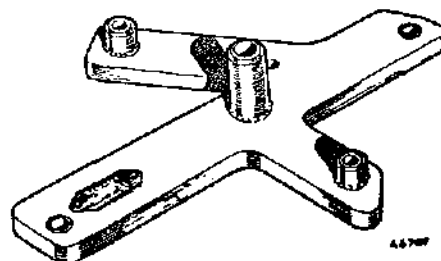

18G 1094. Positioning Fixture—Oil Pump Pipes

A6787

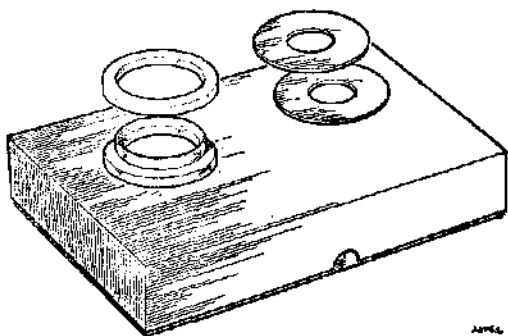

18G 1089. Idler and Input Gear Gauge Kit

A6764

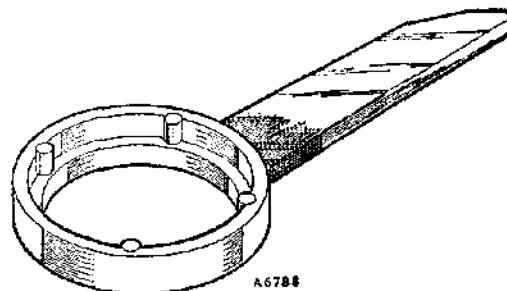

18G 1095. Holder—Top and Reverse Clutch Hub

A6788

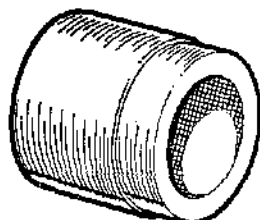

18G 1089 A. Input Gear Gauge Kit Adaptor

D 0309

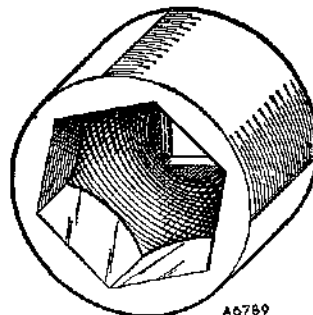

18G 1096. Socket Spanner—Forward Clutch Hub Nut

A6789

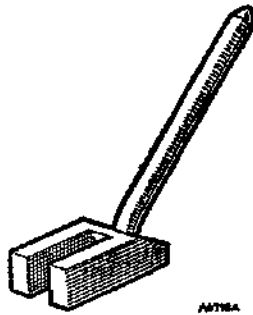

18G 1097. Retainer—Forward Clutch

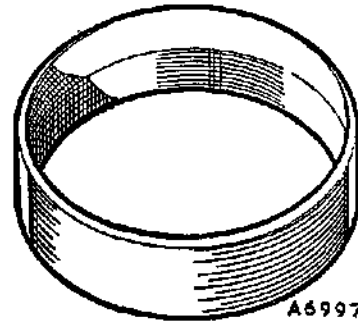

18G 1102. Replacer—Forward Clutch Piston Seal

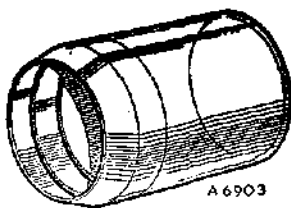

18G 1098. Protector Sleeve—Converter Output Gear Oil Seal

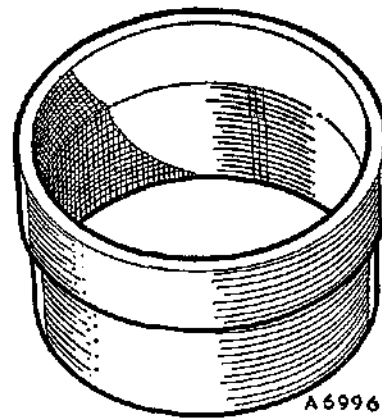

18G 1103. Replacer—Reverse Clutch Piston Seal

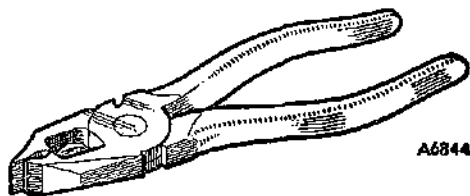

18G 1099. Pliers—Retaining Clip—Drive Shaft Boots

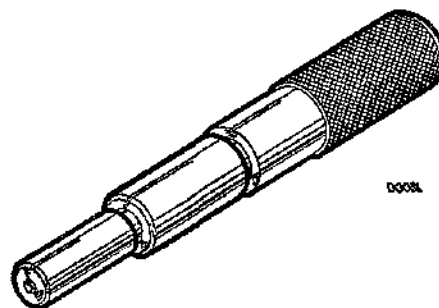

18G 1106. Centralizer—Governor Housing

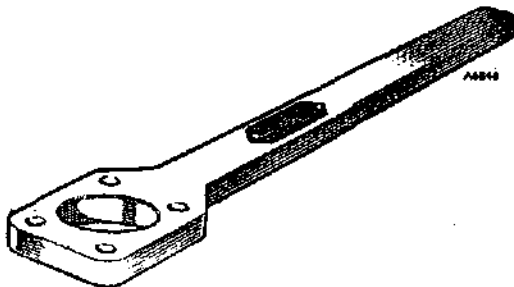

18G 1100. Wrench—Drive Shaft Coupling Flange

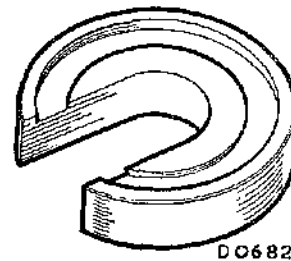

18G 1127. Third Motion Shaft Bearing Remover
(Use on four-speed synchromesh transmission.)

RECOMMENDED LUBRICANTS

RECOMMENDED LUBRICANTS

| Component | *Engine/Transmission Unit, Oil-can and Carburettor(s) | | | Grease Points | Upper Cylinder Lubrication |
|---------------------|---|--|---|--------------------------------|--------------------------------|
| | All temperatures above -12° C. (10° F.) | Temperatures -18° to -7° C. (0° to 20° F.) | All temperatures below -18° C. (0° F.) | | |
| Climatic conditions | | | | All conditions | All conditions |
| BP | BP Super Visco-Static 20W/50 | BP Super Visco-Static 10W/40 | BP Super Visco-Static 5W/20 | BP Energrease L. 2 | BP Upper Cylinder Lubricant |
| CASTROL | Castrol GTX or Castrol XL (20W/50) | Castrolite or Castrol Super | Castrol CR 5W/20 | Castrol Grease LM | Castrollo |
| DUCKHAMS | Duckhams Q20-50 | Duckhams Q5500 | Duckhams Q5-90 | Duckhams L.B. 10 Grease | Duckhams Adcoild Liquid |
| ESSO | Esso Extra Motor Oil 20W/50 | Esso Extra Motor Oil 10W/30 | Esso Extra Motor Oil 5W/20 | Esso Multipurpose Grease H | Esso Upper Cylinder Lubricant |
| FILTRATE | Filtrate Super 20W/50 | Filtrate Super 10W/30 | Filtrate 5W/20 | Filtrate Super Lithium Grease | Filtrate Petroyle |
| MOBIL | Mobilol Special 20W/50 | Mobilol Super 10W/50 | Mobilol 5W/20 | Mobilgrease M.P. | Mobil Upperlube |
| SHELL | Shell Super Motor Oil 100 (20W/50) | Shell Super Motor Oil 101 10W/30 | Shell Winter Special Motor Oil or Shell Super Motor Oil 5W/30 | Shell Retinax A | Shell Upper Cylinder Lubricant |
| STERNOL | Sternol Super W.W. Motor Oil | Sternol W.W. Multigrade 10W/40 | Sternol W.W. Multigrade 5W/20 | Sternol Ambroline LHT 2 Grease | Sternol Magikoyl |

*Including automatic transmission. In no circumstances must any additive be introduced into the lubricants recommended for the automatic transmission.

Steering rack: Use S.A.E. 90 hypoid oil when temperatures are above -18° C. (0° F.).
Use S.A.E. 80 hypoid oil when temperatures are below -18° C. (0° F.).

RECOMMENDED LUBRICANTS

RECOMMENDED LUBRICANTS

| Component | Engine/Synchromesh or Automatic Transmissions*, Distributor, Carburetter Dashpot, Oil Can | | Steering Rack | All Grease Points | Upper Cylinder Lubricant |
|-----------------------------------|---|---|--|--|--------------------------------|
| | All temperatures above -10° C. (10° F.) | All temperatures -15° C. to -5° C. (0° to 20° F.) | | | |
| Climatic conditions predominating | All temperatures above -10° C. (10° F.) | | All conditions | All conditions | All conditions |
| Viscosity requirement | S.A.E. 10W/50 S.A.E. 10W/40 S.A.E. 20/50 or S.A.E. 20W/40 | S.A.E. 10W/50 S.A.E. 10W/40 or S.A.E. 10W/30 | S.A.E. 90 Hypoid | — | — |
| Minimum performance level | MIL-L-2104B | MIL-L-2104B | MIL-L-2105 | Multipurpose Lithium Grease N.L.G.I. Consistency No. 2 | Upper Cylinder Lubricant |
| MOBIL | Mobiloil Special 20W/50 or Super 10W/50 | Mobiloil Super 10W/40 | Mobilube G.X. 90 | Mobilgrease M.P. | Mobil Upperlube |
| ESSO | Esso Extra Motor Oil 20W/50 or Esso Uniflow | Esso Extra Motor Oil 10W/30 or Esso Uniflow | Esso Gear Oil G.P. 90/140 or G.P. 90 | Esso Multipurpose Grease H | Esso Upper Cylinder Lubricant |
| FILTRATE | Filtrate Super 20W/50 | Filtrate Super 10W/30 | Filtrate E.P. Gear 90 | Filtrate Super Lithium Grease | Filtrate Peiroyle |
| BP | BP Super Visco-Static 20W-50 | BP Super Visco-Static 10W-40 or 10W-30 | BP Gear Oil S.A.E. 90 E.P. | BP Energize L. 2 | BP Upper Cylinder Lubricant |
| SHELL | Shell Super Motor Oil 20W/50 | Shell Super Motor Oil 10W/30 | Shell Spirax 90 E.P. | Shell Retinax A | Shell Upper Cylinder Lubricant |
| DUCKHAMS | Duckhams Q. 20-50 | Duckhams Q. 5500 | Duckhams Hypoid 90 | Duckhams L.B. 10 Grease | Duckhams Adcoid Liquid |
| CASTROL | Castrol GTX or Castrol XL 20/50 | Castrolite or Castrol Super | Castrol Hypoy | Castrol LM Grease | Castrollo |
| STERNOL | Sternol Super W.W. Motor Oil | Sternol W.W. Multigrade 10W/40 | Sternol Ambroline E.P. 90 or E.P. 90/140 | Sternol Ambroline Grease L.H.T. 2 | Sternol Magikoyl |

*In no circumstances must any additive be introduced into the lubricants recommended for the automatic transmission.

PRINTED IN ENGLAND BY
THE NUFFIELD PRESS LIMITED
COWLEY, OXFORD
29/22 (81440) 3/71—8,010

