

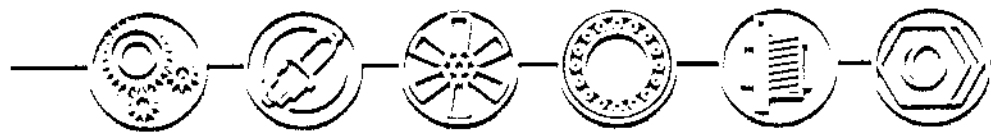

发动机零部件手册

Spare Parts Manual of the Engine



HOVER

哈弗 CUV

前 言

该《发动机零部件手册》可提供国内外广大用户选购零部件时参考，也可帮助您全面了解，各零部件之间的装配关系。

随着技术的发展和用户需求的不断变化，某些零部件可能会相应变更，本零部件手册仅以先行产品为准，对今后的变更不做另行通知。

虽然我们尽力认真编绘本图册，但不能保证所有内容完全正确无误。我们必须保留供货范围、装备和技术方面的修改权。因此，用户不得以本图册中的零件明细表和图解为根据提出任何要求。对于使用本图册而造成的损失，我们皆不负直接和间接责任。

长城汽车股份有限公司确保法律规定的有关权力，保留更改权和解释权。

长城汽车股份有限公司

二零零五年二月

P R E F A C E

Engine Spare Parts Manual is available for reference by quite a few domestic and foreign users when they purchase parts, and also provides you a thorough understanding of the assembly relations among parts .

Some parts might be modified to keep up with the development of technology as well as to meet varying demands of users, this Parts Manual is only based on current products, and further notices shall not be made for future changes.

We shall not guarantee all the contents fully right without fault although we have tried to compile and draw the illustrated manual carefully. And we must reserve the right to make changes in the scope of supply, installation, and technology. Therefore, users shall not put forward any requirement with respect to the parts lists and illustrations in this illustrated manual. And we shall not bear any direct or indirect responsibility for the loss caused by use of this illustrated manual.

Great Wall Motor Company Limited guarantees the related rights specified by law, and reserves the rights of modification and interpretation.

Great Wall Motor Company Limited







February 2005

目 录

11. 发动机		14. 冷却	
010. 发动机总成	4	110. 水泵	40
020. 短发动机总成	6	120. 水管及节温器	42
090. 发动机大修密封套件	8	15. 进气与排气	
100. 液体密封垫	10	210. 进气歧管	44
110. 摇臂盖	12	310. 排气歧管	46
120. 气缸盖	14	710. 排放控制	48
130. 气缸体	16	16. 发动机电气	
140. 后盖板及油底壳	20	010. 起动机	50
210. 活塞及曲轴	24	110. 发电机	52
230. 凸轮轴与气门	26	220. 火花塞、电缆及线圈	54
250. 平衡轴	30	410. 电子控制	56
320. 机油压力开关	32	21. 离合器	
12. 润滑		010. 离合器及连接零部件	58
110. 机油泵与机油滤清器	34		
13. 燃油			
550. 燃油分配管总成及节气门体	38		

11. ENGINE		15. INTAKE EXHAUST	
010. ENGINE ASSY	4	210. INLET MANIFOLD	44
020. SHORT ENGINE ASSY	6	310. EXHAUST MANIFOLD	46
090. ENGINE OVERHAUL GASKET KIT	8	710. EMISSION CONTROL	48
100. LIQUID GASKET	10	16. ENGINE ELECTRICAL	
110. ROCKET COVER	12	010. STARTER	50
120. CYLINDER HEAD	14	110. ALTERNATOR	52
130. CYLINDER BLOCK	16	220. SPARK PLUG,CABLE & COIL	54
140. COVER,REAR BLOCK PLATE & OIL PAN	20	410. ELECTRICAL CONTROL	56
210. PISTON & CRANKSHAFT	24	21. CLUTCH	
230. CAMSHAFT & VALVE	26	010. CLUTCH & CONNECTING PARTS	58
250. BALANCER	30		
320. OIL PRESS SWITCH OR GAUGE UNIT	32		
12. LUBRICATION			
110. OIL PUMP & OIL FILTER	34		
13. FUEL			
550. PIPE ASSY:FUEL DELIVERY & THROTTLE BODY	38		
14. COOLING			
110. WATER PUMP	40		
120. WATER PIPE & THERMOSTAT	42		

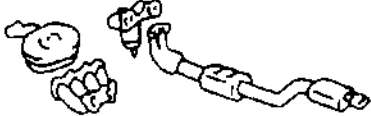
组件图解索引

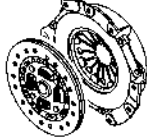
11 发动机 ENGINE 	12 润滑 LUBRICATION 	13 燃油 FUEL 	
14 冷却 COOLING 	15 进气与排气 INTAKE & EXHAUST 	16 发动机电气 ENGINE ELECTRICAL 	21 离合器 CLUTCH 

11 发动机 ENGINE	4
12 润滑 LUBRICATION	34
13 燃油 FUEL	38
14 冷却 COOLING	40
15 进气与排气 INTAKE & EXHAUST	44
16 发动机电气 ENGINE ELECTRICAL	50
21 离合器 CLUTCH	58

怎样阅读图解页及零件清单

① 组件号码

② 组件名称

15 - 310 排气歧管 EXHAUST MANIFOLD

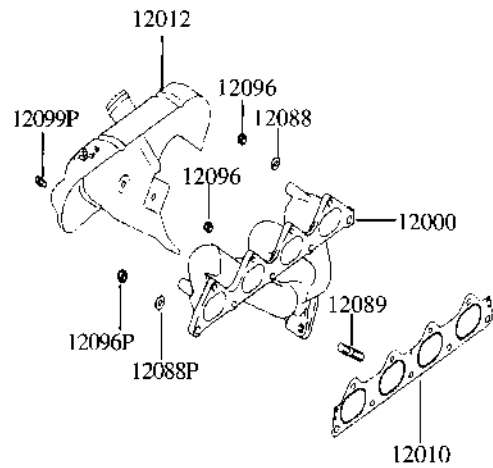

零件名称代号 FROM-UP-TO	零部件编号 PARTCODE	零部件名称 DESCRIPTION	用量 / 台 QTY	替换 REP	备注 REMARK
12000		排气歧管 MANIFOLD EXHAUST			
12010	SMR188194	排气歧管垫 GASKET MANIFOLD EXHAUST	1		
12012	SMD181032	排气歧管盖 COVER, EXHAUST MANIFOLD	1		

③ 零件名称代号(主号码) ⑤ 零件代号

④ 零件名称

⑦ 数量

⑥ 替换

⑧ 备注

① 组件号码

本栏提供组件的号码(主、辅组件号码)

② 组件名称

本栏提供组件的名称。

③ 零件名称代号(主号码)

本栏显示主要号码,按零件号码清单中的零件名称来联结图解零件。(如要得到零件名称的编号组成及意义,请参阅零件名称编号的有关资料)。

④ 零件名称

本栏提供零件的名称(包括任何补充名称)

⑤ 零件号码

本栏提供发动机及变速箱所用零件的号码。替换零件号码以括号()表示。

⑥ 替换

转换的零件可能是兼容或不兼容的,如果新零件可以取代旧的,它被称为替换零件并分类如下:

O: 新及旧的零件同时可用。

Y: 新零件可取代旧零件,但旧零件只能用于旧型号的汽车

≡: 新及旧零件都必须同时以其它有关零件取代。

⑦ 数量

本栏提供所用零件的数量。

⑧ 备注

1.这部分提供以下附加资料,是由于读者可能无法仅从生产期、型号及适用等资料来辨别零件号码。

- 例如:
- 形状FLANGE(凸缘)
 - 颜色L—GRAY(L—灰色)
 - 规格50A
 - 物料RUBBER(橡胶)
 - 尺寸8 × 40
 - 选择使用零部件CC
 - 内部编号INT; 0.2H
 - 外部编号EXT; W01
 - 选择编号OP; R09

2.若根据维修零件通讯所载,有数个新及旧的零件被取代,将提供“维修零件通讯目录号码”。

11 - 010 发动机总成 ENGINE ASSY

01000A

发动机总成

发动机总成是成套的修理用零件，这套零件与用于汽车生产而批量制造的成套发动机完全相同。因此，那些不直接装配到发动机上的零部件(如变速箱、起动机等)和空气滤清器不包括在内。

ENGINE ASSEMBLY

The Engine Assembly is a unit service part that is actually same as the unit engine mass – produced for installation on the vehicles currently in production. Therefore it does not include those parts which are not directly assembled to the engine (such as transmission, starting motor) and air cleaner.

发动机总成 ENGINE ASSY

零件名称代号 FROM-UP-TO	零部件编号 PARTCODE	零部件名称 DESCRIPTION	用量 / 台 QTY	替换 REP	备注 REMARK
01000A	1016100-E05	发动机总成 ENGINE ASSY			4G64-D-Y7

11-020 短发动机总成 SHORT ENGINE ASSY

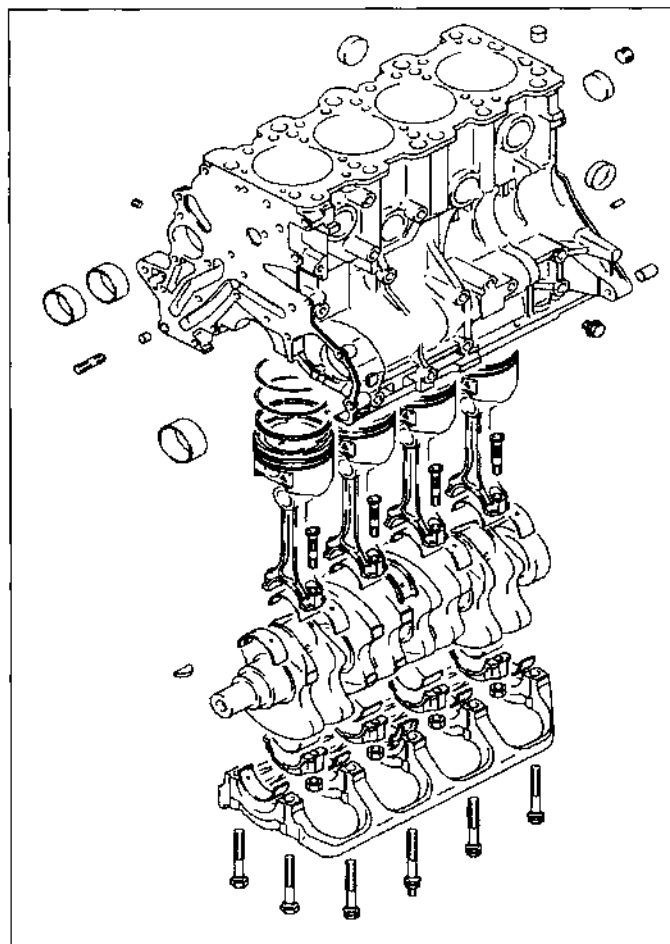

01010A

短发动机总成 SHORT ENGINE ASSY

零件名称代号 FROM-UP-TO	零部件编号 PARTCODE	零部件名称 DESCRIPTION	用量/台 QTY	替换 REP	备注 REMARK
01010A	1002100-E07	短发动机总成 ENGINE ASSY,SHORT	1		

11-090 发动机大修密封套件 ENGINE OVERHAUL GASKET KIT

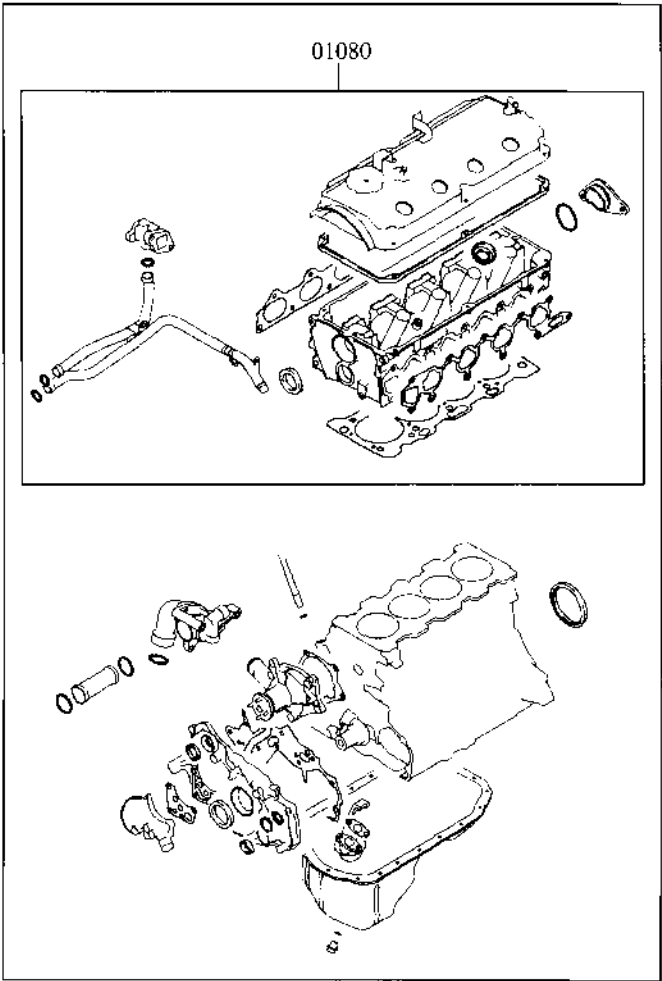

发动机大修密封套件 ENGINE OVERHAUL GASKET KIT

零件名称代号 FROM-UP-TO	零部件编号 PARTCODE	零部件名称 DESCRIPTION	用量/台 QTY	替换 REP	备注 REMARK
01070	SMD973157	发动机大修密封套件 GASKET KIT,ENG OVERHAUL	1		
01080	SMD973156	发动机上侧大修密封衬垫 GASKET KIT,ENG OVERHAUL、UPR	1		

11 - 100 液体密封垫 LIQUID GASKET

01090

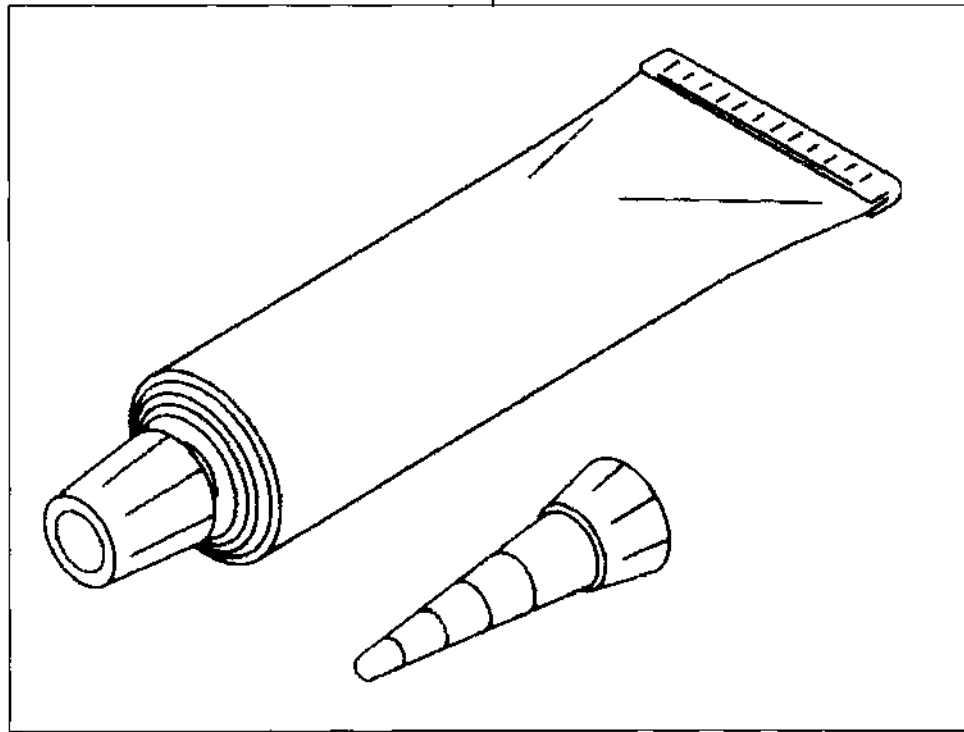

液体密封垫 LIQUID GASKET

零件名称代号 FROM-UP-TO	零部件编号 PARTCODE	零部件名称 DESCRIPTION	用量/台 QTY	替换 REP	备注 REMARK
01090	SMD970389	发动机液体密封胶 LIQUID GASKET,ENG	1		100G

11 - 110 摇臂盖 ROCKER COVER

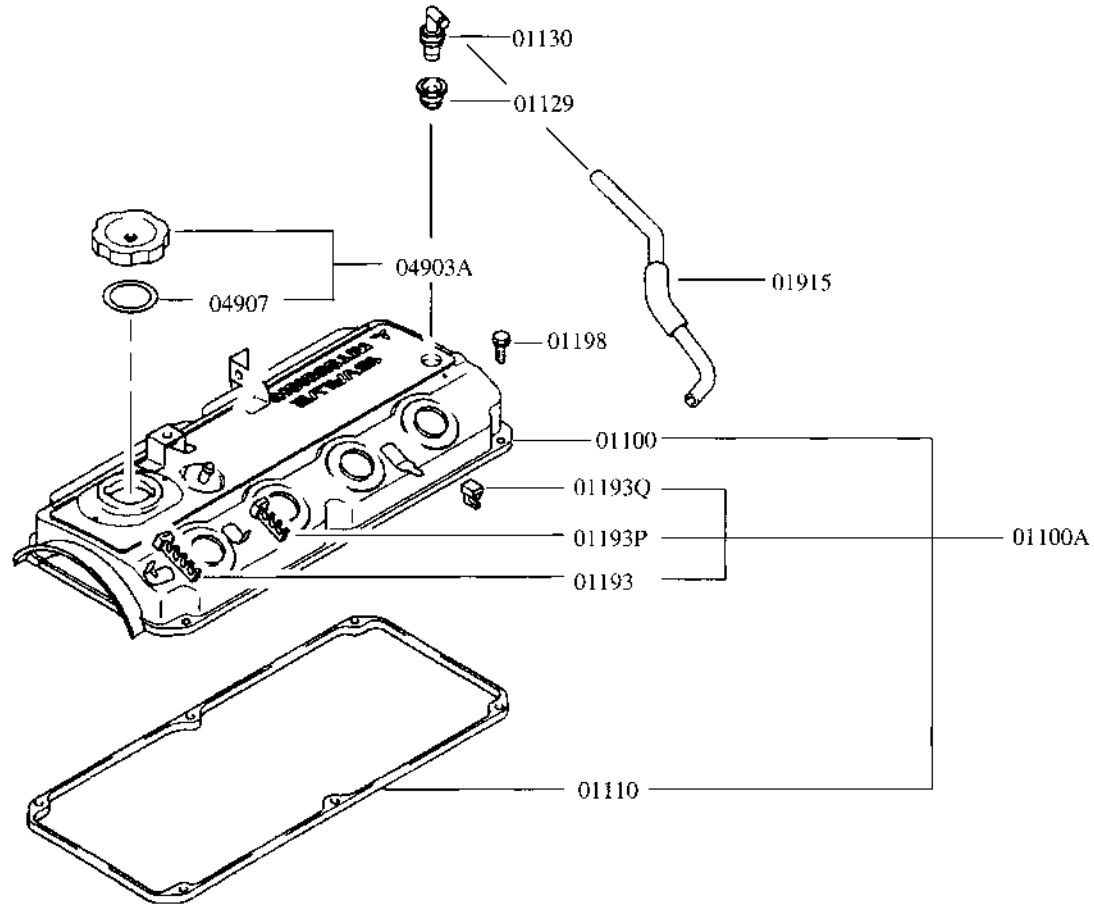

摇臂盖 ROCKER COVER

零件名称代号 FROM-UP-TO	零部件编号 PARTCODE	零部件名称 DESCRIPTION	用量/台 QTY	替换 REP	备注 REMARK
01100A	SMW250134	摇臂盖组件 COVER ASSY,ROCKER	1		
01100	SMD312951	摇臂盖 COVER,ROCKER	1		
01110	SMD188435	摇臂盖垫 GASKET,ROCKER COVER	1		
01129	SMD179909	P.C.V 阀垫 GASKET,PCV VALVE	1		
01130	SMD183547	P.C.V 阀 VALVE,PCV	1		
01193	SMD129546	电缆夹 CLAMP,CABLE	2		
01193Q	SMD164733	电缆夹 CLAMP,CABLE	1		
01198	SMF244826	摇臂盖螺栓 BOLT,ROCKER COVER	6		带垫 M6 × 20
01915	SMD313710	P.C.V 软管 HOSE,P.C.V	1		
04903A	SMD132260	加油口盖 CAP,OIL FILLER	1		
04907	SMD103148	加油口盖垫 GASKET,OIL FILLER CAP	1		

11 - 120 气缸盖 CYLINDER HEAD

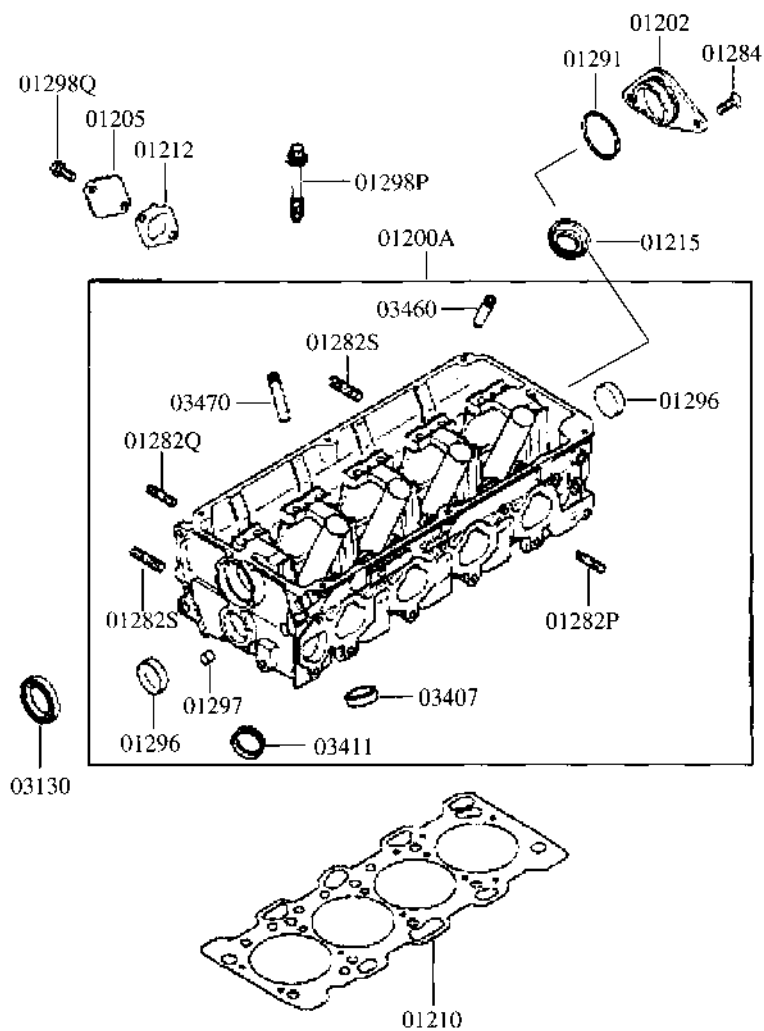

气缸盖 CYLINDER HEAD

零件名称代号 FROM-UP-TO	零部件编号 PARTCODE	零部件名称 DESCRIPTION	用量 / 台 QTY	替换 REP	备注 REMARK
01200A	SMD305479	气缸盖组件 HEAD ASSY,ENG CYLINDER	1		
01202	SMD188738	止推盖 CASE,THRUST	1		
01210	SMD346925	气缸垫 GASKET,CYLINDER HEAD	1		
01215	SMD198128	油封 OIL SEAL	4		
01282P	MS401428	双头螺柱 STUD(8 × 28)	3		M8 × 28
01282Q	SMD005317	双头螺柱 STUD	7		M8 × 28
01282S	SMD146938	双头螺柱 STUD(10 × 28)	2		M10 × 28
01284	MF201595	机制螺钉 SCREW,MACHINE	2		M8 × 20
01291	MF520405	O 型环 O-RING	1		D= φ 45
01296	MF665541	密封盖 CAP,SEALING	2		密封 φ 35
01297	MS471104	定位套 BUSHING,KNOCK	2		M8 × 9
01298P	SMD191470	气缸盖螺栓组件 BOLT ASSY,CYLINDER HEAD	10		带垫 M11 × 97
03130	SMD133317	油封 OIL SEAL	1		
03407	SMD188579	排气门座 SEAT,EXHAUST VALVE	8		加大 0.30
	SMD188580	排气门座 SEAT,EXHAUST VALVE	CC		或加大 0.60
03411	SMD191384	进气门座 SEAT,INLET VALVE	8		加大 0.30
	SMD191385	进气门座 SEAT,INLET VALVE	CC		或加大 0.60
03460	SMD364870	进气门导管 GUIDE,INLET VALVE	8		加大 0.05
	SMD318940	进气门导管 GUIDE,INLET VALVE	CC		或加大 0.25
	SMD364871	进气门导管 GUIDE,INLET VALVE	CC		或加大 0.50
03470	SMD364740	排气门导管 GUIDE,EXHAUST VALVE	8		加大 0.05
	SMD318689	排气门导管 GUIDE,EXHAUST VALVE	CC		或加大 0.25
	SMD364741	排气门导管 GUIDE,EXHAUST VALVE	CC		或加大 0.50
01298Q	SMF140224	法兰螺栓 BOLT, FLANGE	2		M8 × 18
01205	SMD327961	盖 COVER	1		
01212	SMD327960	气缸盖水孔衬垫 GASKET,CYLINDER HEAD WATER HOLE COVER	1		

11 - 130 气缸体 CYLINDER BLOCK

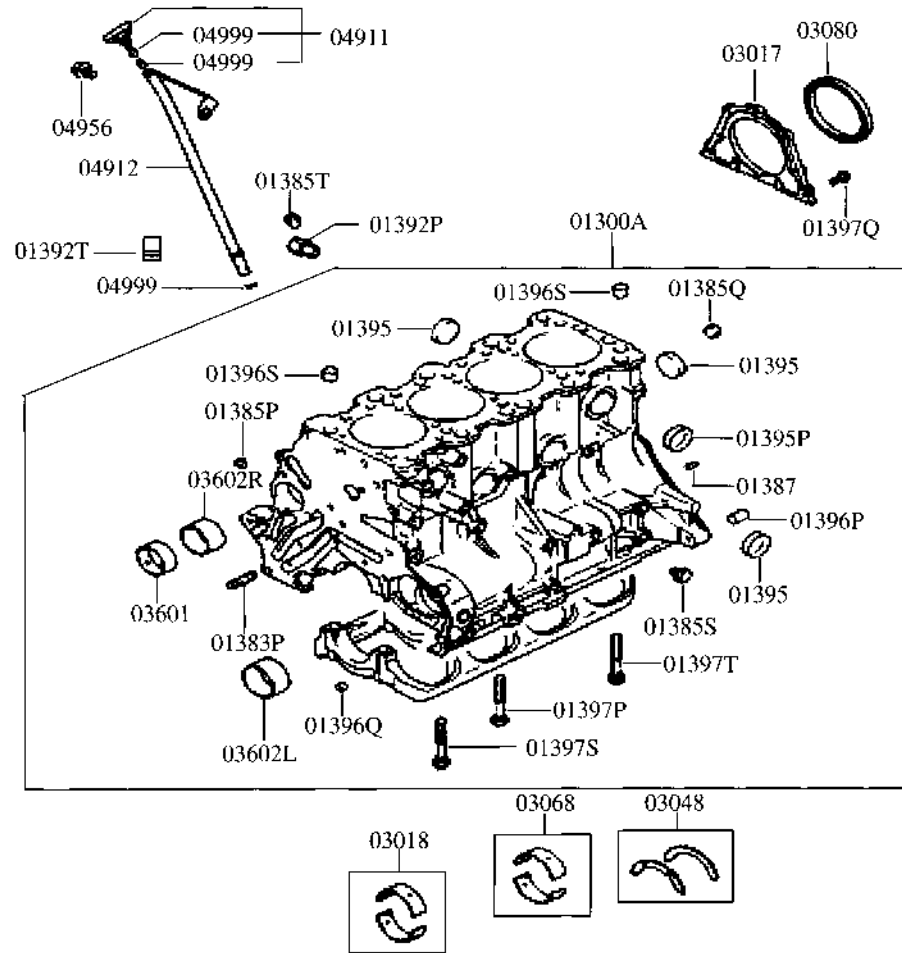

气缸体 CYLINDER BLOCK

零件名称代号 FROM-UP-TO	零部件编号 PARTCODE	零部件名称 DESCRIPTION	用量/台 QTY	替换 REP	备注 REMARK
01300A	SMD375937	气缸体组件 BLOCK ASSY, CYLINDER	1		
01385P	SMD378291	锥形塞 PLUG, TAPER	2		锥 1/16
01385Q	SMD040338	锥形塞 PLUG, TAPER	1		锥 3/8
01385S	SMD065945	塞 PLUG	1		螺纹 M10 × 12
01385T	SMD024256	锥形塞 PLUG, TAPER	1		锥 1/8
01387	MF472403	定位销 PIN, DOWEL	2		定位销 ϕ 6 × 14
01392P	SMD314121	放水塞 JOINT, WATER DRAIN	1		
01395	MF665541	密封盖 CAP, SEALING	7		密封, ϕ 35
01395P	SMD000427	密封盖 CAP, SEALING	2		密封, ϕ 40
01396P	SMD020260	定位套 BUSHING, KNOCK	2		ϕ 10.5 × 19.3
01396Q	MS471104	定位套 BUSHING, KNOCK	2		ϕ 8 × 9
01396S	MS471111	定位套 BUSHING, KNOCK	2		M12 × 13
01397P	SMD153368	主轴承盖螺栓 BOLT, BEARING CAP	7		M10 × 70
01397Q	MF140204	法兰螺栓 BOLT, FLANGE	5		法兰 M6 × 14
01397S	SMD177374	主轴承盖螺栓 BOLT, BEARING CAP	1		M10 × 70
01397T	SMD183236	主轴承盖螺栓 BOLT, BEARING CAP	2		法兰 M10 × 70
03017	SMD172170	后油封盖 CASE, REAR OIL SEAL	1		
03018	SMD327493	曲轴轴承组(1、2、4、5轴颈) BEARING, SET CRANKSHAFT STD	4		标准(S1),绿
	SMD327494	曲轴轴承组(1、2、4、5轴颈) BEARING, SET CRANKSHAFT STD	CC		或标准(S2),黄
	SMD327495	曲轴轴承组(1、2、4、5轴颈) BEARING, SET CRANKSHAFT STD	CC		或标准(S3),无色
	SMD327496	曲轴轴承组(1、2、4、5轴颈) BEARING, SET CRANKSHAFT STD	CC		或标准(S4),兰
	SMD327497	曲轴轴承组(1、2、4、5轴颈) BEARING, SET CRANKSHAFT STD	CC		或标准(S5),红
03048	SMD351820	曲轴止推轴承组 BEARING, SET CRANKSHAFT THRUST	1		
01392T	SMD014929	锥形塞 PLUG, TAPER	1		锥 1/8

气缸体 CYLINDER BLOCK

零件名称代号 FROM-UP-TO	零部件编号 PARTCODE	零部件名称 DESCRIPTION	用量/台 QTY	替换 REP	备注 REMARK
03068	SMD327493	中央曲轴轴承组 BEARING, SET CRANKSHAFT STD	CC		或标准(S1),绿
	SMD327494	中央曲轴轴承组 BEARING, SET CRANKSHAFT STD	CC		或标准(S2),黄
	SMD327495	中央曲轴轴承组 BEARING, SET CRANKSHAFT STD	CC		或标准(S3),无色
	SMD327496	中央曲轴轴承组 BEARING, SET CRANKSHAFT STD	CC		或标准(S4),兰
	SMD351826	中央曲轴轴承组 BEARING, SET CRANKSHAFT STD	1		标准(S0),黑
03080	SMD359158	油封 OIL SEAL	1		
03602L	SMD040598	左后轴承 BEARING,BALANCER SHAFT,RR LH	1		标准
	SMD082302	左后轴承 BEARING,BALANCER SHAFT,RR LH	CC		加大 1.0
03602R	SMD103722	右后轴承 BEARING,BALANCER SHAFT,RR RH	1		标准
	SMD103723	右后轴承 BEARING,BALANCER SHAFT,RR RH	CC		加大 1.0
04911	SMW250384	机油尺杆组件 ROD ASSY, OIL LEVEL GAUGE	1		
04912	SMW250386	机油尺导管 GUIDE, OIL LEVEL GAUGE	1		
04956	MF140021	法兰螺栓 BOLT, FLANGE	1		法兰 M8 × 12
04999	SMD317089	O型环 O - RING	1		导管侧
03601	SMD040597	右前轴承 BEARING,BALANCER SHAFT ,FR	1		标准
	SMD082301	右前轴承 BEARING,BALANCER SHAFT ,FR	CC		加大 1.0

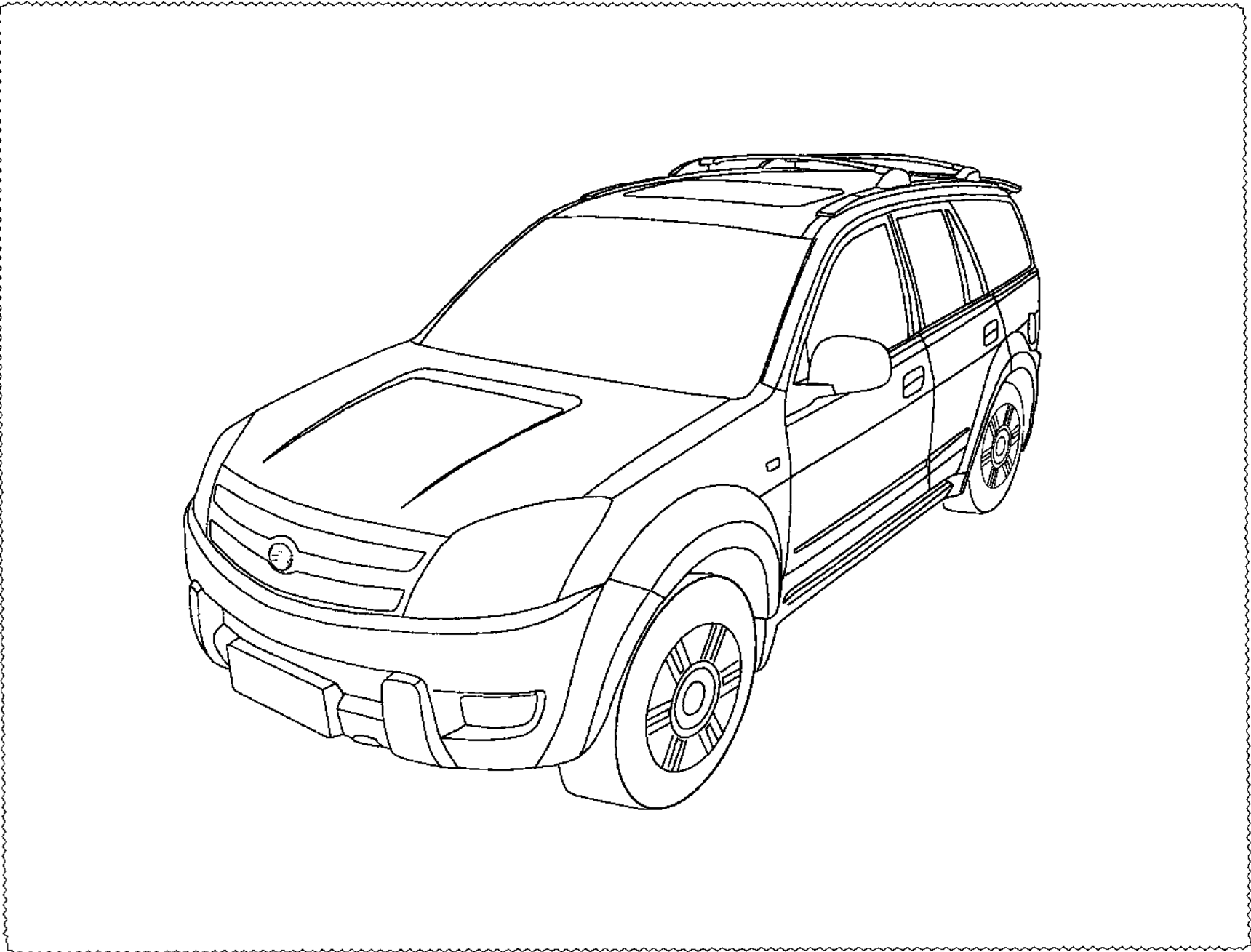

11-140 后盖板及油底壳 COVER, REAR PLATE & PAN

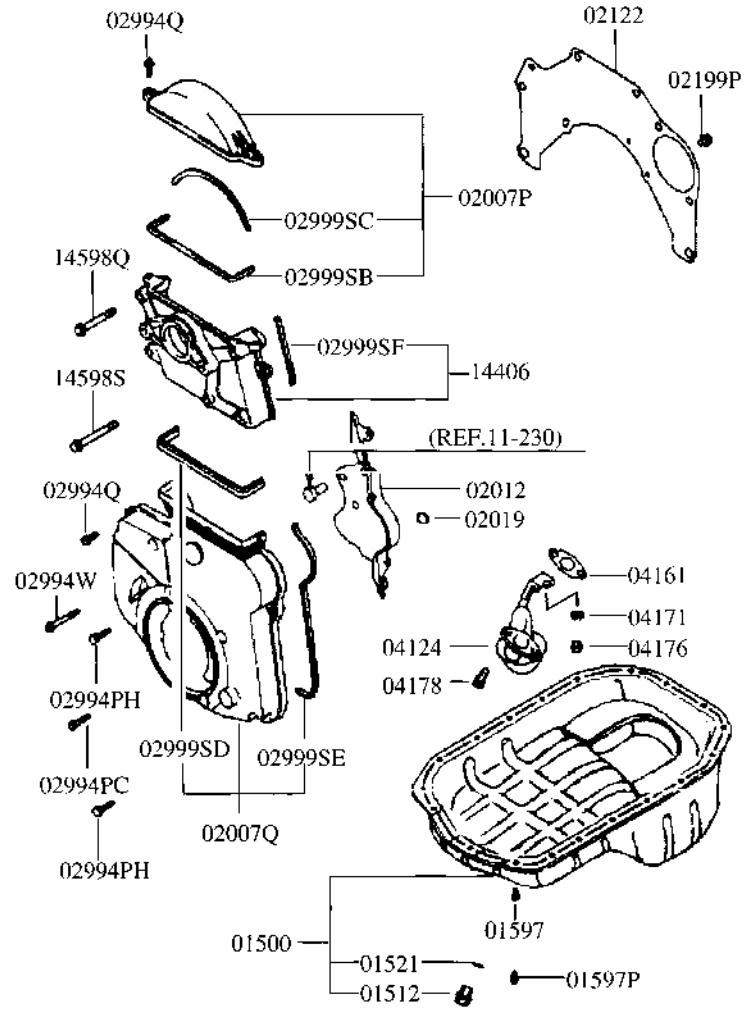

后盖板及油底壳 COVER, REAR PLATE&PAN

零件名称代号 FROM-UP-TO	零部件编号 PARTCODE	零部件名称 DESCRIPTION	用量/台 QTY	替换 REP	备注 REMARK
01500	SMW250436	油底壳组件 PAN ASSY,OIL	1		
01512	SMW250218	放油塞 PLUG,OIL DRAIN	1		
01521	SMW250219	放油塞垫 GASKET,OIL DRAIN PLUG	1		
01597	SMD097012	法兰螺栓 BOLT,FLANGE	17		法兰 M6 × 10
01597P	MF140201	法兰螺栓 BOLT,FLANGE	2		法兰 M6 × 8
02007P	SMD310415	正时齿带前上盖组件 COVER ASSY,T/BELT,FRONT UPPER	1		
02007Q	SMD331250	正时齿带前下盖组件 COVER ASSY,T/BELT,FRONT LOWER	1		
02012	SMD315540	正时齿带后盖 COVER,T/BELT,REAR	1		
02019	SMD129345	橡胶塞 PLUG,RUBBER	1		橡胶, φ 9
02122	SMD300902	后盖板 PLATE,REAR	1		
02199P	MF140202	法兰螺栓 BOLT,FLANGE	2		法兰 M6 × 10
02994PC	MF140210	法兰螺栓 BOLT,FLANGE	1		法兰 M6 × 28
02994PH	MF247868	带垫螺栓 BOLT,WASHER ASSEMBLED	2		带垫 M6 × 25
02994Q	MF140206	法兰螺栓 BOLT,FLANGE	8		法兰 M6 × 18
02994W	MF140217	法兰螺栓 BOLT,FLANGE	1		法兰 M6 × 50
02999SB	SMD191997	正时齿带盖垫 GASKET,TIMING BELT COVER	1		
02999SC	SMD310589	正时齿带盖垫 GASKET,TIMING BELT COVER	1		
02999SD	SMD304419	正时齿带下盖垫 GASKET,T/BELT COVER LOWER	1		
02999SE	SMD310591	正时齿带盖垫 GASKET,TIMING BELT COVER	1		
02999SF	SMD188123	正时齿带盖垫 GASKET,TIMING BELT COVER	1		
04124	SMW250170	机油集滤器组件 SCREEN ASSY,OIL	1		
04161	SMD183240	机油集滤器垫 GASKET,OIL SCREEN	1		
04171	MF450405	机油集滤器垫圈 WASHER,OIL STRAINER	1		
04176	MF430005	机油集滤器螺母 NUT,OIL STRAINER	1		M8
04178	MS241071	带垫螺栓 BOLT,WASHER ASSEMBLED	2		带垫 M8 × 20
14406	SMW250184	点火线圈支架组件 BRACKET ASSY, IGNITION COIL	1		

后盖板及油底壳 COVER, REAR PLATE&PAN

零件名称代号 FROM-UP-TO	零部件编号 PARTCODE	零部件名称 DESCRIPTION	用量 / 台 QTY	替换 REP	备注 REMARK
14598Q	MF140237	法兰螺栓 BOLT,FLANGE	3		法兰 M8 × 60
14598S	MF140239	法兰螺栓 BOLT,FLANGE	1		法兰 M8 × 70

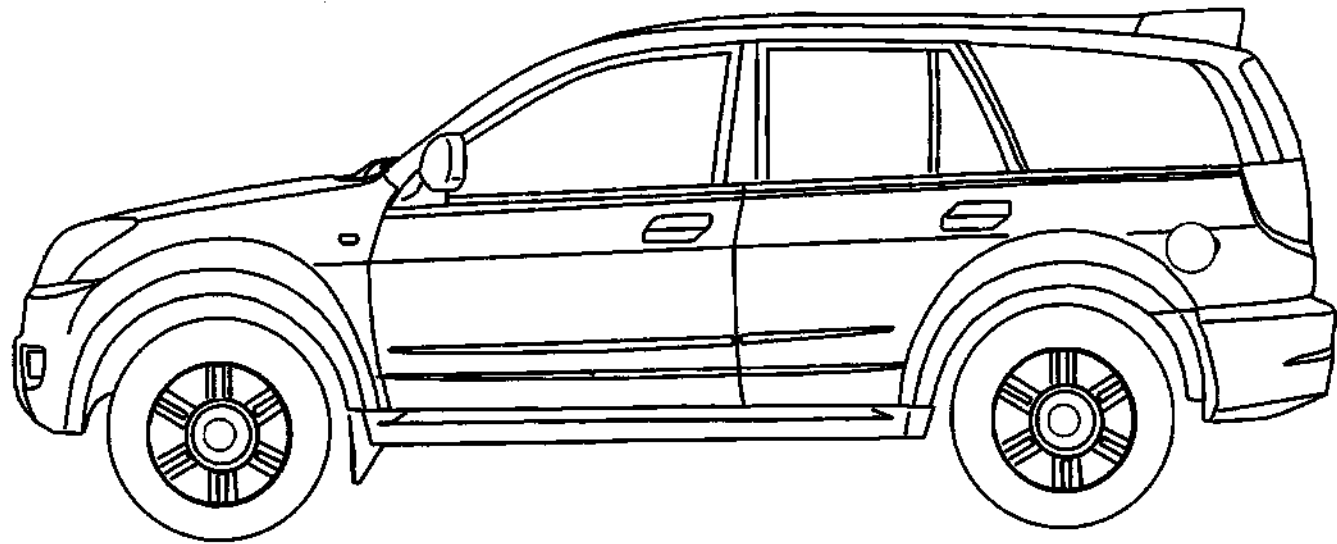

11-210 活塞及曲轴 PISTON & CRANKSHAFT

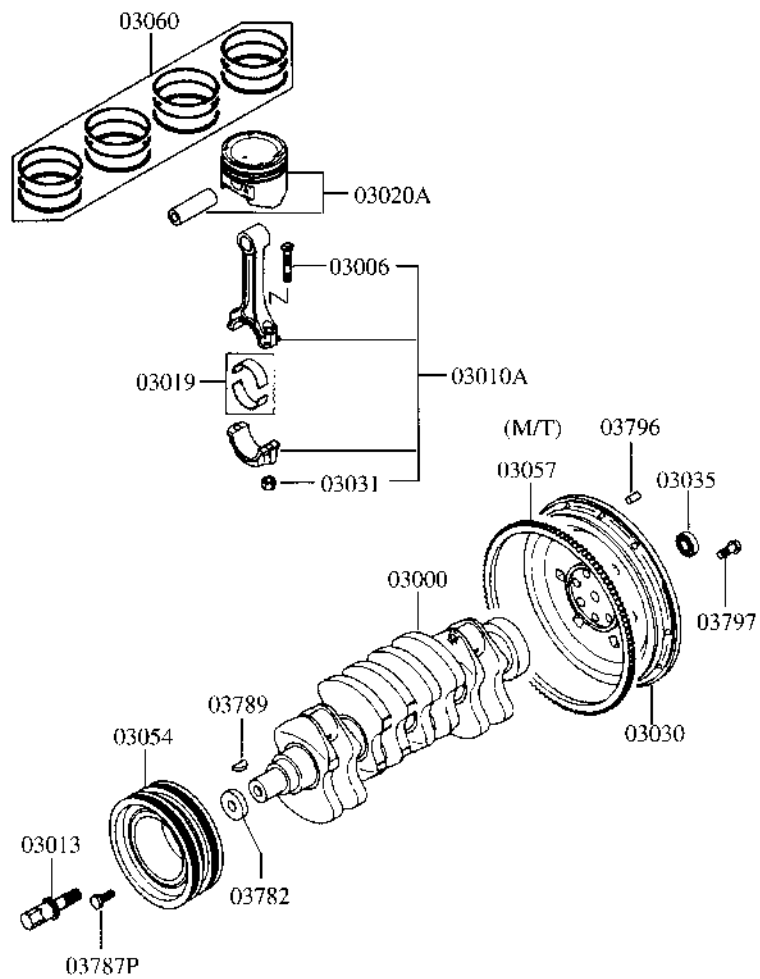

活塞及曲轴 PISTON & CRANKSHAFT

零件名称代号 FROM-UP-TO	零部件编号 PARTCODE	零部件名称 DESCRIPTION	用量/台 QTY	替换 REP	备注 REMARK
03000	SMD346026	曲轴组件 CRANKSHAFT ASSY	1		SMW250060 选用
03006	SMD193029	连杆螺栓 BOLT,CONNECTING	8		
03010A	SND193027	连杆组件 CONNECTING ROD ASSY	4		
03013	SMD376614	曲轴皮带轮螺栓 BOLT,CRANKSPROCKET	1		M14 × 40
03019	SMD327503	连杆轴承组 BEARING,CONROD	4		标准(S1),黄
	SMD327504	连杆轴承组 BEARING,CONROD	CC		标准(S2),无色 标
	SMD327505	连杆轴承组 BEARING,CONROD	CC		准(S3),兰
03020A	SMD303070	活塞和销 PISTON WITH PIN	4		标准 A
	SMD303071	活塞和销 PISTON WITH PIN	CC		标准 B
	SMD303072	活塞和销 PISTON WITH PIN	CC		标准 C
	SMD303077	活塞和销 PISTON WITH PIN	CC		加大 0.50
	SMD303079	活塞和销 PISTON WITH PIN	CC		加大 1.00
03030	SMW250225	飞轮 FLYWHEEL	1		
03031	SMD144215	螺母 NUT	8		M8
03035	SMD335444	球轴承 BEARING,BALL	1		
03054	SMD306158	曲轴减震皮带轮组件 PULLEY ASSY,TORSIONAL DAMPER	1		带筋:(3)
03057	SMD024812	飞轮齿圈 GEAR,RING	1		
03060	SMD194597	活塞环组 RING SET,PISTON	1		标准
	SMD194599	活塞环组 RING SET,PISTON	CC		加大 0.50
	SMD194601	活塞环组 RING SET,PISTON	CC		加大 1.00
03782	SMD377400	专用垫圈 WASHER,SPECIAL	1		平,14.5
03787P	MS240211	带垫螺栓 BOLT WASHER ASSEMBLED	4		带垫,M8 × 25 半
03789	SMD008959	键 KEY	1		圆键, 5 × 9
03796	SMD472404	定位销 PIN,DOWEL	3		定位销 φ 6 × 24
03797	SMD302074	飞轮螺栓 BOLT,FLYWHEEL	7		法兰 M12 × 21.2

11-230 凸轮轴与气门 CAMSHAFT & VALVE

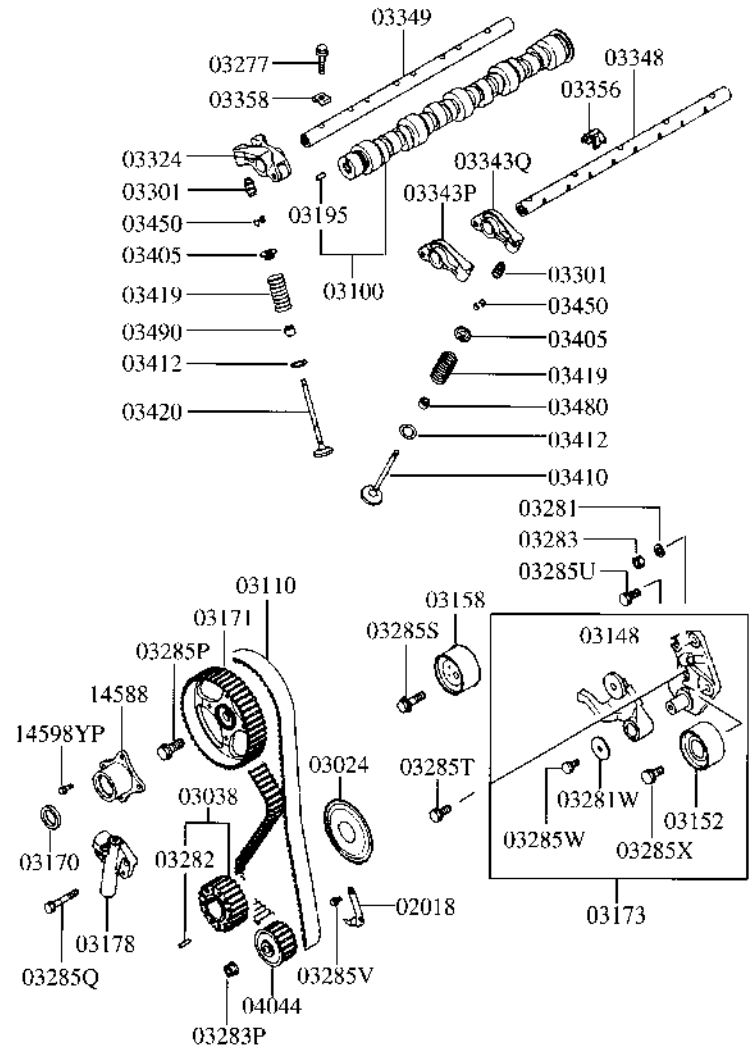

凸轮轴与气门 CAMSHAFT & VALVE

零件名称代号 FROM-UP-TO	零部件编号 PARTCODE	零部件名称 DESCRIPTION	用量/台 QTY	替换 REP	备注 REMARK
02018	SMD315101	正时指示器支架 BRACKET,TIMING INDICATOR	1		
03024	SMD188501	法兰 FLANGE	1		
03038	SMD326852	曲轴正时齿带轮组件 SPROCKET ASSY,CRANKSHAFT	1		
03100	SMD338231	凸轮轴组件 CAMSHAFT ASSY	1		
03110	SMD182294	正时齿带 BELT,TIMING	1		
03148	SMD170402	张紧器臂组件 ARM ASSY,TENSIONER	1		
03152	SMD156604	惰轮 PULLEY,IDLER	1		
03158	SMD182537	张紧轮 PULLEY,TENSIONER	1		
03170	SMD168059	油封 OIL SEAL	1		
03171	SMD310813	凸轮轴正时齿带轮 SPROCKET,CAMSHAFT	1		
03173	SMD192731	张紧轮支架组件 BRACKET ASSY,TENSIONER PULLEY	1		
03178	SMD308587	自动张紧器 TENSIONER,AUTO	1		
03195	SMD158443	定位销 PIN,DOWEL	1		定位销 $\phi 6 \times 14$
03277	SMD162682	法兰螺栓 BOLT,FLANGE	13		法兰 M8 \times 35
03281W	SMD129421	平垫圈 WASHER,PLAIN	1		平 8
03282	MF472571	弹簧销 SPRING PIN	1		$\phi 5 \times 20$
03283W	MF241282	带垫螺栓 BOLT,WASHER ASSEMBLED	1		带垫 M10 \times 25
03283P	SMD095237	法兰螺母 NUT,FLANGE	1		M10
03285P	SMD301352	法兰螺栓 BOLT,FLANGE	1		
03285Q	SMD129350	法兰螺栓 BOLT,FLANGE	2		法兰 M8 \times 51
03285S	MF244884	带垫螺栓 BOLT,WASHER ASSEMBLED	1		带垫 M10 \times 35
03285T	MF241281	带垫螺栓 BOLT,WASHER ASSEMBLED	1		带垫 M10 \times 22
03285U	SMD194109	密封螺栓 BOLT,SEAL	1		带密封 M10 \times 22

凸轮轴与气门 CAMSHAFT & VALVE

零件名称代号 FROM-UP-TO	零部件编号 PARTCODE	零部件名称 DESCRIPTION	用量/台 QTY	替换 REP	备注 REMARK
03285V	MF140202	法兰螺栓 BOLT,FLANGE	2		法兰 M6 × 10
03285W	MF241251	带垫螺栓 BOLT,WASHER ASSEMBLED	1		带垫 M8 × 16
03285X	MF241281	带垫螺栓 BOLT,WASHER ASSEMBLED	1		带垫 M10 × 22
03301	SMD377561	液压挺柱 ADJUSTER,ASSY LASH	16		
03324	SMD178782	摇臂组件 "C" ROCKER ARM ASSY "C"	4		
03343P	SMD167980	摇臂组件 "A" ROCKER ARM ASSY "A"	4		
03343Q	SMD167981	摇臂组件 "B" ROCKER ARM ASSY "B"	4		
03348	SMD187818	进气摇臂轴 SHAFT,ROCKER ARM.IN.	1		
03349	SMD187819	排气摇臂轴 SHAFT,ROCKER ARM.EX.	1		
03356	SMD166768	进气摇臂轴弹簧 SPRING,ROCKER SHAFT,INLET	4		
03358	SMD169459	摇臂轴盖 CAP,ROCKER SHAFT	13		
03405	SMD159209	气门弹簧上座 RETAINER,VALVE SPRING	16		
03410	SMD159502	进气门 VALVE,INLET	8		330
03412	SMD151527	进气门弹簧座 SEAT,VALVE SPRING,INLET	16		
03419	SMD314078	气门弹簧 SPRING,VALVE	16		
03420	SMD199193	排气门 VALVE,EXHAUST	8		29
03450	SMD151369	气门弹簧锁夹 LOCK,VALVE SPRING RETAINER	32		
03480	SMD184303	气门油封 SEAL,VALVE STEM	8		橡胶 5.2
03490	SMD184303	气门油封 SEAL,VALVE STEM	8		橡胶 5.2
04044	SMD124762	机油泵齿带轮 SPROCKET,OIL PUMP	1		
14588	SMD311567	凸轮轴正时齿带轮定位套 SPACER,CAMSHAFT SPROCKET	1		
14598YP	MF140204	法兰螺栓 BOLT,FLANGE	4		法兰 M6 × 14

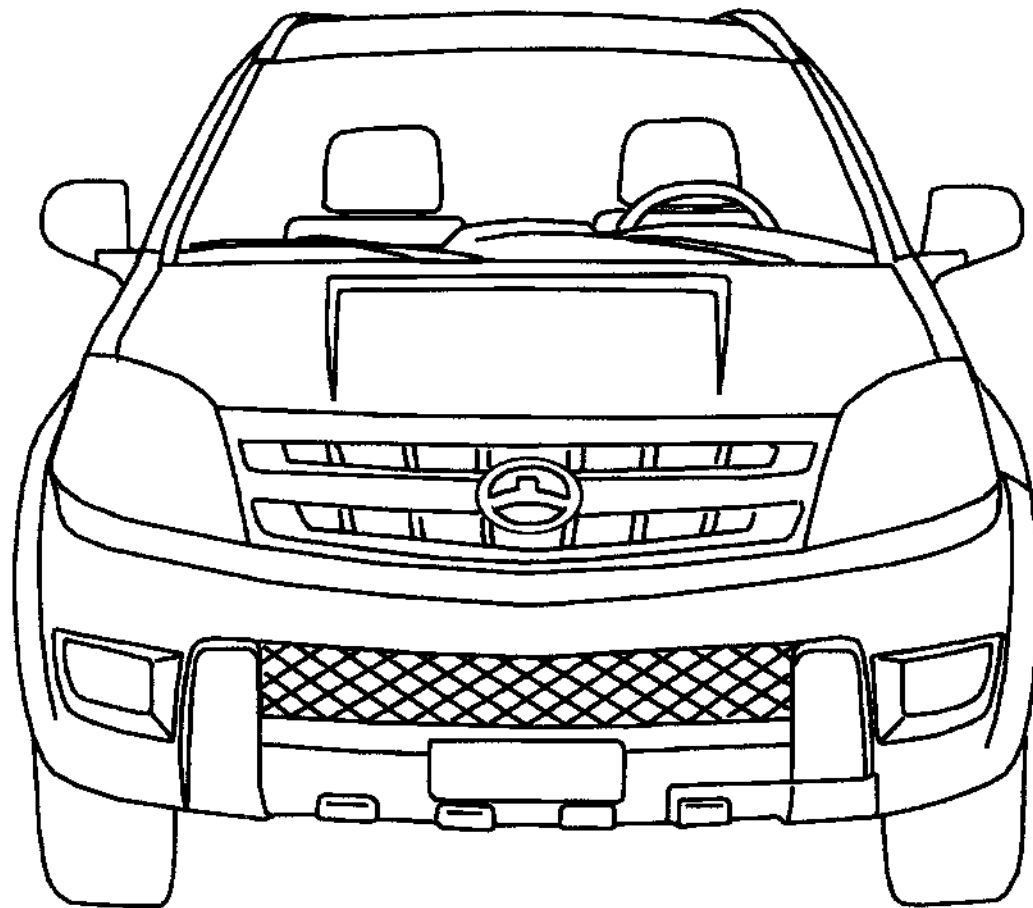

11-250 平衡轴 BALANCER

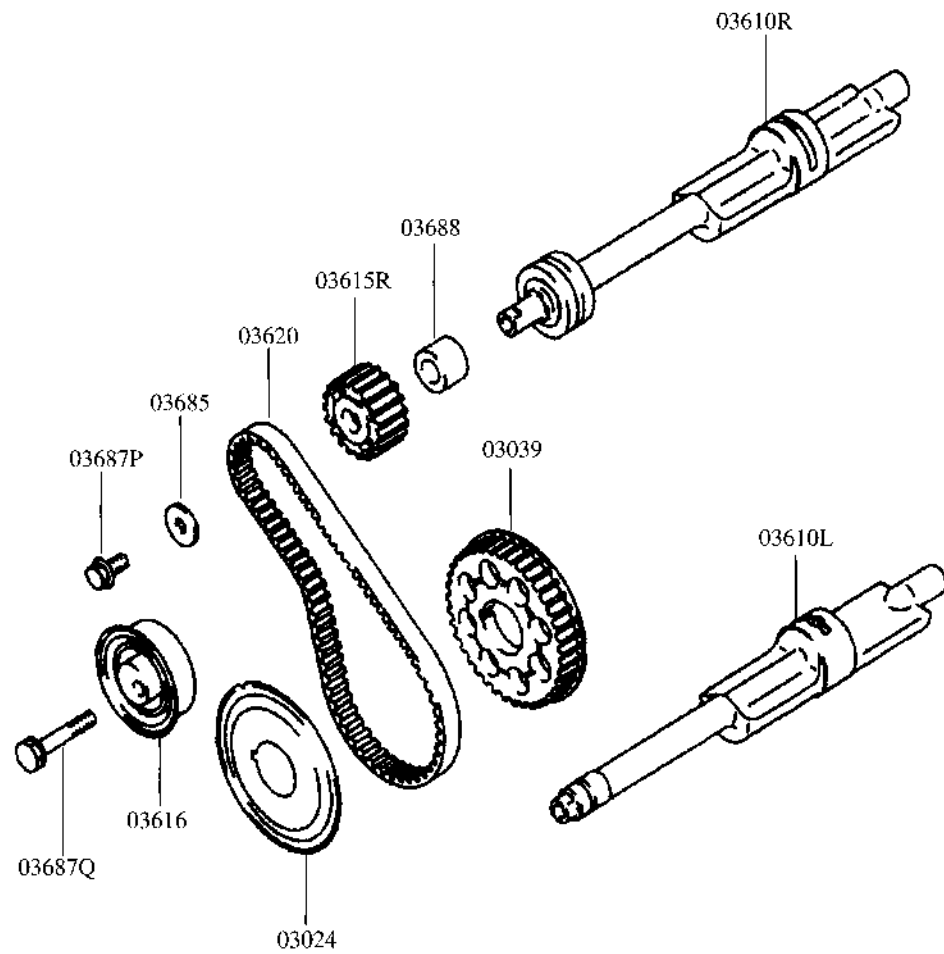

平衡轴 BALANCER

零件名称代号 FROM-UP-TO	零部件编号 PARTCODE	零部件名称 DESCRIPTION	用量/台 QTY	替换 REP	备注 REMARK
03024	SMD188501	曲轴齿带轮法兰 FLANGE,CRANKSHAFT SPROCKET	1		
03039	SMD187277	曲轴正时齿带轮 B SPROCKET,CRANKSHAFT "B"	1		
03610L	SMD103044	左平衡轴 SHAFT,BALANCER,LEFT	1		
03610R	SMD103045	右平衡轴 SHAFT,BALANCER,RIGHT	1		
03615R	SMD131282	平衡轴齿带轮 SPROCKET,BALANCER SHAFT	1		
03616	SMD115976	正时齿带 B 张紧器 TENSIONER, TIMING BELT"B"	1		
03620	SMD182295	正时齿带 B BELT, TIMING"B"	1		
03685	SMD145401	平衡轴齿带传动垫圈 WASHER,BALANCER BELT TRAIN	1		
03687P	SMD040758	平衡轴齿带传动螺栓 BOLT,BALANCER BELT TRAIN	1		
03687Q	MF244860	平衡轴齿带传动螺栓 BOLT,BALANCER BELT TRAIN	1		M8 × 45
03688	SMD040753	平衡轴齿带传动垫圈 SPACER,BALANCER BELT TRAIN	1		

11 - 320 机油压力开关 OIL SWITCH OR GAUGE UNIT

2

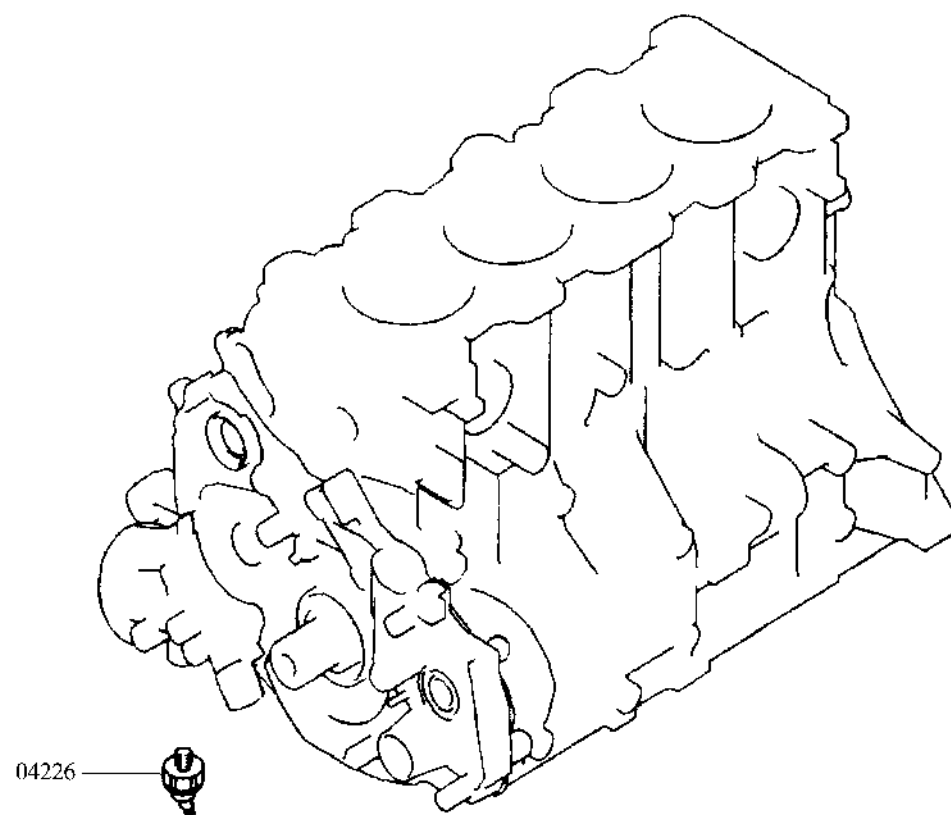

机油压力开关 OIL SWITCH OR GAUGE UNIT

零件名称代号 FROM-UP-TO	零部件编号 PARTCODE	零部件名称 DESCRIPTION	用量 / 台 QTY	替换 REP	备注 REMARK
04226	SMD138994	机油压力开关组件 SWITCH,ASSY OIL PRESSURE	1		

12 - 110 机油泵与机油滤清器 OIL PUMP & FELTER

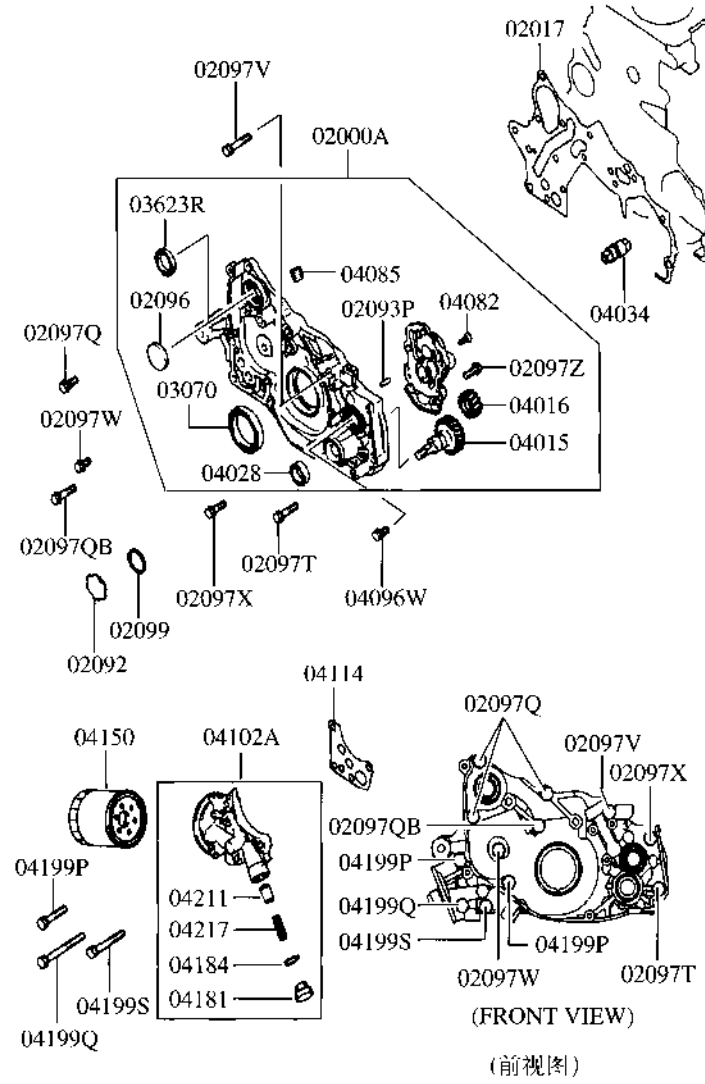

机油泵与机油滤清器 OIL PUMP & FELTER

零件名称代号 FROM-UP-TO	零部件编号 PARTCODE	零部件名称 DESCRIPTION	用量 / 台 QTY	替换 REP	备注 REMARK
02000A	SMD327450	机油泵壳体组件 CASE ASSY,OIL PUMP	1		
02017	SMD187905	前盖垫 GASKET,FRONT CASE	1		
02092	SMD125376	塞盖 PLUG CAP	1		
02093P	MF472403	定位销 PIN,DOWEL	2		定位 $\phi 6 \times 14$
02097Q	MF140225	带垫螺栓 BOLT,WASHER ASSEMBLED	2		法兰 M8 \times 20
02097QB	MF241254	带垫螺栓 BOLT,WASHER ASSEMBLED	1		带垫 M8 \times 22
02097T	MF140230	法兰螺栓 BOLT,FLANGE	1		法兰 M8 \times 32
02097V	MF140233	法兰螺栓 BOLT,FLANGE	1		法兰 M8 \times 40
02097W	MF140753	法兰螺栓 BOLT,FLANGE	1		法兰 M8 \times 16
02097X	MF140227	法兰螺栓 BOLT,FLANGE	1		法兰 M8 \times 25
02097Z	MF140025	法兰螺栓 BOLT,FLANGE	4		法兰 M8 \times 20
02099	SMD041021	O 型环 O-RING	1		$\Phi 26.2$
03070	SMD343563	油封 OIL SEAL	1		
03623R	SMD343565	右平衡轴前油封 OIL SEAL,BALANCER SHAFT,FR RH	1		
04015	SMD174581	机油泵驱动齿轮 GEAR,OIL PUMP DRIVE	1		
04016	SMD174582	机油泵从动齿轮 GEAR,OIL PUMP DRIVEN	1		
04028	SMD365697	油封 OIL SEAL	1		
04082	SMD141302	机制螺钉 SCREW MACHINE	1		
04085	SMD145018	锥形塞 PLUG TAPER	1		
04096W	SMD040758	法兰螺栓 BOLT,FLANGE	1		法兰 M8 \times 16
04102A	SMD189752	机油滤清器支架 BRACKET,OIL FILTER	1		
04114	SMD185528	机油滤清器支架垫 GASKET,OIL FILTER BRACKET	1		

机油泵与机油滤清器 OIL PUMP & FELTER

零件名称代号 FROM-UP-TO	零部件编号 PARTCODE	零部件名称 DESCRIPTION	用量 / 台 QTY	替换 REP	备注 REMARK
04150	SMD360935	机油滤清器组件 FILTER ASSY,OIL	1		
04181	SMD001404	螺塞 PLUG	1		M18
04184	SMD000312	垫片 GASKET	1		
04199P	MF241261	带垫螺栓 BOLT, WASHER ASSEMBLED	2		带垫 M8 × 40
04199Q	MF241268	带垫螺栓 BOLT, WASHER ASSEMBLED	1		带垫 M8 × 75
04199S	MF241264	带垫螺栓 BOLT, WASHER ASSEMBLED	1		带垫 M8 × 55
04211	SMD001402	泄压塞 PLUNGER,RELIEF	1		
04217	SMD050299	泄压弹簧 SPRING,RELIEF	1		

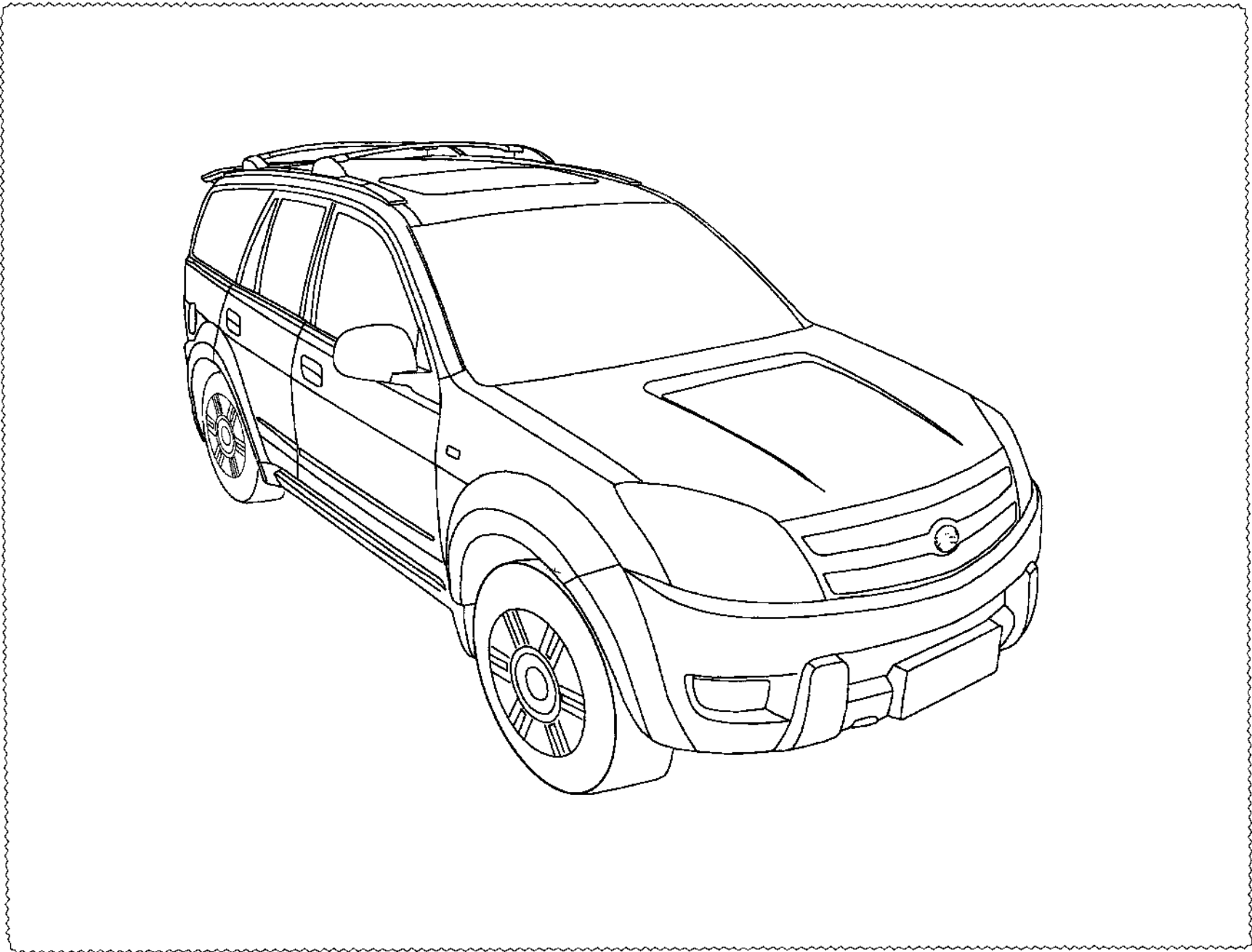

13-550 燃油喷射器及节气门体 INJECTOR & THROTTLE BODY

8

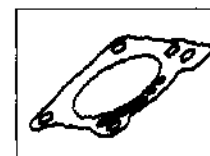
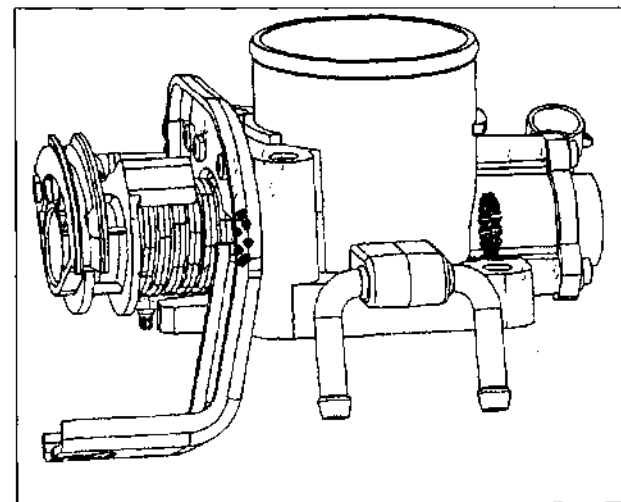
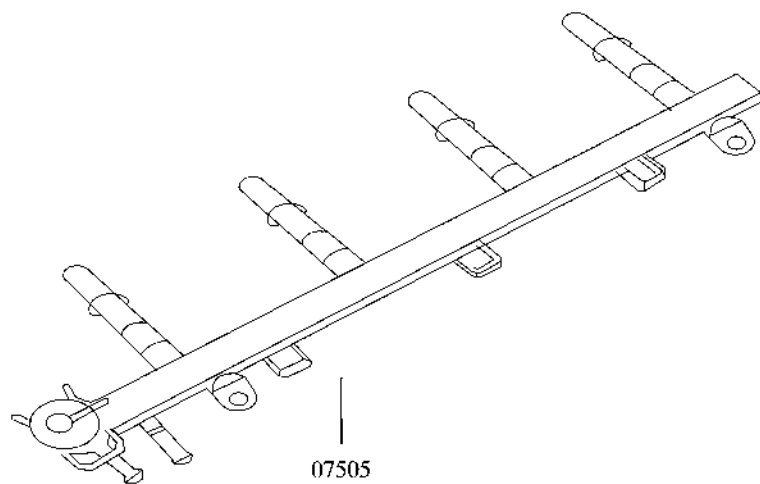

燃油喷射器及节气门体 INJECTOR & THROTTLE BODY

零件名称代号 FROM-UP-TO	零部件编号 PARTCODE	零部件名称 DESCRIPTION	用量 / 台 QTY	替换 REP	备注 REMARK
07505	SMW250271	燃油分配管总成 PIPE ASSY,FUEL DELIVERY	1		
07700A	SMW250123	节气门本体组件 THROTTLE BODY ASSY	1		
07710	SMW250189	节气门本体垫 GASKET,THROTTLE BODY	1		

14-110 水泵 WATER PUMP

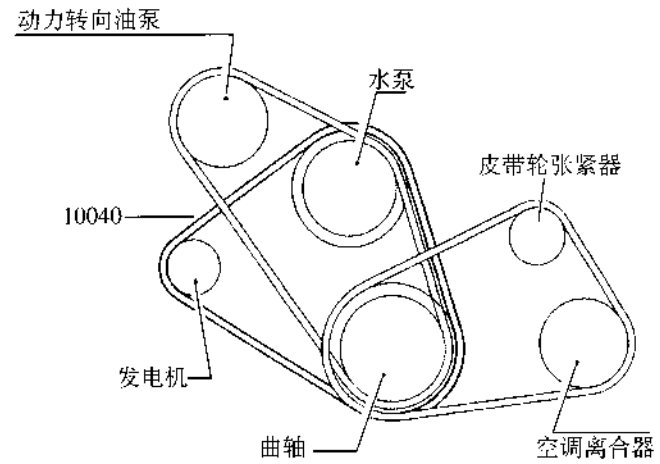
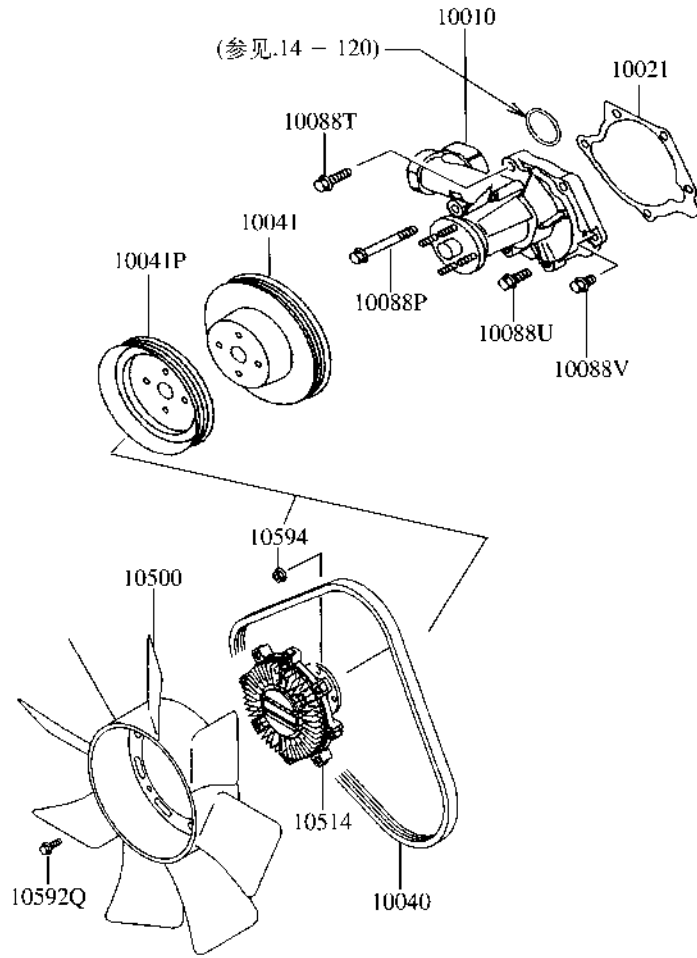

水泵 WATER PUMP

零件名称代号 FROM-UP-TO	零部件编号 PARTCODE	零部件名称 DESCRIPTION	用量 / 台 QTY	替换 REP	备注 REMARK
10010	SMD303389	水泵组件 PUMP ASSY,WATER	1		
10021	SMD315465	水泵垫 GASKET,WATER PUMP	1		
10040	SMD186125	V 型皮带 V-RIBBED BELT	1		L=985
10041	SMD312172	水泵皮带轮 PULLEY,WATER PUMP	1		带筋(1)
10041P	SMD312173	水泵及动力转向泵皮带轮 PULLEY,WATER PUMP,P/S	1		带筋(1)
10088P	MF140238	法兰螺栓 BOLT,FLANGE	1		M8 × 65
10088T	MF140028	法兰螺栓 BOLT,FLANGE	1		M8 × 28
10088U	MF140026	法兰螺栓 BOLT,FLANGE	2		M8 × 22
10088V	MF140022	法兰螺栓 BOLT,FLANGE	1		M8 × 14
10500	SMD361312	冷却风扇 FAN,COOLING	1		
10514	SMD361311	风扇离合器 CLUTCH,FAN	1		
10592Q	MF140210	法兰螺栓 BOLT,FLANGE	4		
10594	MF434103	法兰螺母 NUT,FLANGE	4		M6

14 - 120 水管及节温器 WATER PIPE & THERMOSTAT

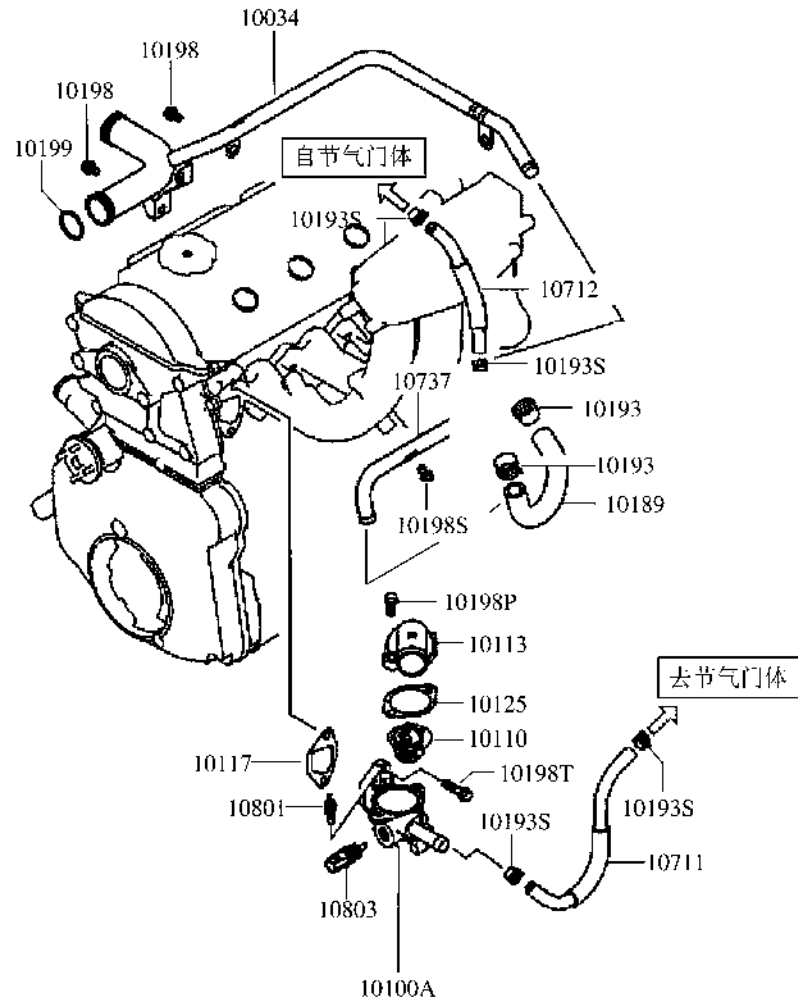

水管及节温器 WATER PIPE & THERMOSTAT

零件名称代号 FROM-UP-TO	零部件编号 PARTCODE	零部件名称 DESCRIPTION	用量/台 QTY	替换 REP	备注 REMARK
10034	SMW250513	进水管组件 PIPE, WATER PUMP INLET	1		
10100A	SMW250238	节温器壳组件 CASE ASSY, THERMOSTAT	1		
10110	SMD313946	节温器 THERMOSTAT KIT	1		
10113	SMD159638	出水接口 FITTING, WATER OUTLET HOSE	1		
10117	SMD323978	节温器壳体垫 GASKET, THERMOSTAT CASE	1		
10125	SMD184011	节温器水管接头垫 GASKET, THERMOSTAT WATER HOSE FITTING	1		
10198S	SMF140056	加热管螺栓 BOLT, HEATER LINE	1		法兰 M10 × 16
10189	SMW250261	冷却水软管 HOSE, COOLING WATER LINE	1		
10193	SMS660256	冷却水管夹 CLIP, COOLING WATER LINE	2		Φ 21.7
10193S	SMS660240	冷却水管夹 CLIP, COOLING WATER LINE	4		Φ 13.1
10198	SMF140021	冷却水管螺栓 BOLT, COOLING WATER LINE	3		法兰 M8 × 12
10198P	SMF241254	冷却水管螺栓 BOLT, COOLING WATER LINE	2		带垫 M8 × 22
10198T	SMF241259	冷却水管螺栓 BOLT, COOLING WATER LINE	2		带垫 M8 × 35
10199	SMD030764	冷却水管 O 型环 O - RING, COOLING WATER LINE	1		
10711	SMW250069	节气门体出水软管 HOSE, THROTTLE BODY WATER OUTLET	1		
10712	SMW250039	节气门体进水软管 HOSE, THROTTLE BODY WATER INLET	1		
10737	SMW250512	发动机加热器水管 PIPE, ENG HEATER WATER RET	1		
10801	SMD014929	锥形塞 PLUG, TAPER	1		
10803	SMW250119	水温传感器 SENSOR, WATER TEMPERATURE	1		

15 - 210 进气歧管 INLET MANIFOLD

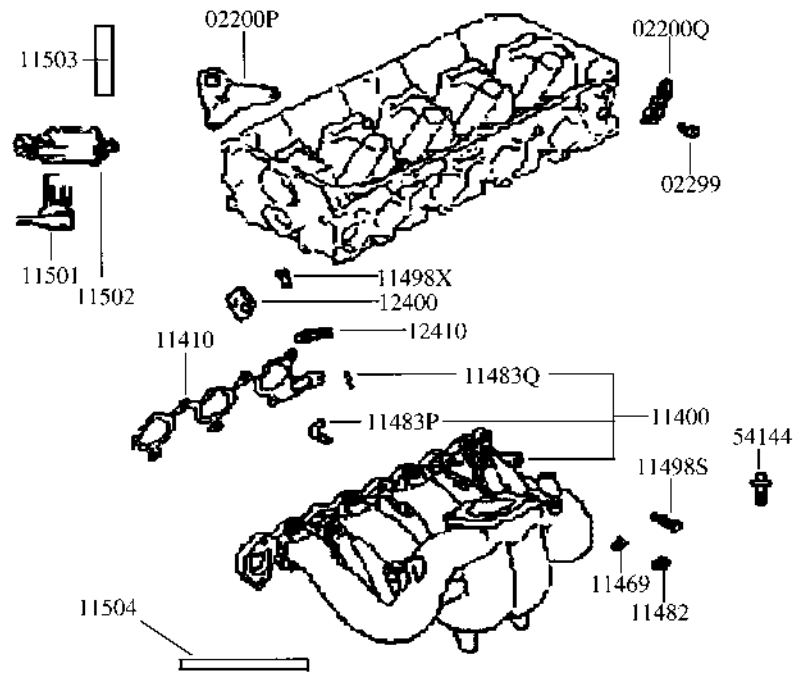

进气歧管 INLET MANIFOLD

零件名称代号 FROM-UP-TO	零部件编号 PARTCODE	零部件名称 DESCRIPTION	用量/台 QTY	替换 REP	备注 REMARK
02200P	SMD189802	发动机吊环 HANGER,ENGINE	1		
02200Q	SMD196781	发动机吊环 HANGER,ENGINE	1		
02299	MF241251	带垫螺栓 BOLT,WASHER ASSEMBLED	1		带垫 M8 × 16
11400	SMW250135	进气歧管 MANIFOLD,INTAKE	1		
11410	SMD193224	进气歧管垫 GASKET,MANIFOLD,INTAKE	1		
11469	MF450405	弹簧垫 WASHER ,SPRING	3		弹簧 8
11482	MF430151	螺母 NUT	3		锁紧 M8
11483P	SMD072820	接头 NIPPLE	2		8
11483Q	SMD108999	接头 NIPPLE	1		
11498S	MF241256	带垫螺栓 BOLT,WASHER ASSEMBLED	6		带垫 M8 × 28
12410	SMD183535	EGR 阀垫 GASKET,EGR	1		
11498X	SMF240051	带垫螺栓 BOLT,WASHER ASSEMBLED	2		带垫 M8 × 16
54144	MA140192	真空助力接头 FITTING	1		
12400	MD103510	盖 COVER	1		
11501	SMW250380	碳罐电磁阀支架 BRACKET, CANISTER SOLENOID	1		
11502	SMW250180	碳罐电磁阀 VALVE , CANISTER SOLENOID	1		
11503	SMW250429	蒸散软管 HOSE,VAPOR	1		
11504	SMW250241	真空软管组件 HOSE ASSY,VACUUM	1		

15-310 排气歧管 EXHAUST MANIFOLD

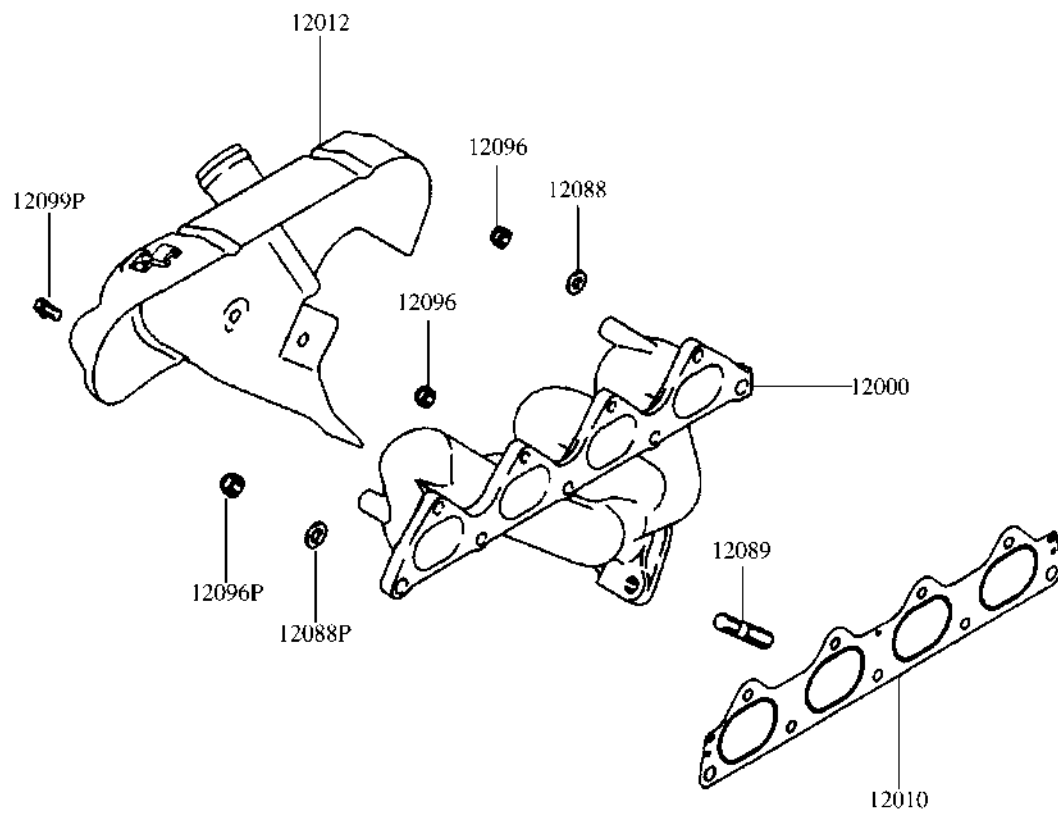

排气歧管 EXHAUST MANIFOLD

零件名称代号 FROM-UP-TO	零部件编号 PARTCODE	零部件名称 DESCRIPTION	用量 / 台 QTY	替换 REP	备注 REMARK
12000	SMR188193	排气歧管 MANIFOLD, EXHAUST	1		
12010	SMD181032	排气歧管垫 GASKET, MANIFOLD, EXHAUST	1		
12012	SMW250062	排气歧管罩 COVER, MANIFOLD, EXHAUST	1		
12088	SMD041192	平垫圈 WASHER, PLAIN	5		8
12088P	SMD050076	平垫圈 WASHER, PLAIN	2		10
12089	SMR497545	双头螺柱 STUD	2		M12 × 32
12096	SMR212302	法兰螺母 NUT, FLANGE	7		法兰 M8
12096P	SMR224500	法兰螺母 NUT, FLANGE	2		法兰 M10
12099P	SMD067956	法兰螺栓 BOLT, FLANGE	4		法兰 M8 × 12

15 - 710 排放控制 EMISSION CONTROL

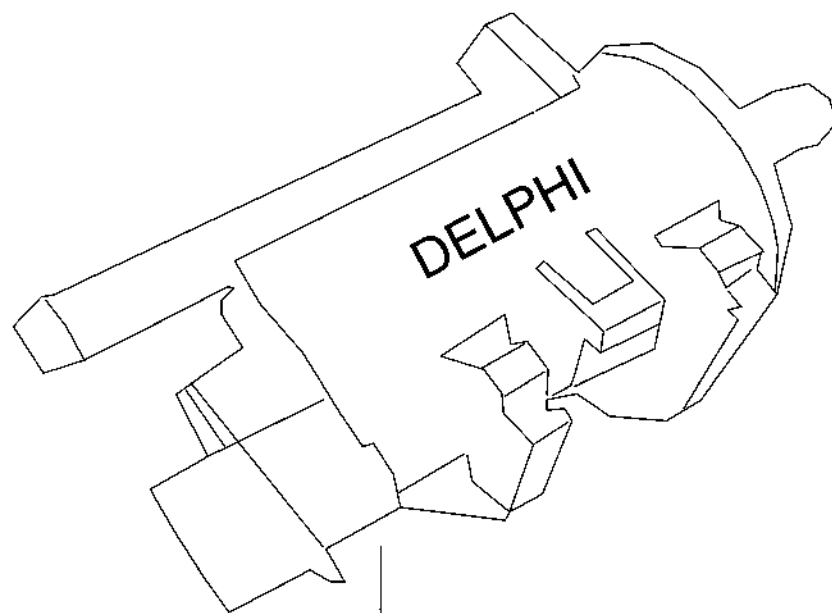

12400

排放控制 EMISSION CONTROL

零件名称代号 FROM-UP-TO	零部件编号 PARTCODE	零部件名称 DESCRIPTION	用量/台 QTY	替换 REP	备注 REMARK
12400	SMW250128	碳罐电磁阀 VALVE , CANISTER SOLENOID	1		

16-010 起动机 STARTER

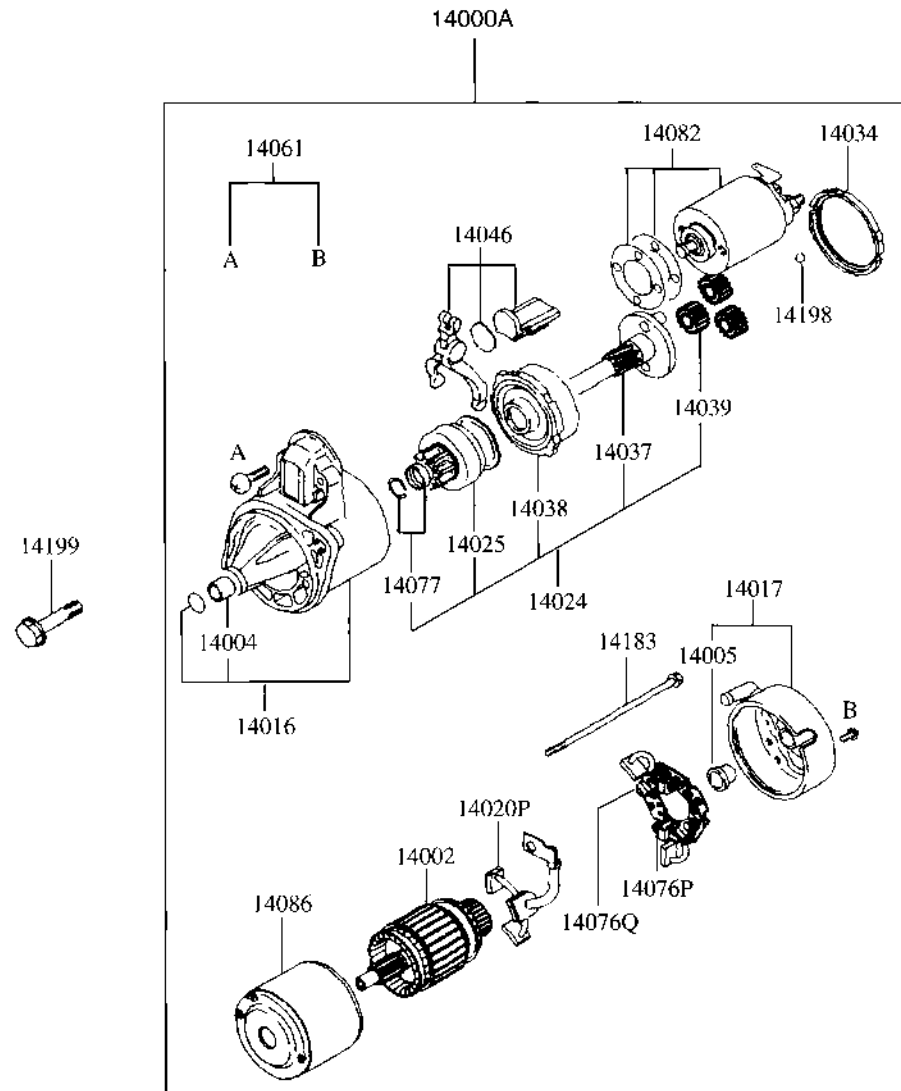

起动机 STARTER

零件名称代号 FROM-UP-TO	零部件编号 PARTCODE	零部件名称 DESCRIPTION	用量 / 台 QTY	替换 REP	备注 REMARK
14000A	SMD172860	起动机组件 STARTER ASSY	1		
14002	SMD618453	电枢 ARMATURE	1		
14004	SMD607892	前轴承 BEARING, FRONT	1		
14005	SMD618334	后轴承 BEARING, REAR	1		
14016	SMD618335	前支架组件 BRACKET ASSY, FRONT	1		
14017	SMD619701	后支架组件 BRACKET ASSY, REAR	1		
14020P	SMD619900	电刷连接器组件 CONN BRH ASSY	1		
14024	SMD618605	离合机构轴组件 SHAFT ASSY, CLUTCH SET	1		
14025	SMD611211	超速离合器 CLUTCH, OVERRUNNING	1		
14034	SMD611213	衬垫 PACKING	1		
14037	SMD611207	齿轮轴组件 SHAFT ASSY, GEAR	1		
14038	SMD618558	内齿轮组件 INTERNAL GEAR ASSY	1		
14039	SMD611210	齿轮组件 GEAR ASSY	3		
14046	SMD611223	杆组 LEVER SET	1		
14061	SMD607887	螺钉组 SCREW SET	1		
14076P	SMD607900	电刷弹簧 SPRING, BRUSH	2		
14076Q	SMD607901	电刷弹簧 SPRING, BRUSH	2		
14077	SMD611212	限位器组件 STOPPER ASSY	1		
14082	SMD618581	开关组件 SWITCH ASSY	1		
14086	SMD611215	定位架组件 YOKE ASSY	1		
14183	SMD611222	螺栓 BOLT, THROUGH	2		
14198	SMD611214	球 BALL	1		
14199	SMD108474	法兰螺栓 BOLT, FLANGE	2		M10 × 65

16 - 110 发电机 ALTERNATOR

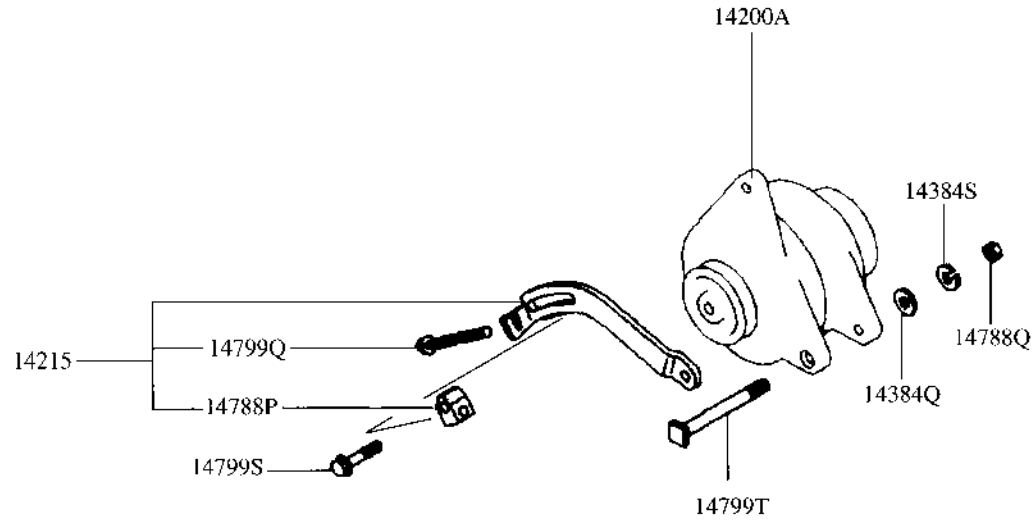

发电机 ALTERNATOR

零件名称代号 FROM-UP-TO	零部件编号 PARTCODE	零部件名称 DESCRIPTION	用量/台 QTY	替换 REP	备注 REMARK
14200A	SMD354804	发电机组件 ALTERNATOR ASSY	1		
14215	SMW250091	发电机支架组件 BRACKET ASSY	1		
14384Q	MF450005	平垫圈 WASHER, PLAIN	1		平 8
14384S	MF450405	弹簧垫圈 WASHER, SPRING	1		弹簧 8
14788P	SMD320269	调整螺母 NUT, ADJUST	1		调整 M9
14788Q	MF430121	螺母 NUT	1		M8
14799Q	SMD338980	法兰螺栓 BOLT, FLANGE	1		法兰 M8 × 65
14799S	MF140233	法兰螺栓 BOLT, FLANGE	1		法兰 M8 × 40
14799T	SMD162904	螺栓 BOLT	1		M8 × 118

16 - 220 火花塞、电缆及线圈 SPARK PLUG, CABLE & COIL

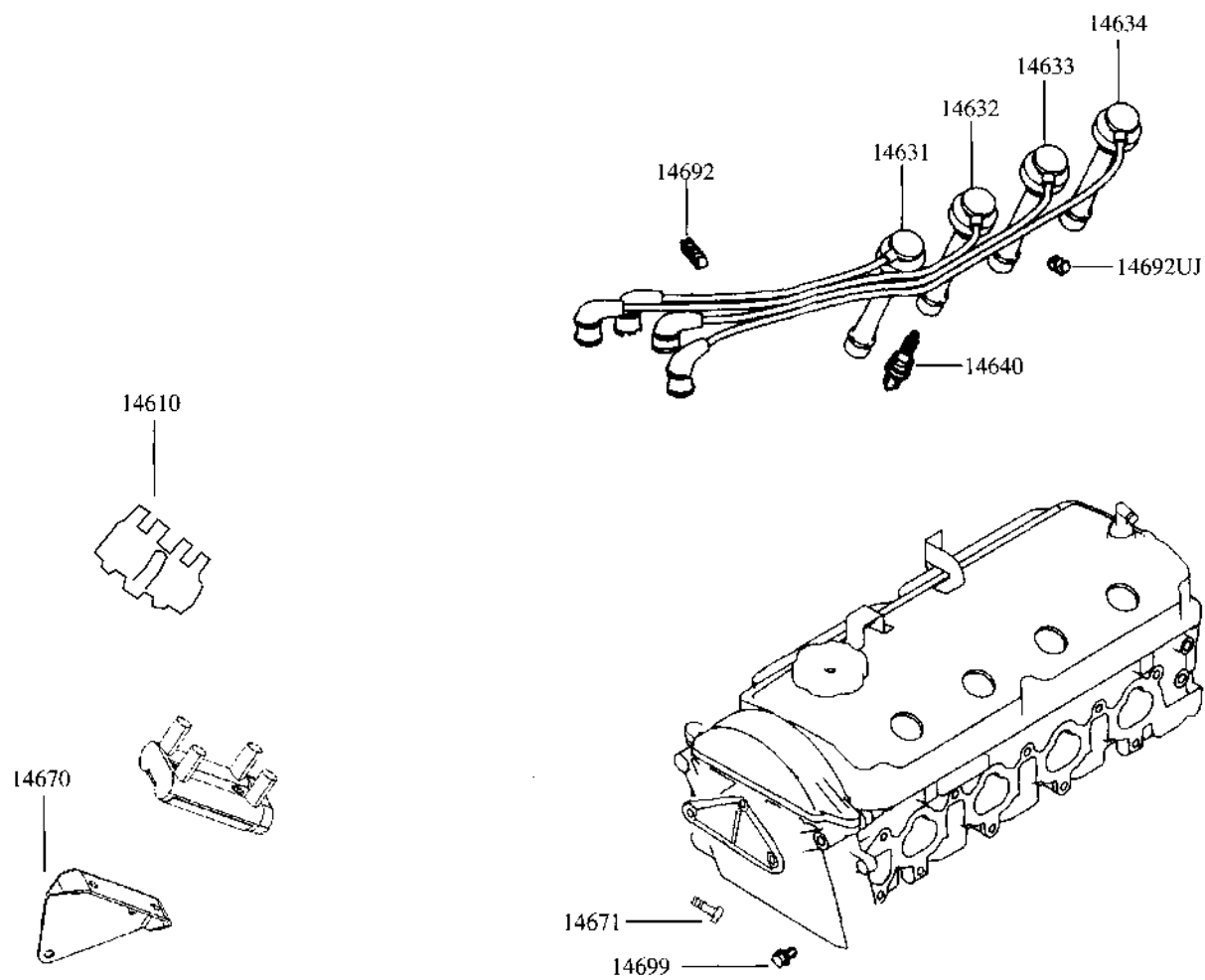

火花塞、电缆及线圈 SPARK PLUG, CABLE & COIL

零件名称代号 FROM-UP-TO	零部件编号 PARTCODE	零部件名称 DESCRIPTION	用量/台 QTY	替换 REP	备注 REMARK
14610	SMW250510	点火线圈组件 COIL ASSY, IGNITION	1		
14631	SMW250506	一缸火花塞电缆 CABLE, SPARK PLUG, NO.1	1		
14632	SMW250507	二缸火花塞电缆 CABLE, SPARK PLUG, NO.2	1		
14633	SMW250508	三缸火花塞电缆 CABLE, SPARK PLUG, NO.3	1		
14634	SMW250509	四缸火花塞电缆 CABLE, SPARK PLUG, NO.4	1		
14640	MS851387	火花塞组件 PLUG ASSY, SPARK	4		
14692	SMD120820	软管夹 CLAMP, HOSE	1		
14699	SMW250514	带垫螺栓 BOLT, FLANGE	2		法兰 M6 × 35
14670	SMW250515	点火线圈支架 BRACKET ASSY, IGNITION COIL	1		
14671	SMF140202	带垫螺栓 BOLT, FLANGE	3		

16-410 电子控制 ELECTRICAL CONTROL

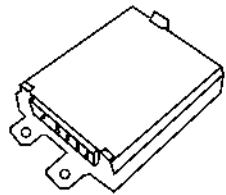

82522

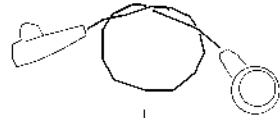

82522A

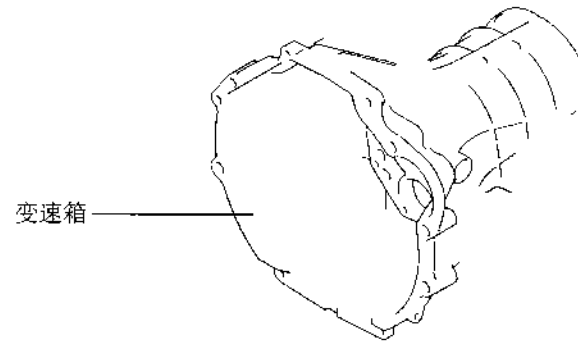

变速箱

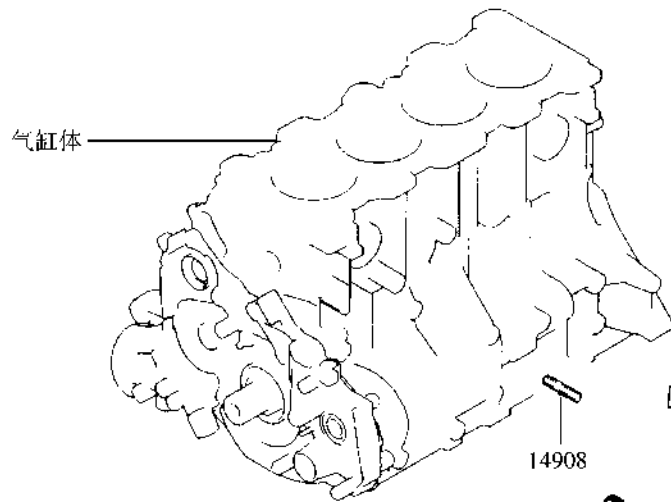

气缸体

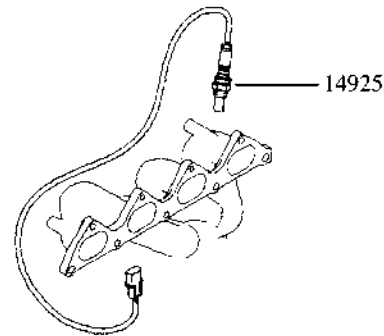

14925

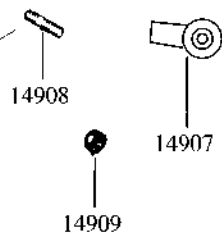

14908

14907

14909

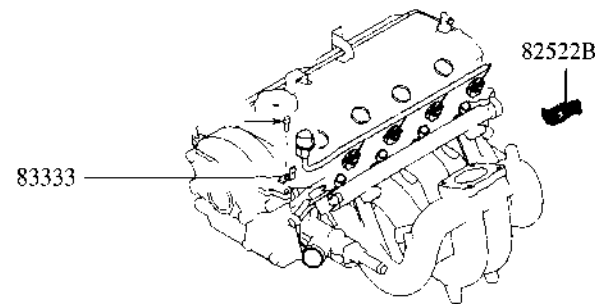

83333

82522B

电子控制 ELECTRICAL CONTROL

零件名称代号 FROM-UP-TO	零部件编号 PARTCODE	零部件名称 DESCRIPTION	用量/台 QTY	替换 REP	备注 REMARK
14925	SMW250480	氧传感器 SENSOR, ENG ELECTRIC CONTROL OXYGEN	1		
14907	SMW250130	爆震传感器 SENSOR, KNOCKING	1		
14908	SMW250200	爆震传感器螺栓 BOLT, KNOCKING SENSOR	1		
14909	SMF430151	爆震传感器螺母 NUT, KNOCKING SENSOR	1		
82522	SMW250504	电控单元 CONTROL UNIT,ENG ELECTRONIC	1		
82522A	SMW250129	曲轴角度传感器 CRANK ANGLE SENSOR	1		
82522B	SMW250118	进气压力及温度传感器 SENSOR,MAP&MAT	1		
83333	SMW250185	连接器支架 BRACKET,ENG CONTROL HARNESS CONNECTOR	1		

21-010 离合器及连接零部件 CLUTCH & CONNECTING PARTS

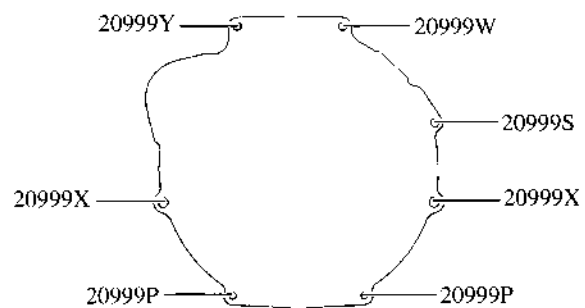
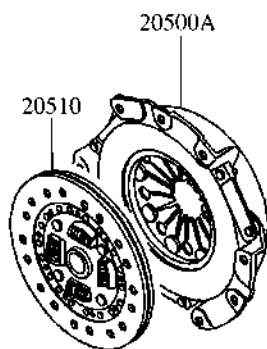
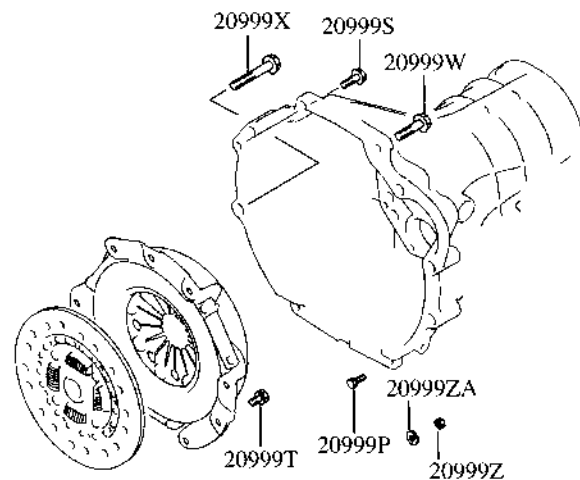
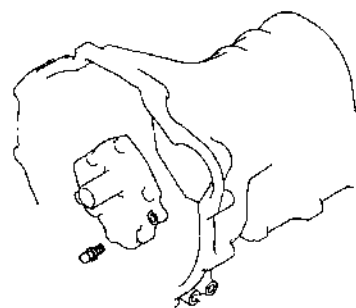

(REAR VIEW)
后视图

离合器 CLUTCH & CONNECTING PARTS

零件名称代号 FROM-UP-TO	零部件编号 PARTCODE	零部件名称 DESCRIPTION	用量/台 QTY	替换 REP	备注 REMARK
20500A	SMR331292	离合器壳组件 COVER ASSY,CLUTCH	1		
20510	SMR196312	摩擦片 4G64 S4 MPI DISC,CLUTCH	1		
20999P	MF140206	法兰螺栓(M6 × 18) 4G64 S4 MPI BOLT,FLANGE	2		
20999T	MF241251	带垫螺栓(M8 × 16) 4G64 S4 MPI BOLT, WASHER ASSY	6		
20999W	MF140266	法兰螺栓(M10 × 40) 4G64 S4 MPI BOLT,FLANGE	1		
20999X	MF140272	法兰螺栓(M10 × 70) 4G64 S4 MPI BOLT,FLANGE	3		
20999Y	MF140264	法兰螺栓(M10 × 35) 4G64 S4 MPI BOLT,FLANGE	1		
20999Z	MF430004	螺母(M6) 4G64 S4 MPI NUT	2		
20999ZA	MF450404	弹簧垫圈(6) 4G64 S4 MPI WASHER,SPRING	2		

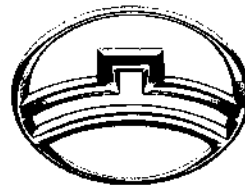

每天进步一点点

长城汽车股份有限公司

地址：河北省保定市朝阳南大街2266号
邮编：071000
销售热线：0312-2192888 传真：0312-2197600
服务热线：0312-2192885 传真：0312-2192936
网址：<http://www.gwm.com.cn>